

HC - HEATING/VAV COOLING:

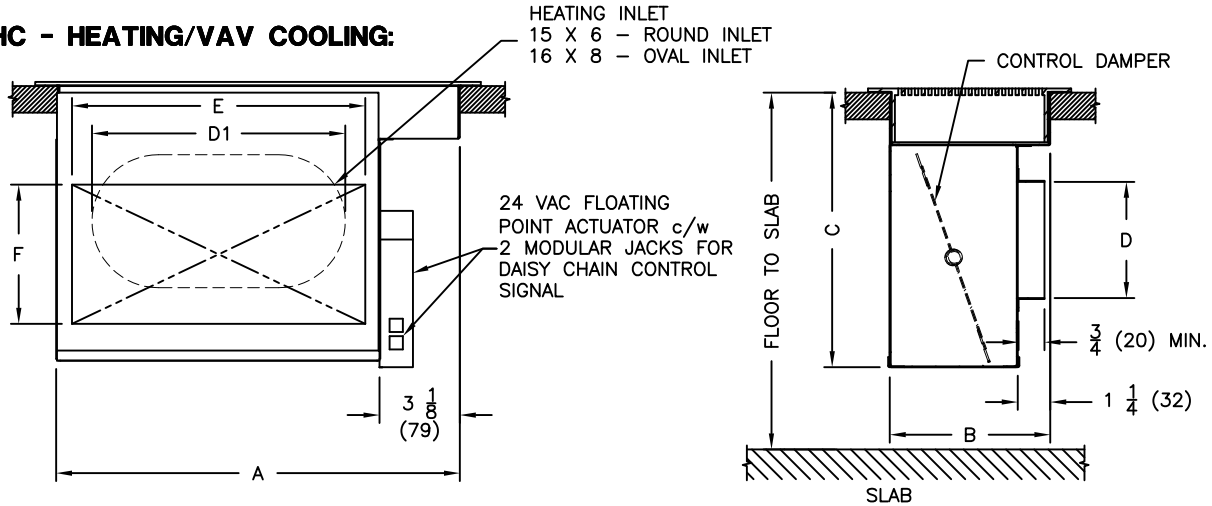

GRILLE SIZE	UNIT OVERALL			HEATING INLET		PLENUM INLET		GRILLE FACE FRAME		ROUGH OPENING
	A	B	C	D	D1	E	F	G	H	
15 X 6 (381 X 152)	15 1/8 (384)	6 1/8 (156)	10 3/8 (264)	5 7/8 (149)		11 (279)	5.5 (140)	16 5/8 (422)	7 5/8 (194)	15 1/4 X 6 1/4
16 X 8 (406 X 203)	16 1/8 (409)	8 1/8 (206)	11 1/4 (286)	5 (127)	9 1/2 (241)	12 (304)	5.5 (140)	17 5/8 (448)	9 5/8 (244)	16 1/4 X 8 1/4

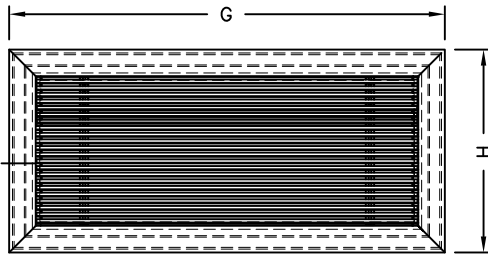

FASTENING DETAILS

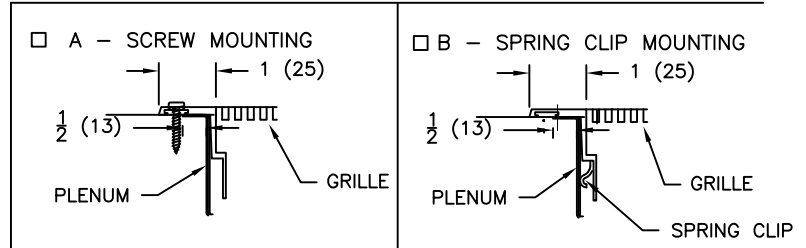

GRILLE:

- EXTRUDED ALUMINUM CONSTRUCTION
- PRESSED CORE WITH REINFORCING SUPPORT BARS
- 1" FACE FRAME

PLENUM:

- STEEL CONSTRUCTION
- BLACK FINISH
- ROUGH OPENING (SEE CHART)
- DROP IN INSTALLATION FROM ABOVE FLOOR

PLENUM/DAMPER:

- COMPLETE WITH 24 VAC ACTUATOR AND C25(25') PLENUM RATED CONTROL CABLE, BOTH ENDS TERMINATED W/MODULAR PLUGS

CORE OPTIONS:

- 1/4" (6) NARROW BAR SPACING
- 15A 0° DEFLECTION
- 16A 15° DEFLECTION
- 1/2" (13) WIDE BAR SPACING
- 15B 0° DEFLECTION
- 16B 15° DEFLECTION
- 25B 0° DEFLECTION
- 26B 15° DEFLECTION
- 27B 30° DEFLECTION
- 7/16" (11) PENCIL PROOF BAR SPACING
- 25C 0° DEFLECTION
- 26C 15° DEFLECTION
- 27C 30° DEFLECTION

GRILLE FINISH OPTIONS:

- B17 - BLACK
- B15 - ALUM. POWDER COAT
- #66 - BRUSHED AND CLEAR COAT (OPTIONAL FINISHES AVAILABLE)

ACCESSORIES OPTIONS:

- DV1

CONTROL CABLE OPTIONS:

- C25S (25') - ONE END TERMINATED WITH MODULAR PLUG OTHER END STRIPPED FOR TERMINAL BLOCK INSTALLATION

ALL METRIC DIMENSIONS () ARE SOFT CONVERTED. IMPERIAL DIMENSIONS ARE CONVERTED TO METRIC AND ROUNDED TO THE NEAREST MILLIMETER.

PROJECT:		PRICE®	
ENGINEER:			
CUSTOMER:		<i>DS</i>	LFG - HC LINEAR FLOOR GRILLE FOR 6", 8" DIA. INLET HC-HEATING/VAV COOLING
SUBMITTAL DATE:		236921	
SPEC. SYMBOL:		2010/05/25	

F-FAN SOURCED

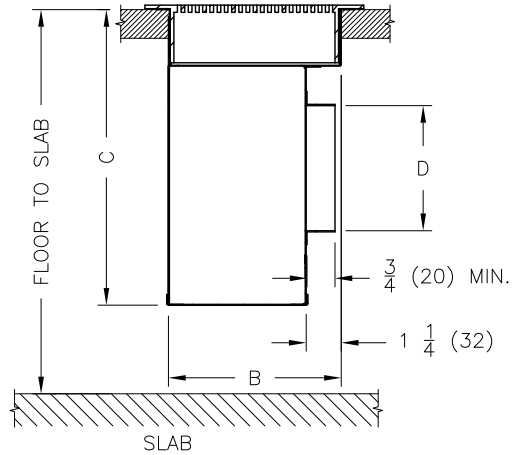
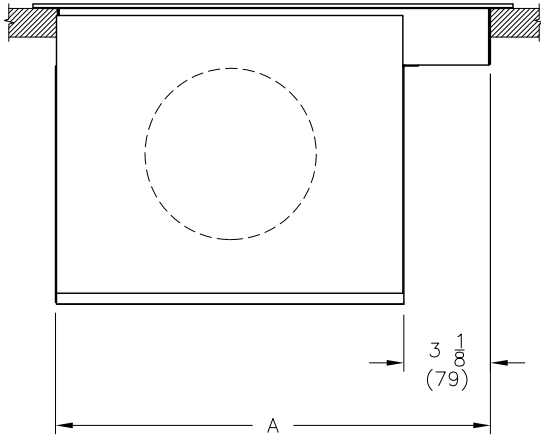

GRILLE SIZE	UNIT OVERALL			HEATING INLET	GRILLE FACE FRAME		ROUGH OPENING
	A	B	C	D	E	F	
15 X 6 (381 X 152)	15 1/8 (384)	6 1/8 (156)	10 3/8 (264)	5 7/8 (149)	16 5/8 (422)	7 5/8 (194)	15 1/4 X 6 1/4
16 X 8 (406 X 203)	16 1/8 (409)	8 1/8 (206)	11 1/4 (286)	7 7/8 (200)	17 5/8 (448)	9 5/8 (244)	16 1/4 X 8 1/4

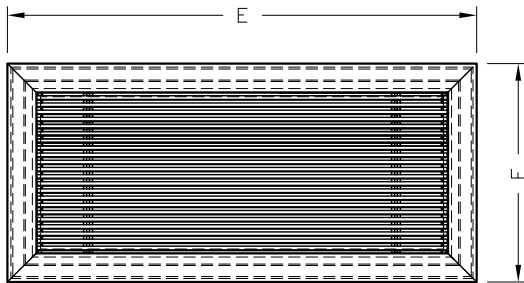

FASTENING DETAILS

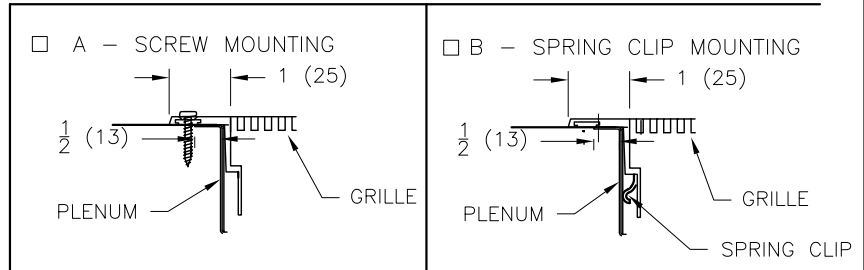

GRILLE:

- EXTRUDED ALUMINUM CONSTRUCTION
- PRESSED CORE WITH REINFORCING SUPPORT BARS
- 1" FACE FRAME

PLENUM:

- STEEL CONSTRUCTION
- BLACK FINISH
- ROUGH OPENING (SEE CHART) FOR DROP IN INSTALLATION FROM ABOVE FLOOR.

ACOUSTIC LINER:

- OPTIONAL 1/2" FIBREGLASS (1.5 LB. DENSITY MIN.) ACOUSTIC LINER

CORE OPTIONS:

- 1/4"(6)NARROW BAR SPACING**
 - 15A 0° DEFLECTION
 - 16A 15° DEFLECTION
- 1/2"(13)WIDE BAR SPACING**
 - 15B 0° DEFLECTION
 - 16B 15° DEFLECTION
 - 25B 0° DEFLECTION
 - 26B 15° DEFLECTION
 - 27B 30° DEFLECTION
- 7/16"(11)PENCIL PROOF BAR SPACING**
 - 25C 0° DEFLECTION
 - 26C 15° DEFLECTION
 - 27C 30° DEFLECTION

GRILLE FINISH OPTIONS:

- B17 - BLACK
- B15 - ALUM. POWDER COAT
- #66 - BRUSHED & CLEAR COAT (OPTIONAL FINISHES AVAILABLE)

ACCESSORIES OPTIONS:

- DV1

ALL METRIC DIMENSIONS () ARE SOFT CONVERTED. IMPERIAL DIMENSIONS ARE CONVERTED TO METRIC AND ROUNDED TO THE NEAREST MILLIMETER.

PROJECT:		PRICE®	
ENGINEER:			
CUSTOMER:		236922	LFG - F LINEAR FLOOR GRILLE FOR 6", 8" DIA. INLET F-FAN SOURCED
SUBMITTAL DATE:	SPEC. SYMBOL:	DEC 2008	

VC - VAV COOLING:

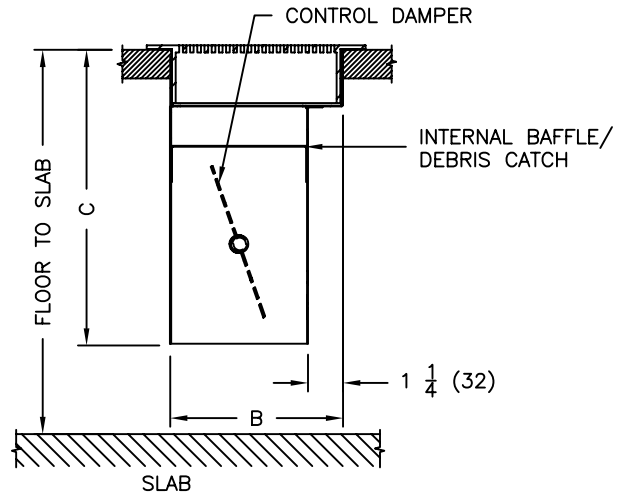
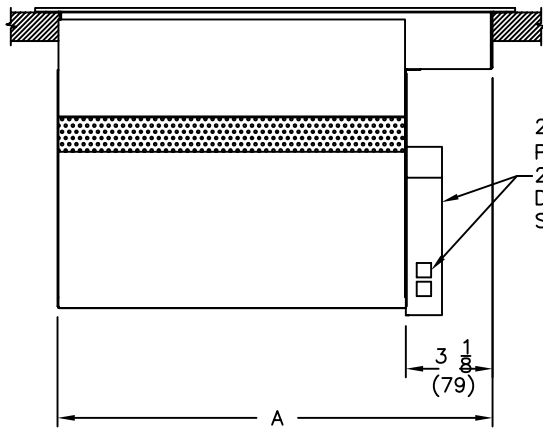

GRILLE SIZE	UNIT OVERALL			PLENUM INLET		GRILLE FACE FRAME		ROUGH OPENING
	A	B	C	D	E	F	G	
15 X 6 (381 X 152)	15 1/8 (384)	6 1/8 (156)	10 3/8 (264)	11 (279)	5.5 (140)	16 5/8 (422)	7 5/8 (194)	15 1/4 X 6 1/4
16 X 8 (406 X 203)	16 1/8 (409)	8 1/8 (206)	11 1/4 (286)	12 (304)	5.5 (140)	17 5/8 (448)	9 5/8 (244)	16 1/4 X 8 1/4

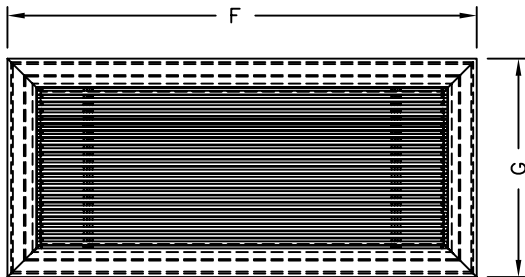

FASTENING DETAILS

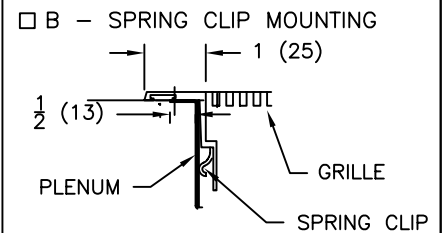
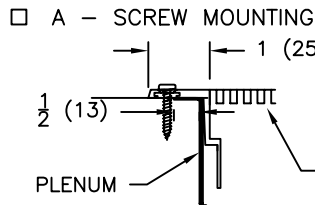

GRILLE:

- EXTRUDED ALUMINUM CONSTRUCTION
- PRESSED CORE WITH REINFORCING SUPPORT BARS
- 1" FACE FRAME

PLENUM:

- STEEL CONSTRUCTION
- BLACK FINISH
- ROUGH OPENING (SEE CHART)
DROP IN INSTALLATION FROM ABOVE FLOOR

PLENUM/DAMPER:

- COMPLETE WITH 24 VAC ACTUATOR AND C25(25') PLENUM RATED CONTROL CABLE, BOTH ENDS TERMINATED W/MODULAR PLUGS

CORE OPTIONS:

- 1/4" (6) NARROW BAR SPACING
- 15A 0° DEFLECTION
- 16A 15° DEFLECTION
- 1/2" (13) WIDE BAR SPACING
- 15B 0° DEFLECTION
- 16B 15° DEFLECTION
- 25B 0° DEFLECTION
- 26B 15° DEFLECTION
- 27B 30° DEFLECTION
- 7/16" (11) PENCIL PROOF BAR SPACING
- 25C 0° DEFLECTION
- 26C 15° DEFLECTION
- 27C 30° DEFLECTION

CONTROL CABLE OPTIONS:

- C25S (25') - ONE END TERMINATED WITH MODULAR PLUG OTHER END STRIPPED FOR TERMINAL BLOCK INSTALLATION

GRILLE FINISH OPTIONS:

- B17 - BLACK
- B15 - ALUM. POWDER COAT
- #66 - BRUSHED AND CLEAR COAT (OPTIONAL FINISHES AVAILABLE)

ACCESSORIES OPTIONS:

- DV1

ALL METRIC DIMENSIONS () ARE SOFT CONVERTED. IMPERIAL DIMENSIONS ARE CONVERTED TO METRIC AND ROUNDED TO THE NEAREST MILLIMETER.

PROJECT:		PRICE®	
ENGINEER:			LFG - VC LINEAR FLOOR GRILLE VC-VAV COOLING
CUSTOMER:			
SUBMITTAL DATE:	SPEC. SYMBOL:	APRIL 2006	

C-CONST. VOL. COOLING:

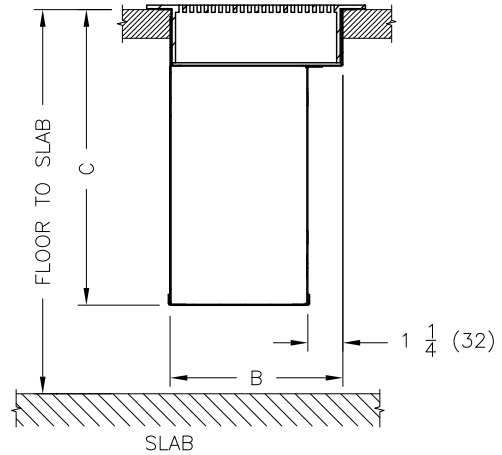
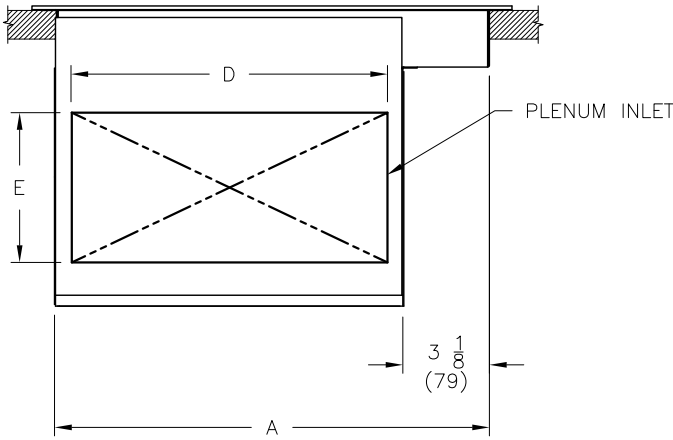

GRILLE SIZE	UNIT OVERALL			PLENUM INLET		GRILLE FACE FRAME		ROUGH OPENING
	A	B	C	D	E	F	G	
15 X 6 (381 X 152)	15 1/8 (384)	6 1/8 (156)	10 3/8 (264)	11 (279)	5.5 (140)	16 5/8 (422)	7 5/8 (194)	15 1/4 X 6 1/4
16 X 8 (406 X 203)	16 1/8 (409)	8 1/8 (206)	11 1/4 (286)	12 (304)	5.5 (140)	17 5/8 (448)	9 5/8 (244)	16 1/4 X 8 1/4

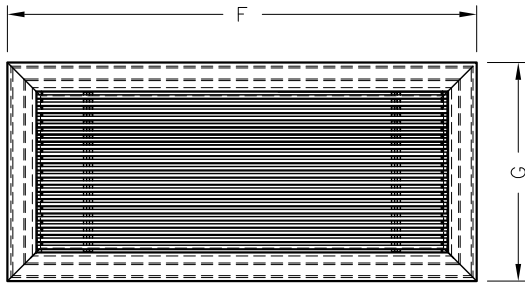

FASTENING DETAILS

A - SCREW MOUNTING

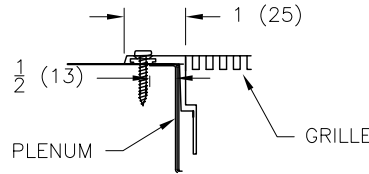

B - SPRING CLIP MOUNTING

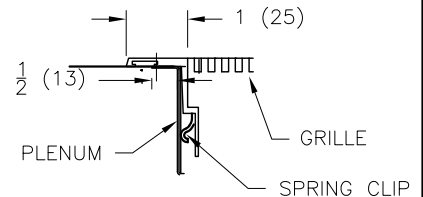

GRILLE:

- EXTRUDED ALUMINUM CONSTRUCTION
- PRESSED CORE WITH REINFORCING SUPPORT BARS
- 1" FACE FRAME

PLENUM:

- STEEL CONSTRUCTION
- BLACK FINISH
- ROUGH OPENING (SEE CHART)
FOR DROP IN INSTALLATION FROM ABOVE FLOOR.

ACOUSTIC LINER:

- OPTIONAL 1/2" FIBREGLASS (1.5 LB. DENSITY MIN.) ACOUSTIC LINER

CORE OPTIONS:

1/4"(6)NARROW BAR SPACING

- 15A 0° DEFLECTION
- 16A 15° DEFLECTION

1/2"(13)WIDE BAR SPACING

- 15B 0° DEFLECTION
- 16B 15° DEFLECTION
- 25B 0° DEFLECTION
- 26B 15° DEFLECTION
- 27B 30° DEFLECTION

7/16"(11)PENCIL PROOF BAR SPACING

- 25C 0° DEFLECTION
- 26C 15° DEFLECTION
- 27C 30° DEFLECTION

GRILLE FINISH OPTIONS:

- B17 - BLACK
- B15 - ALUM. POWDER COAT
- #66 - BRUSHED & CLEAR COAT
(OPTIONAL FINISHES AVAILABLE)

ACCESSORIES OPTIONS:

- DV1

ALL METRIC DIMENSIONS () ARE SOFT CONVERTED. IMPERIAL DIMENSIONS ARE CONVERTED TO METRIC AND ROUNDED TO THE NEAREST MILLIMETER.

PROJECT:

ENGINEER:

CUSTOMER:

SUBMITTAL DATE:

SPEC. SYMBOL:



DS

237703

DEC 2008

LFG - C

LINEAR FLOOR GRILLE
C-CONST. VOL. COOLING

LFGH

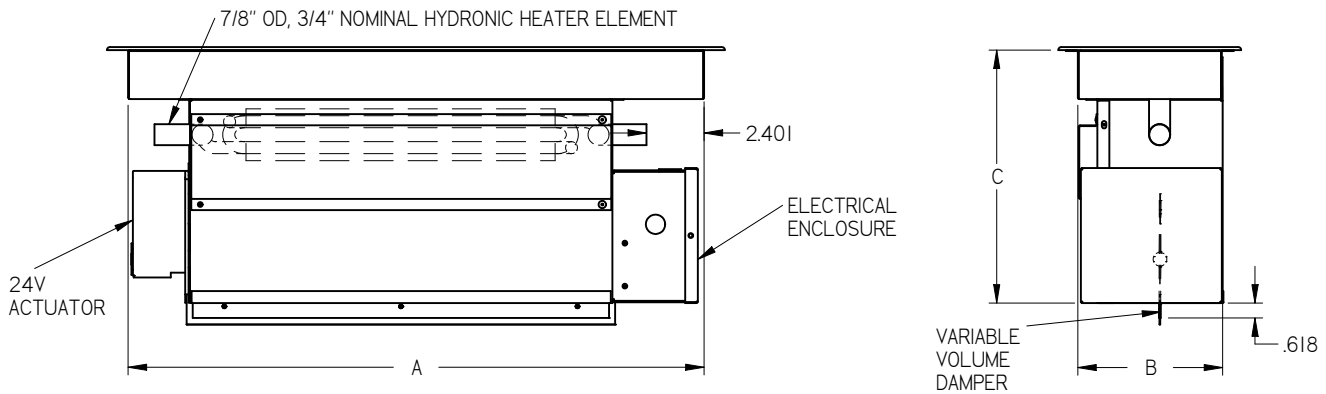

GRILLE	UNIT OVERALL			GRILLE FACE FRAME		ROUGH OPENING	AIRFLOW (CFM)
	A	B	C	F	G		
24 x 6 (610 x 152)	23 3/4 (603)	6 1/8 (156)	10 1/2 (267)	25 3/8 (645)	7 5/8 (194)	24 x 6 1/4 (610 x 159)	100-200
48 x 6 (1219 x 152)	47 3/4 (1213)	6 1/8 (156)	10 1/2 (267)	49 3/5 (1254)	7 5/8 (194)	48 x 6 1/4 (1219 x 159)	300-500

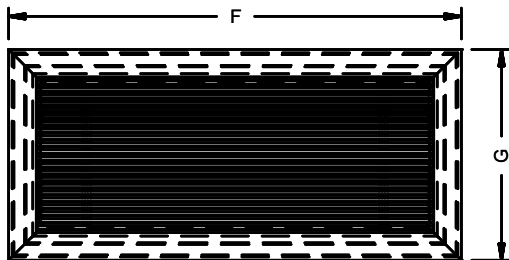

FASTENING DETAILS

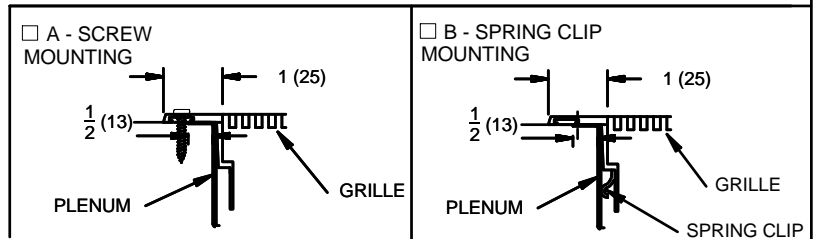

GRILLE:

- EXTRUDED ALUMINUM CONSTRUCTION
- PRESSED CORE WITH REINFORCING SUPPORT BARS
- 1" FACE FRAME

PLENUM:

- BLACK FINISH
- ROUGH OPENING (SEE CHART)
- FOR DROP IN INSTALLATION FROM ABOVE FLOOR

HEATER ELEMENT:

- 7/8" OD, 3/4" NOM. CONNECTION HOT WATER COIL
- 120/1/60 TRANSFORMER
- 240/1/60 TRANSFORMER

CONTROL TYPE:

- MASTER
- SLAVE (NO HOT WATER VALVE CONTROL)

CORE OPTIONS:

- 1/4"(6) NARROW BAR SPACING
- 15A 0° DEFLECTION
- 16A 15° DEFLECTION
- 1/2"(13) WIDE BAR SPACING
- 15B 0° DEFLECTION
- 16B 15° DEFLECTION
- 25B 0° DEFLECTION
- 26B 15° DEFLECTION
- 27B 30° DEFLECTION

7/16"(11) PENCIL PROOF BAR SPACING

- 25C 0° DEFLECTION
- 26C 15° DEFLECTION
- 27C 30° DEFLECTION

ACTUATOR:

- 24V FLOATING POINT - VAV
- NO DAMPER - CAV

GRILLE FINISH OPTIONS:

- B17 - BLACK
- B15 - ALUM. POWDER COAT
- #66 - BRUSHED & CLEAR COAT
- OPTIONAL FINISHES AVAILABLE

ACCESSORIES OPTIONS:

- DV1



ALL METRIC DIMENSIONS () ARE SOFT CONVERTED. IMPERIAL DIMENSIONS ARE CONVERTED TO METRIC AND ROUNDED TO THE NEAREST MILLIMETER.

PROJECT:		 DS LFGH LINEAR FLOOR GRILLE HYDRONIC ELEMENT 24x6, 48x6
ENGINEER:		
CUSTOMER:		
SUBMITTAL DATE:		
SPEC. SYMBOL:		246948
		2010/02/08

LFGH

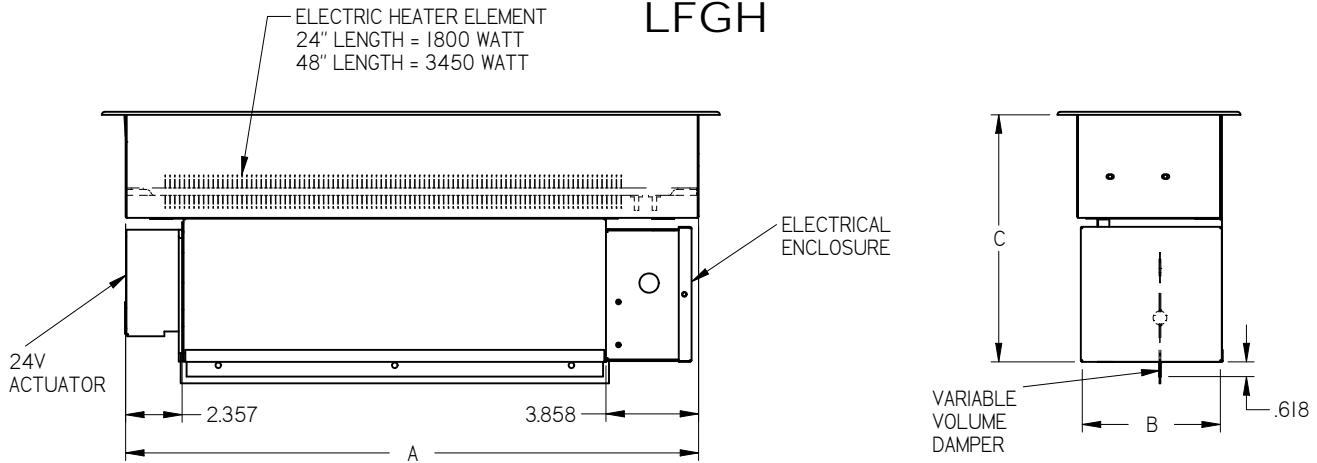

GRILLE	UNIT OVERALL			GRILLE FACE FRAME		ROUGH OPENING	AIRFLOW (CFM)
	A	B	C	F	G		
24 x 6 (610 x 152)	23 3/4 (603)	6 1/8 (156)	10 1/2 (267)	25 1/2 (648)	7 5/8 (194)	24 x 6 1/4 (610 x 159)	100-200
48 x 6 (1219 x 152)	47 3/4 (1213)	6 1/8 (156)	10 1/2 (267)	49 1/2 (1257)	7 5/8 (194)	48 x 6 1/4 (1219 x 159)	300-500

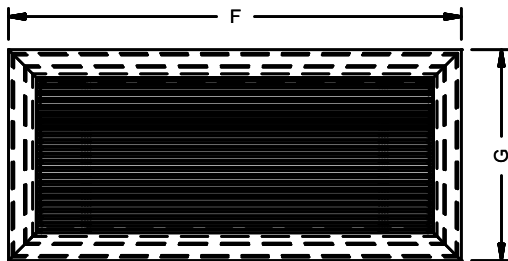

FASTENING DETAILS



GRILLE:

- EXTRUDED ALUMINUM CONSTRUCTION
- PRESSED CORE WITH REINFORCING SUPPORT BARS
- 1" FACE FRAME

PLENUM:

- BLACK FINISH
- ROUGH OPENING (SEE CHART)
- FOR DROP IN INSTALLATION FROM ABOVE FLOOR

HEATER ELEMENT:

- 120/1/60 ELECTRICAL (24" MODEL ONLY)
- 240/1/60 ELECTRICAL (24" OR 48" MODEL)
- FINNED STRIP HEATER; MULTIPLE ELEMENTS
- MAY BE SUPPLIED ON LONGER UNITS
- TRANSFORMER INCLUDED

CORE OPTIONS:

- 1/4"(6) NARROW BAR SPACING
- 15A 0° DEFLECTION
- 16A 15° DEFLECTION

1/2"(13) WIDE BAR SPACING

- 15B 0° DEFLECTION
- 16B 15° DEFLECTION
- 25B 0° DEFLECTION
- 26B 15° DEFLECTION
- 27B 30° DEFLECTION

7/16"(11) PENCIL PROOF BAR SPACING

- 25C 0° DEFLECTION
- 26C 15° DEFLECTION
- 27C 30° DEFLECTION

ACTUATOR:

- 24V FLOATING POINT - VAV
- NO DAMPER - CAV

GRILLE FINISH OPTIONS:

- B17 - BLACK
- B15 - ALUM. POWDER COAT
- #66 - BRUSHED & CLEAR COAT
- OPTIONAL FINISHES AVAILABLE

ACCESSORIES OPTIONS:

- DV1



ALL METRIC DIMENSIONS () ARE SOFT CONVERTED. IMPERIAL DIMENSIONS ARE CONVERTED TO METRIC AND ROUNDED TO THE NEAREST MILLIMETER.

PROJECT:		 DS 246196 2010/02/08	LFGH LINEAR FLOOR GRILLE ELECTRIC HEAT 24x6, 48x6
ENGINEER:			
CUSTOMER:			
SUBMITTAL DATE:	SPEC. SYMBOL:		

LFGH - RC

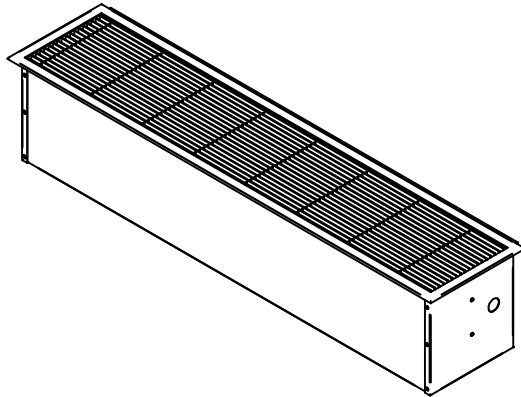
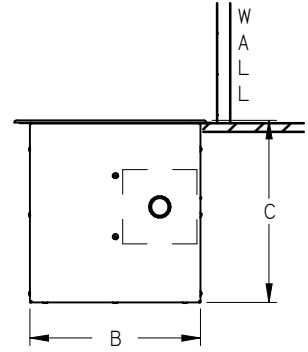
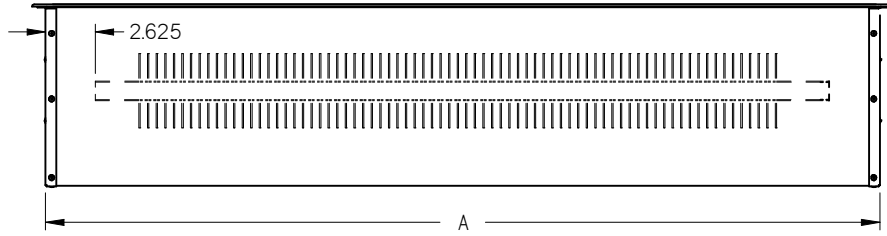

NOM. SIZE	UNIT OVERALL			GRILLE FACE FRAME		ROUGH OPENING
	A	B	C	F	G	
24 x 10	23 3/4 (603)	9 3/4 (248)	10 1/2 (267)	25 3/8 (645)	11 1/4 (286)	24 x 10
48 x 10	47 3/4 (1213)	9 3/4 (248)	10 1/2 (267)	49 3/8 (1254)	11 1/4 (286)	48 x 10
72 x 10	71 3/4 (1822)	9 3/4 (248)	10 1/2 (267)	73 3/8 (1864)	11 1/4 (286)	72 x 10
96 x 10	95 3/4 (2432)	9 3/4 (248)	10 1/2 (267)	97 3/8 (2473)	11 1/4 (286)	96 x 10

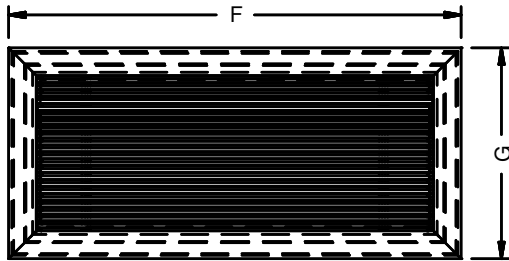

FASTENING DETAILS

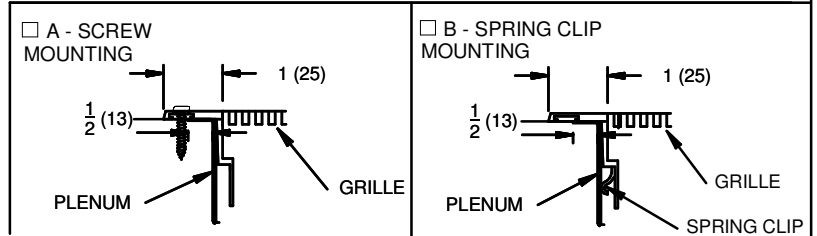

GRILLE:

- EXTRUDED ALUMINUM CONSTRUCTION
- PRESSED CORE WITH REINFORCING SUPPORT BARS
- 1" FACE FRAME

PLENUM:

- BLACK FINISH
- ROUGH OPENING (SEE CHART)
FOR DROP IN INSTALLATION FROM ABOVE FLOOR
- 1/2" INTERNAL FIBRE-FREE INSULATION

HEATER ELEMENT:

- 1" NOM. (1.125" OD) COPPER TUBE
- 4.25" x 4.25" ALUMINUM FINNS

CORE OPTIONS:

- 1/4"(6) NARROW BAR SPACING
- 15A 0° DEFLECTION
- 16A 15° DEFLECTION
- 1/2"(13) WIDE BAR SPACING
- 15B 0° DEFLECTION
- 16B 15° DEFLECTION
- 25B 0° DEFLECTION
- 26B 15° DEFLECTION
- 27B 30° DEFLECTION
- 7/16"(11) PENCIL PROOF BAR SPACING
- 25C 0° DEFLECTION
- 26C 15° DEFLECTION
- 27C 30° DEFLECTION

GRILLE FINISH OPTIONS:

- B17 - BLACK
- B15 - ALUM. POWDER COAT
- #66 - BRUSHED & CLEAR COAT
- SPL - OPTIONAL FINISHES AVAILABLE
- AC - ANODIZED CLEAR
- ALB - ANODIZED LIGHT BRONZE
- AMB - ANODIZED MEDIUM BRONZE
- ADB - ANODIZED DARK BRONZE
- AB - ANODIZED BLACK
- ASPL - ANODIZED SPECIAL COLOR

ACCESSORIES OPTIONS:

- DV1

ALL METRIC DIMENSIONS () ARE SOFT CONVERTED. IMPERIAL DIMENSIONS ARE CONVERTED TO METRIC AND ROUNDED TO THE NEAREST MILLIMETER.

PROJECT:		 DS 253221 2010/09/28	LFGH-RC LINEAR FLOOR GRILLE HYDRONIC HEAT RECIRCULATION
ENGINEER:			
CUSTOMER:			
SUBMITTAL DATE:	SPEC. SYMBOL:		

LFGH - RC

LFGH-RC CONTINUOUS:

LENGTHS > 96" ARE SUPPLIED IN SECTIONS TO BE ASSEMBLED ON-SITE.

BAR GRILLE SUPPLIED IN MULTIPLE SECTIONS

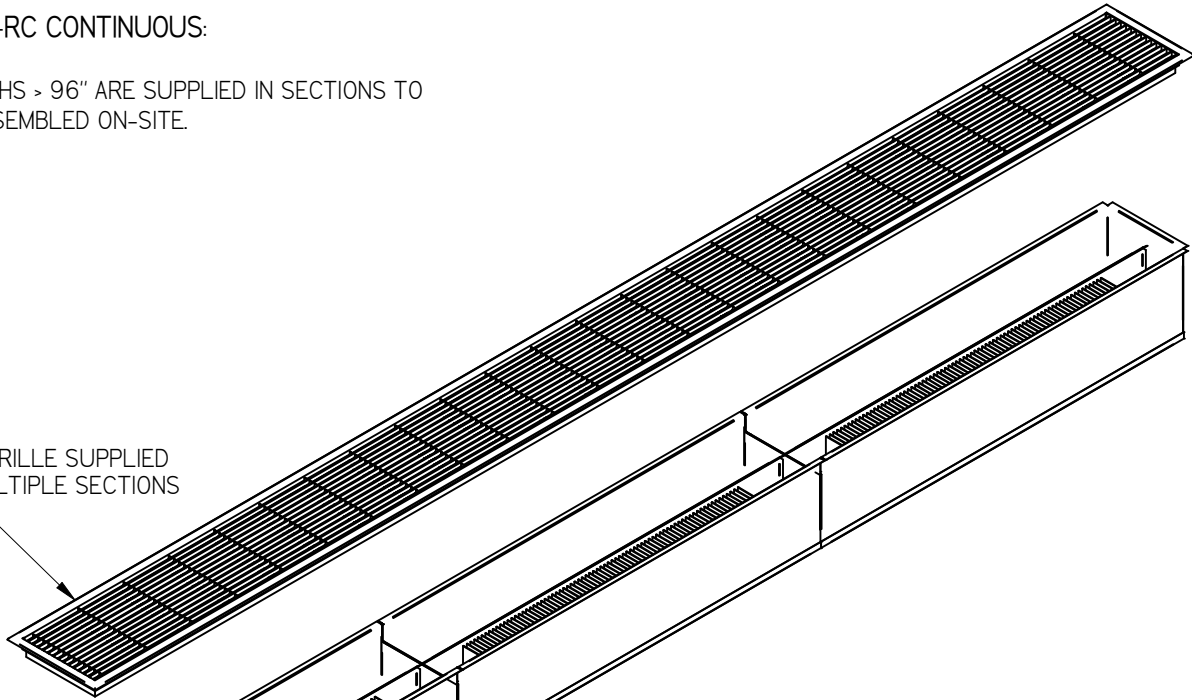

PLENUM SUPPLIED IN MULTIPLE SECTIONS TO MAKE UP LENGTH REQUIRED. UNITS FLANGED TOGETHER FOR FIELD CONNECTION.

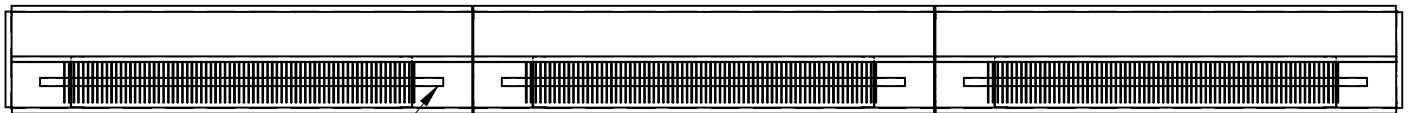

* FIELD CONNECTION BETWEEN HEATERS IS REQUIRED

ALL METRIC DIMENSIONS () ARE SOFT CONVERTED. IMPERIAL DIMENSIONS ARE CONVERTED TO METRIC AND ROUNDED TO THE NEAREST MILLIMETER.

PROJECT:		PRICE
ENGINEER:		
CUSTOMER:		DS
SUBMITTAL DATE:		253221
SPEC. SYMBOL:		2010/09/28
		LFGH-RC LINEAR FLOOR GRILLE HYDRONIC HEAT RECIRCULATION

LFGH - RCV

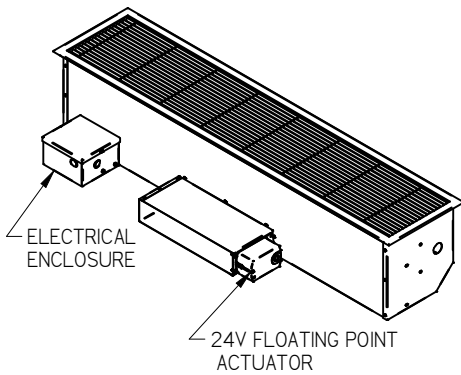
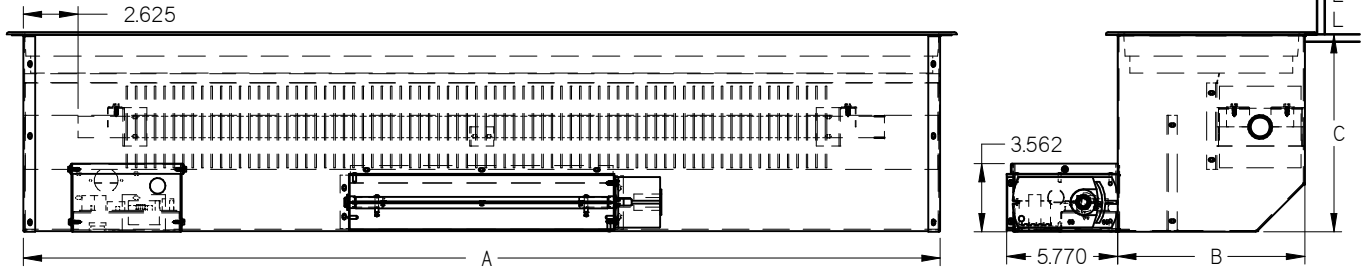

NOM. SIZE	UNIT OVERALL			GRILLE FACE FRAME		ROUGH OPENING	AIRFLOW (CFM)
	A	B	C	F	G		
24 x 10	23 3/4 (603)	9 3/4 (248)	10 1/2 (267)	25 3/8 (645)	11 1/4 (286)	24 x 10	100 - 140
48 x 10	47 3/4 (1213)	9 3/4 (248)	10 1/2 (267)	49 3/8 (1254)	11 1/4 (286)	48 x 10	200 - 280
72 x 10	71 3/4 (1822)	9 3/4 (248)	10 1/2 (267)	73 3/8 (1864)	11 1/4 (286)	72 x 10	300 - 420
96 x 10	95 3/4 (2432)	9 3/4 (248)	10 1/2 (267)	97 3/8 (2473)	11 1/4 (286)	96 x 10	400 - 560

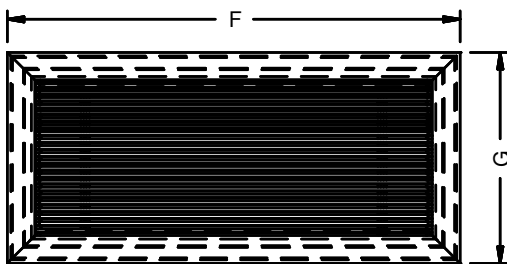

FASTENING DETAILS

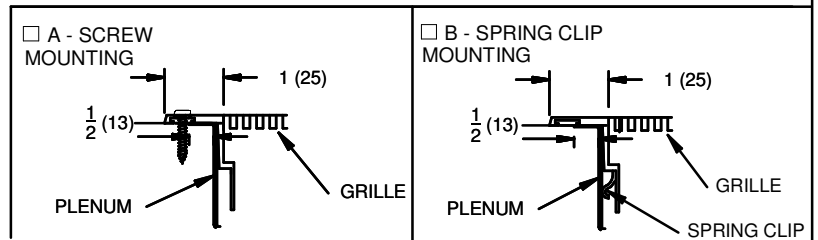

GRILLE:

- EXTRUDED ALUMINUM CONSTRUCTION
- PRESSED CORE WITH REINFORCING SUPPORT BARS
- 1" FACE FRAME

PLENUM:

- BLACK FINISH
- ROUGH OPENING (SEE CHART)
- FOR DROP IN INSTALLATION FROM ABOVE FLOOR
- 1/2" INTERNAL FIBRE-FREE INSULATION

HEATER ELEMENT:

- 1" NOM. (1.125" OD) COPPER TUBE
- 4.25" x 4.25" ALUMINUM FINN

CORE OPTIONS:

- 1/4"(6) NARROW BAR SPACING
- 15A 0° DEFLECTION
- 16A 15° DEFLECTION
- 1/2"(13) WIDE BAR SPACING
- 15B 0° DEFLECTION
- 16B 15° DEFLECTION
- 25B 0° DEFLECTION
- 26B 15° DEFLECTION
- 27B 30° DEFLECTION
- 7/16"(11) PENCIL PROOF BAR SPACING
- 25C 0° DEFLECTION
- 26C 15° DEFLECTION
- 27C 30° DEFLECTION

GRILLE FINISH OPTIONS:

- B17 - BLACK
- B15 - ALUM. POWDER COAT
- #66 - BRUSHED & CLEAR COAT
- SPL - OPTIONAL FINISHES AVAILABLE
- AC - ANODIZED CLEAR
- ALB - ANODIZED LIGHT BRONZE
- AMB - ANODIZED MEDIUM BRONZE
- ADB - ANODIZED DARK BRONZE
- AB - ANODIZED BLACK
- ASPL - ANODIZED SPECIAL COLOR

ACCESSORIES OPTIONS:

- DV1

ALL METRIC DIMENSIONS () ARE SOFT CONVERTED. IMPERIAL DIMENSIONS ARE CONVERTED TO METRIC AND ROUNDED TO THE NEAREST MILLIMETER.

PROJECT:		price
ENGINEER:		
CUSTOMER:		DS
SUBMITTAL DATE:		255521
SPEC. SYMBOL:		2010/09/09
LFGH-RCV LINEAR FLOOR GRILLE HYDRONIC HEAT RECIRCULATION C/W VARIABLE COOLING		

LFGH - RCV

LFGH-RCV CONTINUOUS:

LENGTHS > 96" ARE SUPPLIED IN SECTIONS TO BE ASSEMBLED ON-SITE.

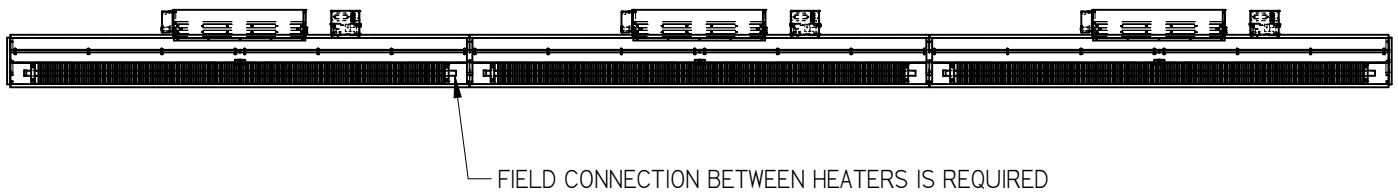
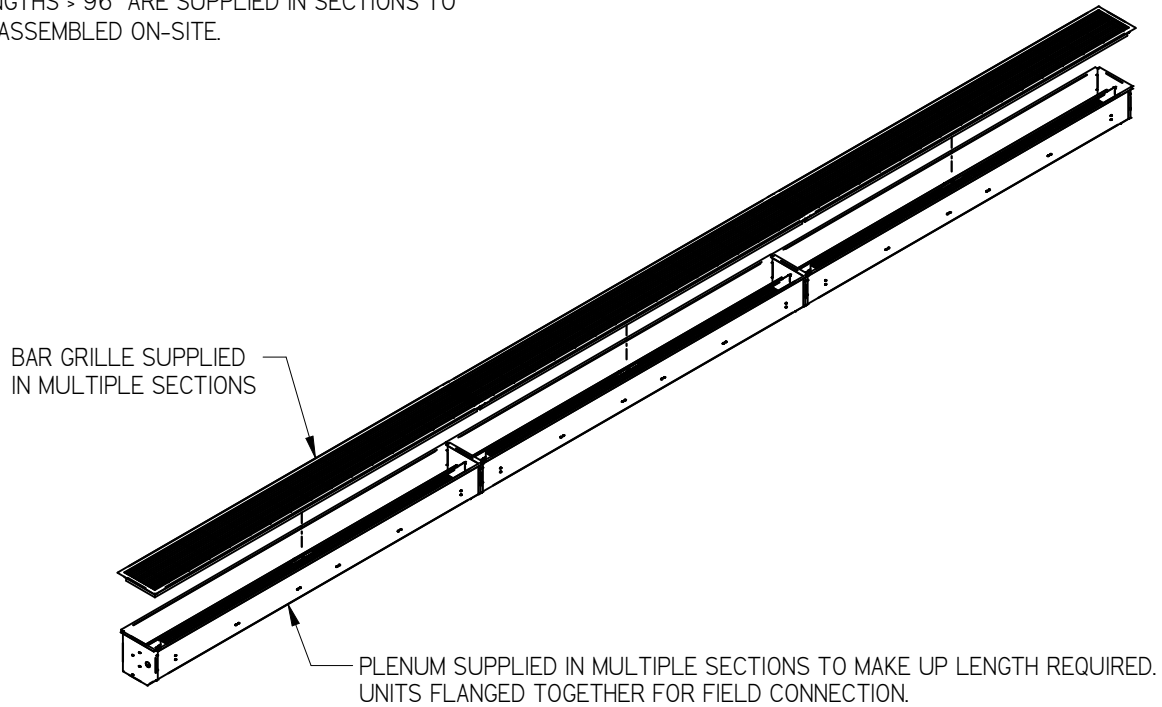

ALL METRIC DIMENSIONS () ARE SOFT CONVERTED. IMPERIAL DIMENSIONS ARE CONVERTED TO METRIC AND ROUNDED TO THE NEAREST MILLIMETER.

PROJECT:		PRICE [®]	
ENGINEER:		DS	LFGH-RCV LINEAR FLOOR GRILLE HYDRONIC HEAT RECIRCULATION C/W VARIABLE COOLING
CUSTOMER:			
SUBMITTAL DATE:	SPEC. SYMBOL:	2010/09/09	

LFGH - RC

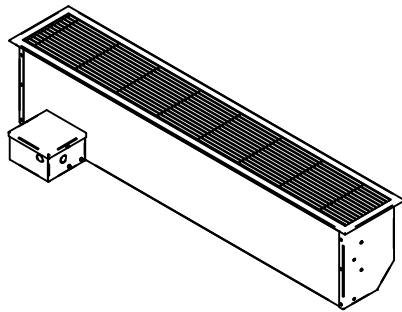
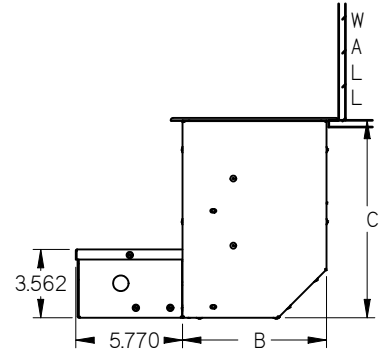
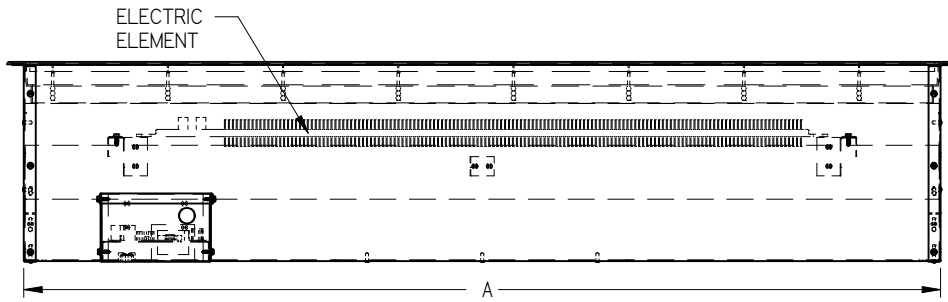

NOM. SIZE	UNIT OVERALL			GRILLE FACE FRAME		ROUGH OPENING	HEAT OUTPUT (W)
	A	B	C	F	G		
24 x 10	23 3/4 (603)	9 3/4 (248)	10 1/2 (267)	25 3/8 (645)	11 1/4 (286)	24 x 10	500
48 x 10	47 3/4 (1213)	9 3/4 (248)	10 1/2 (267)	49 3/8 (1254)	11 1/4 (286)	48 x 10	1000
72 x 10	71 3/4 (1822)	9 3/4 (248)	10 1/2 (267)	73 3/8 (1864)	11 1/4 (286)	72 x 10	1500
96 x 10	95 3/4 (2432)	9 3/4 (248)	10 1/2 (267)	97 3/8 (2473)	11 1/4 (286)	96 x 10	2000

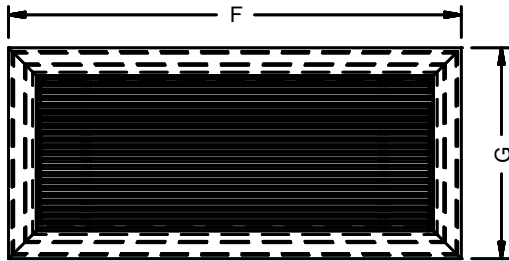

FASTENING DETAILS

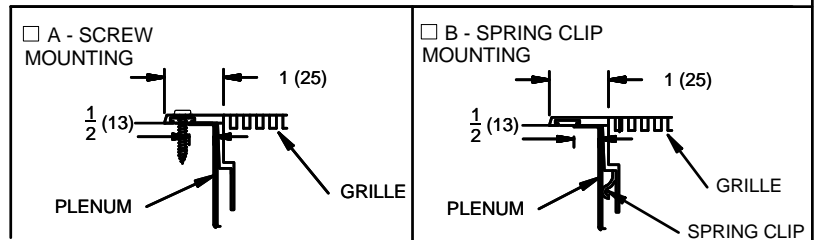

- GRILLE:**
- EXTRUDED ALUMINUM CONSTRUCTION
 - PRESSED CORE WITH REINFORCING SUPPORT BARS
 - 1" FACE FRAME
- PLENUM:**
- BLACK FINISH
 - ROUGH OPENING (SEE CHART)
 - FOR DROP IN INSTALLATION FROM ABOVE FLOOR
 - 1/2" INTERNAL FIBRE-FREE INSULATION
- HEATER ELEMENT:**
- 120/1/60 ELECTRICAL
 - 240/1/60 ELECTRICAL
 - 277/1/60 ELECTRICAL
 - FINNED STRIP HEATER, MULTIPLE ELEMENTS MAY BE SUPPLIED ON LONGER UNITS
 - TRANSFORMERS INCLUDED

- CORE OPTIONS:**
- 1/4"(6) NARROW BAR SPACING
 - 15A 0° DEFLECTION
 - 16A 15° DEFLECTION
 - 1/2"(13) WIDE BAR SPACING
 - 15B 0° DEFLECTION
 - 16B 15° DEFLECTION
 - 25B 0° DEFLECTION
 - 26B 15° DEFLECTION
 - 27B 30° DEFLECTION
 - 7/16"(11) PENCIL PROOF BAR SPACING
 - 25C 0° DEFLECTION
 - 26C 15° DEFLECTION
 - 27C 30° DEFLECTION

- GRILLE FINISH OPTIONS:**
- B17 - BLACK
 - B15 - ALUM. POWDER COAT
 - #66 - BRUSHED & CLEAR COAT
 - SPL - OPTIONAL FINISHES AVAILABLE
 - AC - ANODIZED CLEAR
 - ALB - ANODIZED LIGHT BRONZE
 - AMB - ANODIZED MEDIUM BRONZE
 - ADB - ANODIZED DARK BRONZE
 - AB - ANODIZED BLACK
 - ASPL - ANODIZED SPECIAL COLOR

- ACCESSORIES OPTIONS:**
- DV1



ALL METRIC DIMENSIONS () ARE SOFT CONVERTED. IMPERIAL DIMENSIONS ARE CONVERTED TO METRIC AND ROUNDED TO THE NEAREST MILLIMETER.

PROJECT:		 DS LFGH-RC LINEAR FLOOR GRILLE ELECTRIC HEAT RECIRCULATION
ENGINEER:		
CUSTOMER:		
SUBMITTAL DATE:		
SPEC. SYMBOL:		258474
		2011/06/29

LFGH - RC

LFGH-RC CONTINUOUS:

LENGTHS > 96" ARE SUPPLIED IN SECTIONS TO BE ASSEMBLED ON-SITE.

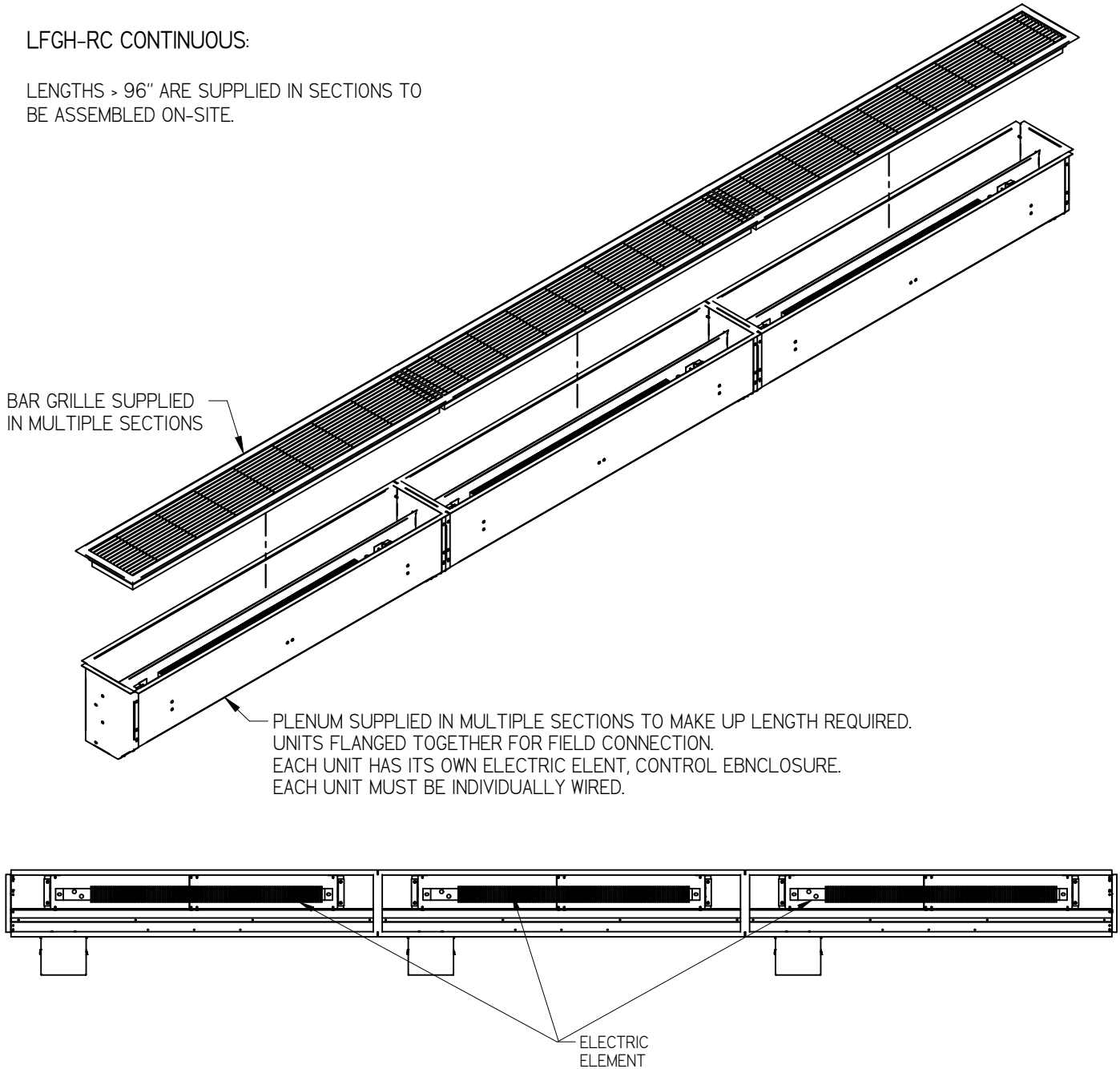

ALL METRIC DIMENSIONS () ARE SOFT CONVERTED. IMPERIAL DIMENSIONS ARE CONVERTED TO METRIC AND ROUNDED TO THE NEAREST MILLIMETER.

PROJECT:		price
ENGINEER:		
CUSTOMER:		DS
SUBMITTAL DATE:		258474
SPEC. SYMBOL:		2011/06/29
LFGH-RC LINEAR FLOOR GRILLE ELECTRIC HEAT RECIRCULATION		

LFGH - RCV

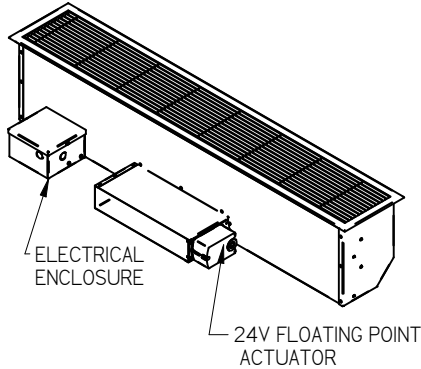
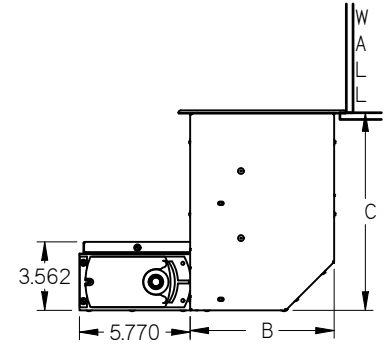
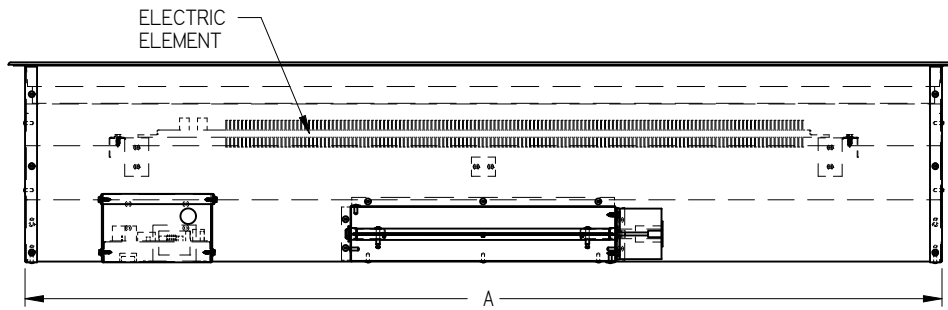

NOM. SIZE	UNIT OVERALL			GRILLE FACE FRAME		ROUGH OPENING	AIRFLOW (CFM)	HEAT OUTPUT (W)
	A	B	C	F	G			
24 x 10	23 3/4 (603)	9 3/4 (248)	10 1/2 (267)	25 3/8 (645)	11 1/4 (286)	24 x 10	100 - 140	500
48 x 10	47 3/4 (1213)	9 3/4 (248)	10 1/2 (267)	49 3/8 (1254)	11 1/4 (286)	48 x 10	200 - 280	1000
72 x 10	71 3/4 (1822)	9 3/4 (248)	10 1/2 (267)	73 3/8 (1864)	11 1/4 (286)	72 x 10	300 - 420	1500
96 x 10	95 3/4 (2432)	9 3/4 (248)	10 1/2 (267)	97 3/8 (2473)	11 1/4 (286)	96 x 10	400 - 560	2000

FASTENING DETAILS

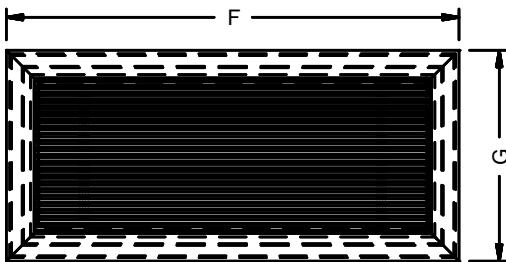
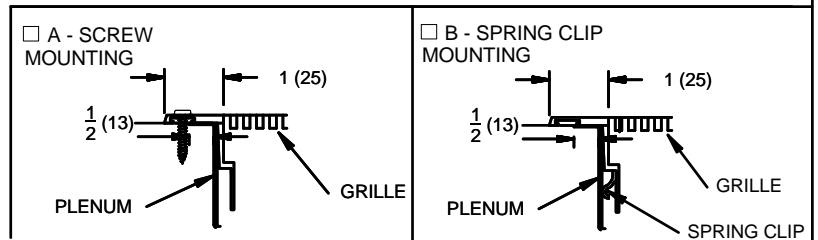

GRILLE:

- EXTRUDED ALUMINUM CONSTRUCTION
- PRESSED CORE WITH REINFORCING SUPPORT BARS
- 1" FACE FRAME

PLENUM:

- BLACK FINISH
- ROUGH OPENING (SEE CHART)
- FOR DROP IN INSTALLATION FROM ABOVE FLOOR
- 1/2" INTERNAL FIBRE-FREE INSULATION

HEATER ELEMENT:

- 120/1/60 ELECTRICAL
- 240/1/60 ELECTRICAL
- 277/1/60 ELECTRICAL
- FINNED STRIP HEATER, MULTIPLE ELEMENTS MAY BE SUPPLIED ON LONGER UNITS
- TRANSFORMERS INCLUDED

CORE OPTIONS:

- 1/4"(6) NARROW BAR SPACING
- 15A 0° DEFLECTION
- 16A 15° DEFLECTION
- 1/2"(13) WIDE BAR SPACING
- 15B 0° DEFLECTION
- 16B 15° DEFLECTION
- 25B 0° DEFLECTION
- 26B 15° DEFLECTION
- 27B 30° DEFLECTION

GRILLE FINISH OPTIONS:

- B17 - BLACK
- B15 - ALUM. POWDER COAT
- #66 - BRUSHED & CLEAR COAT
- SPL - OPTIONAL FINISHES AVAILABLE
- AC - ANODIZED CLEAR
- ALB - ANODIZED LIGHT BRONZE
- AMB - ANODIZED MEDIUM BRONZE
- ADB - ANODIZED DARK BRONZE
- AB - ANODIZED BLACK
- ASPL - ANODIZED SPECIAL COLOR

ACCESSORIES OPTIONS:

- DV1



ALL METRIC DIMENSIONS () ARE SOFT CONVERTED. IMPERIAL DIMENSIONS ARE CONVERTED TO METRIC AND ROUNDED TO THE NEAREST MILLIMETER.

PROJECT:		price
ENGINEER:	DS	
CUSTOMER:	258475	LFGH-RCV LINEAR FLOOR GRILLE ELECTRIC HEAT RECIRCULATION C/W VARIABLE COOLING
SUBMITTAL DATE:	2011/06/29	
SPEC. SYMBOL:		

LFGH - RCV

LFGH-RCV CONTINUOUS:

LENGTHS > 96" ARE SUPPLIED IN SECTIONS TO BE ASSEMBLED ON-SITE.

BAR GRILLE SUPPLIED IN MULTIPLE SECTIONS

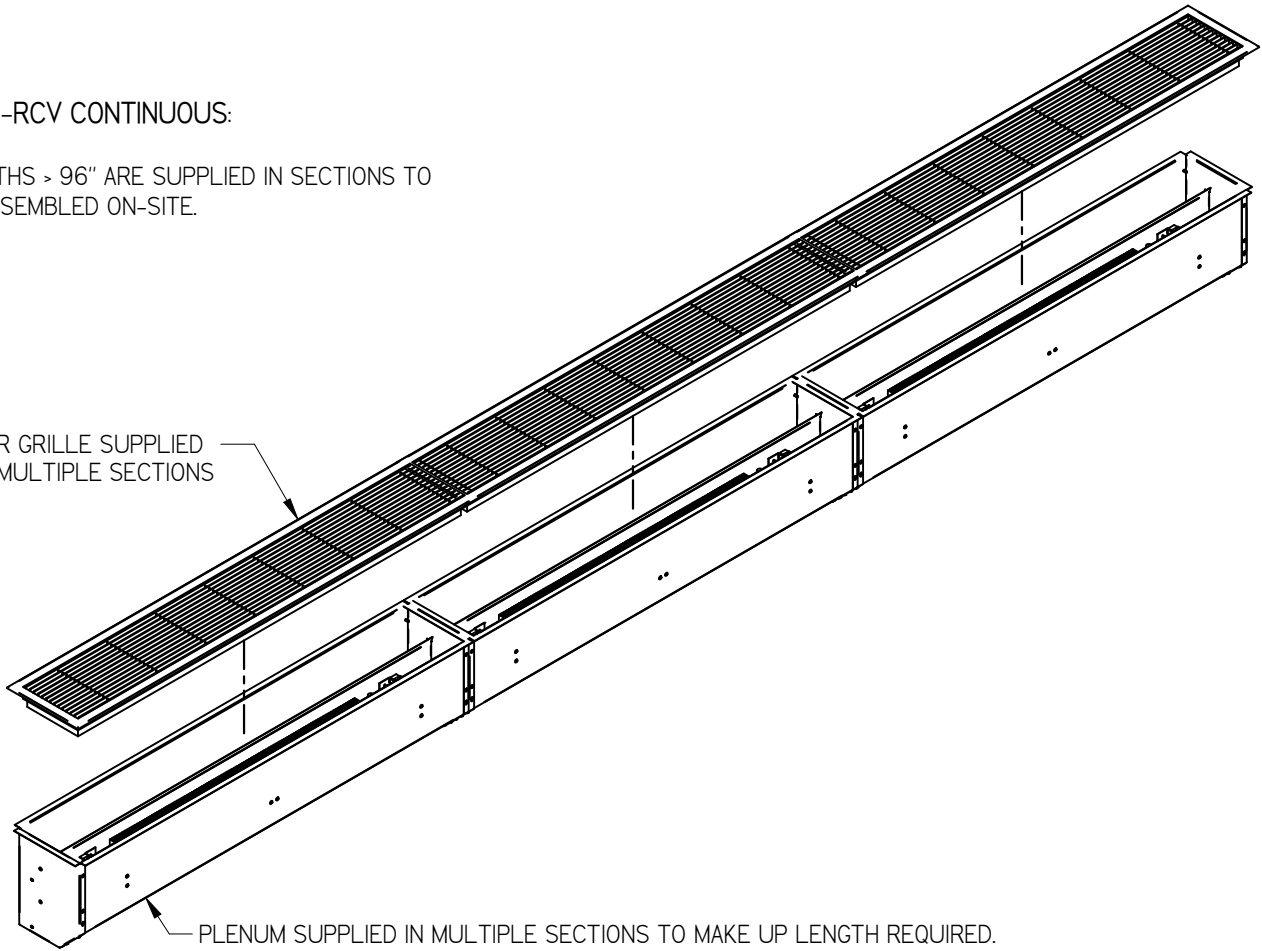

PLENUM SUPPLIED IN MULTIPLE SECTIONS TO MAKE UP LENGTH REQUIRED.
 UNITS FLANGED TOGETHER FOR FIELD CONNECTION.
 EACH UNIT HAS ITS OWN ELECTRICAL ELEMENT, CONTROL ENCLOSURE AND DAMPER.
 EACH UNIT MUST BE INDIVIDUALLY WIRED.

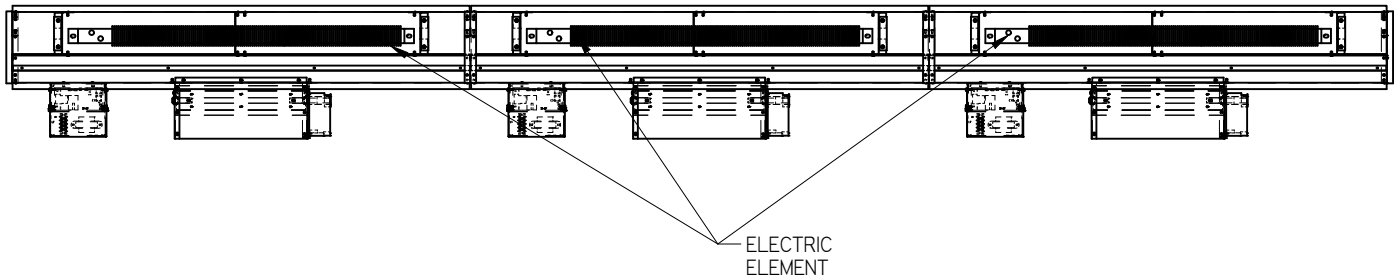

ELECTRIC ELEMENT

ALL METRIC DIMENSIONS () ARE SOFT CONVERTED. IMPERIAL DIMENSIONS ARE CONVERTED TO METRIC AND ROUNDED TO THE NEAREST MILLIMETER.

PROJECT:		price
ENGINEER:		
CUSTOMER:		DS
SUBMITTAL DATE:		258475
SPEC. SYMBOL:		2011/06/29
		LFGH-RCV LINEAR FLOOR GRILLE ELECTRIC HEAT RECIRCULATION C/W VARIABLE COOLING