

STANDARD MOTOR

UNIT SIZE	MOTOR H.P.	FULL LOAD AMPS			
		115V	208V	240V	277V
20	1/8	2.4	1.1	1.1	1.1
30	1/4	5.2	1.8	1.7	1.6
40	1/2	8.0	3.1	3.1	3.1

ECM MOTOR

UNIT SIZE	MOTOR H.P.	FULL LOAD AMPS		
		115V	240V	277V
20	1/2	2.9	1.4	1.2
30	1/2	5.6	2.8	2.5
40	1/2	6.0	2.9	2.9

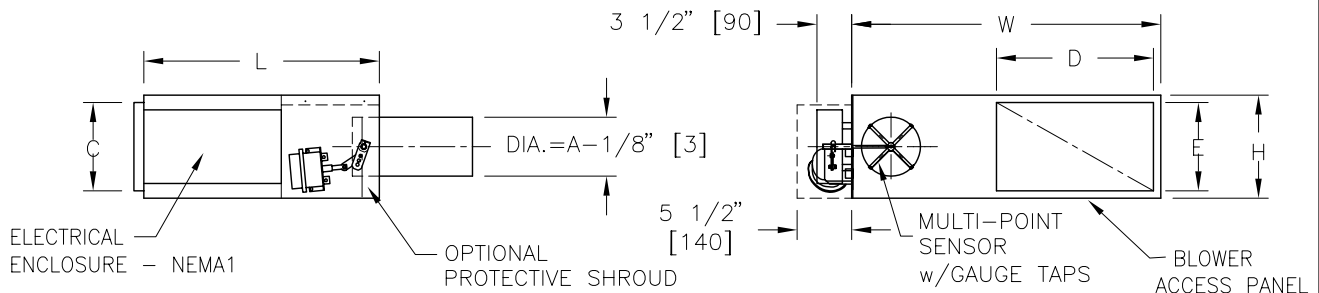
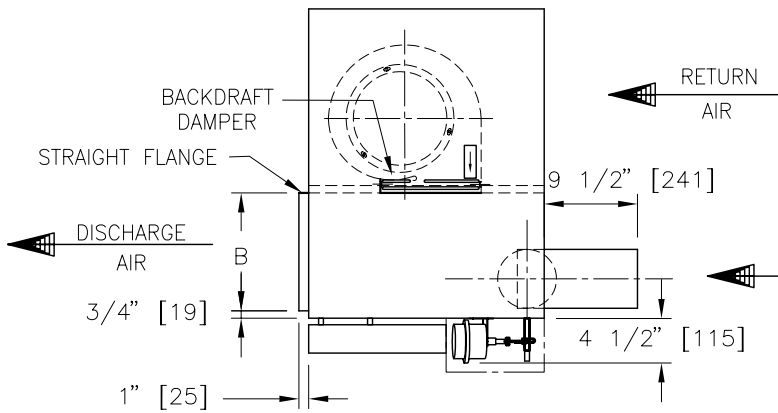

IMPERIAL UNITS (Inches)

UNIT SIZE	MAXIMUM FAN CFM	PRIMARY AIR INLET A	RETURN AIR INLET		OUTLET DUCT SIZE		W	H	L
			D	E	B	C			
20	600	6,8	16	9	12	10	31 1/2	10 1/2	24
30	950	14 X 8	16	9	17	9	39	10 1/2	33
40	1500	14 X 10	16	11	21	11	42 3/4	12 1/2	36

SI UNITS (mm)

UNIT SIZE	MAXIMUM FAN L/S	PRIMARY AIR INLET A	RETURN AIR INLET		OUTLET DUCT SIZE		W	H	L
			D	E	B	C			
20	283	152,203	406	229	305	254	800	267	610
30	448	356 X 203	406	229	432	229	991	267	838
40	708	356 X 254	406	279	533	279	1086	318	914

NOTES:

- INTERNAL INSULATION - FIBERGLASS 1/2" (13mm) THICK, MIN. 1.5# DENSITY WHICH MEETS REQUIREMENTS OF NFPA 90A AND UL181
- 22 GA. ZINC COATED STEEL HOUSING. MECHANICALLY SEALED LEAK RESISTANT CONSTRUCTION.
- ALL CONTROL COMPONENTS UTILIZE 20 PSI (138 kPa) CLEAN, DRY CONTROL AIR.
- UNITS NOT TO BE USED FOR TEMPORARY HEAT OR VENTILATION DURING CONSTRUCTION.
- MINIMUM 0.1" w.g. (25 PA) EXTERNAL STATIC PRESSURE TO OPERATE.
- REFER TO SUBMITTED BOX SCHEDULE FOR AIR VOLUMES & INLET SIZES.
- CONTROLS MOUNTED ON LEFT HAND SIDE OF UNIT AS ILLUSTRATED.
- ELECTRIC MOTORS 1 PHASE, 60 CYCLE.
- LISTED UL1995 & CSA236 ASSEMBLY.



OPTIONS:

- DISCONNECT SWITCH (DSW) PROTECTIVE SHROUD FILTERS
 HANGER BRACKETS (HB) SPRING HANGER BRACKETS (HBS) CAM LATCHES ECM MOTOR
 LINERS: FF50 FB

ALL METRIC DIMENSIONS () ARE SOFT CONVERTED. IMPERIAL DIMENSIONS ARE CONVERTED TO METRIC AND ROUNDED TO THE NEAREST MILLIMETER.

PROJECT:			
ENGINEER:			
CUSTOMER:			FPVLP6000 LOW PROFILE FAN POWERED TERMINALS VARIABLE VOLUME PNEUMATIC CONTROLS
SUBMITTAL DATE:		237116	
SPEC. SYMBOL:		OCT 08	

STANDARD MOTOR

UNIT SIZE	MOTOR H.P.	FULL LOAD AMPS			
		115V	208V	240V	277V
20	1/8	2.4	1.1	1.1	1.1
30	1/4	5.2	1.8	1.7	1.6
40	1/2	8.0	3.1	3.1	3.1

ECM MOTOR

UNIT SIZE	MOTOR H.P.	FULL LOAD AMPS		
		115V	240V	277V
20	1/2	2.9	1.4	1.2
30	1/2	5.6	2.8	2.5
40	1/2	6.0	2.9	2.9

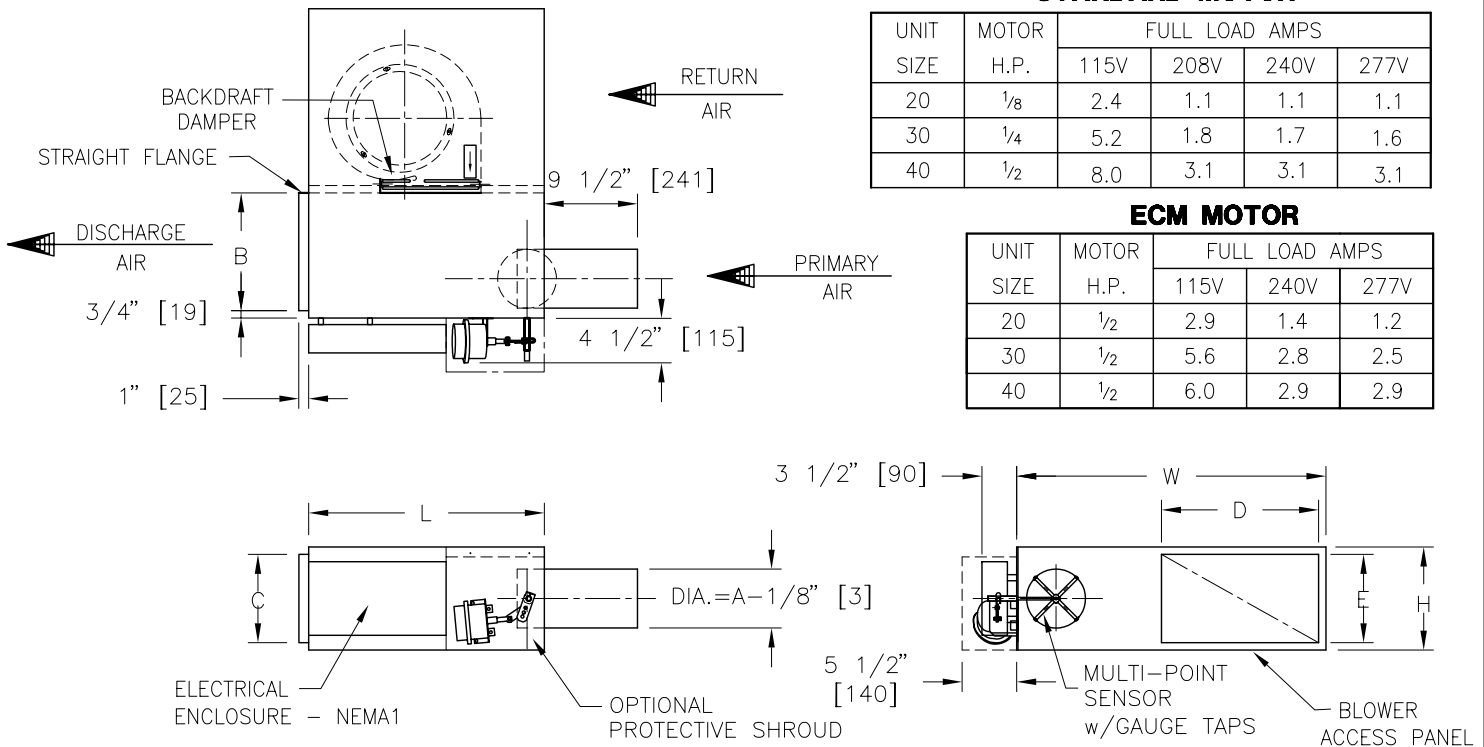

IMPERIAL UNITS (Inches)

UNIT SIZE	MAXIMUM FAN CFM	PRIMARY AIR INLET A	RETURN AIR INLET		OUTLET DUCT SIZE		W	H	L
			D	E	B	C			
20	600	6,8	16	9	12	10	31½	10½	24
30	950	14 X 8	16	9	17	9	39	10½	33
40	1500	14 X 10	16	11	21	11	42¾	12½	36

SI UNITS (mm)

UNIT SIZE	MAXIMUM FAN L/S	PRIMARY AIR INLET A	RETURN AIR INLET		OUTLET DUCT SIZE		W	H	L
			D	E	B	C			
20	283	152,203	406	229	305	254	800	267	610
30	448	356 X 203	406	229	432	229	991	267	838
40	708	356 X 254	406	279	533	279	1086	318	914

NOTES:

- INTERNAL INSULATION – FIBERGLASS 1/2" (13mm) THICK, MIN. 1.5# DENSITY WHICH MEETS REQUIREMENTS OF NFPA 90A AND UL181
- 22 GA. ZINC COATED STEEL HOUSING. MECHANICALLY SEALED LEAK RESISTANT CONSTRUCTION.
- ALL CONTROL COMPONENTS UTILIZE 20 PSI (138 kPa) CLEAN, DRY CONTROL AIR.
- UNITS NOT TO BE USED FOR TEMPORARY HEAT OR VENTILATION DURING CONSTRUCTION.
- MINIMUM 0.1" w.g. (25 PA) EXTERNAL STATIC PRESSURE TO OPERATE.
- REFER TO SUBMITTED BOX SCHEDULE FOR AIR VOLUMES & INLET SIZES.
- CONTROLS MOUNTED ON LEFT HAND SIDE OF UNIT AS ILLUSTRATED.
- ELECTRIC MOTORS 1 PHASE, 60 CYCLE.
- LISTED UL1995 & CSA236 ASSEMBLY.



- OPTIONS:**
- | | | |
|--|---|--------------------------------------|
| <input type="checkbox"/> DISCONNECT SWITCH (DSW) | <input type="checkbox"/> PROTECTIVE SHROUD | <input type="checkbox"/> FILTERS |
| <input type="checkbox"/> HANGER BRACKETS (HB) | <input type="checkbox"/> SPRING HANGER BRACKETS (HBS) | <input type="checkbox"/> CAM LATCHES |
| <input type="checkbox"/> LINERS: <input type="checkbox"/> FF50 <input type="checkbox"/> FB | | <input type="checkbox"/> ECM MOTOR |

ALL METRIC DIMENSIONS () ARE SOFT CONVERTED. IMPERIAL DIMENSIONS ARE CONVERTED TO METRIC AND ROUNDED TO THE NEAREST MILLIMETER.

PROJECT:		<h1>PRICE®</h1>	
ENGINEER: <i>BG</i>			
CUSTOMER:		FPVLP8000 LOW PROFILE FAN POWERED TERMINALS VARIABLE VOLUME PNEUMATIC CONTROLS	
SUBMITTAL DATE: OCT 08			
SPEC. SYMBOL:			

STANDARD MOTOR

UNIT SIZE	MOTOR H.P.	FULL LOAD AMPS			
		115V	208V	240V	277V
20	1/8	2.4	1.1	1.1	1.1
30	1/4	5.2	1.8	1.7	1.6
40	1/2	8.0	3.1	3.1	3.1

ECM MOTOR

UNIT SIZE	MOTOR H.P.	FULL LOAD AMPS		
		115V	240V	277V
20	1/2	2.9	1.4	1.2
30	1/2	5.6	2.8	2.5
40	1/2	6.0	2.9	2.9

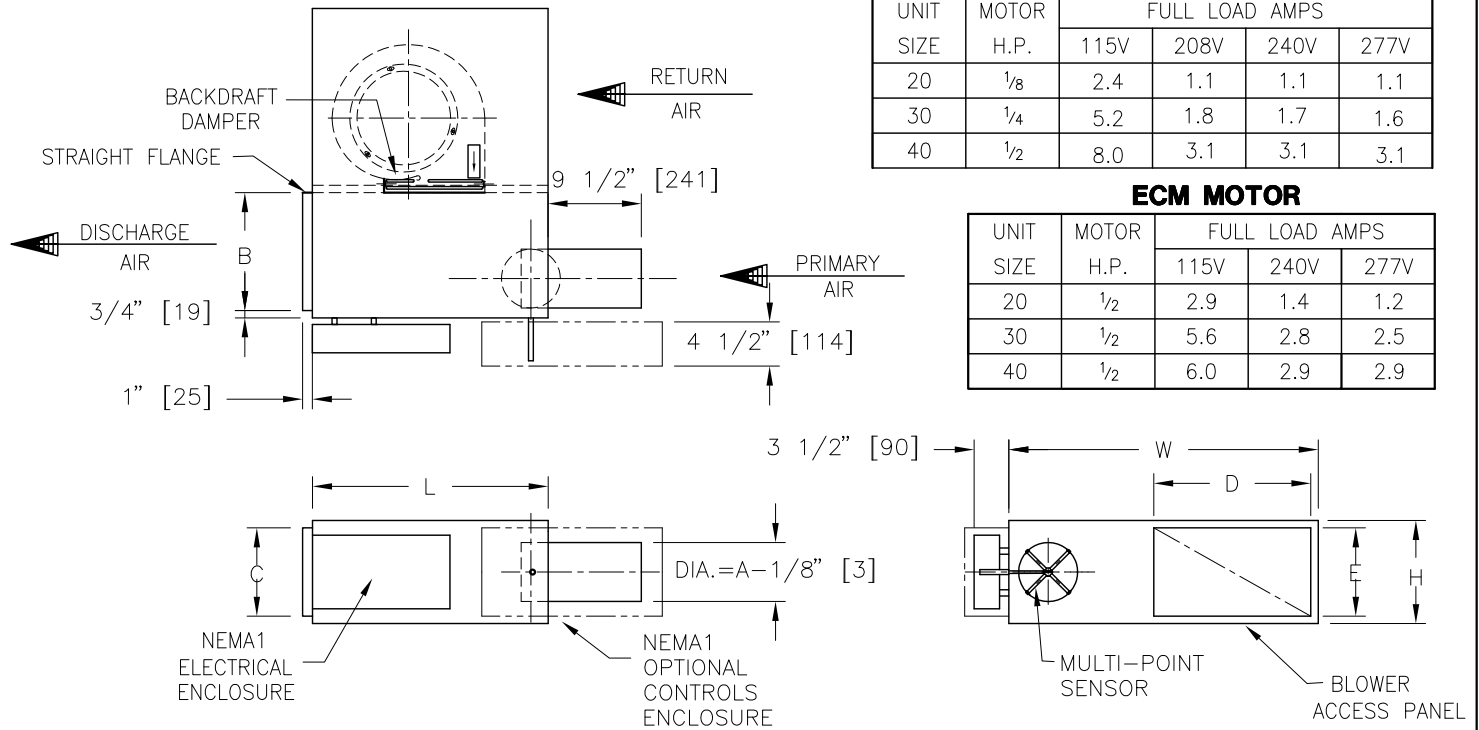

IMPERIAL UNITS (Inches)

UNIT SIZE	MAXIMUM FAN CFM	PRIMARY AIR INLET A	RETURN AIR INLET		OUTLET DUCT SIZE		W	H	L
			D	E	B	C			
20	600	6,8	16	9	12	10	31 1/2	10 1/2	24
30	950	14 X 8	16	9	17	9	39	10 1/2	33
40	1500	14 X 10	16	11	21	11	42 3/4	12 1/2	36

SI UNITS (mm)

UNIT SIZE	MAXIMUM FAN L/S	PRIMARY AIR INLET A	RETURN AIR INLET		OUTLET DUCT SIZE		W	H	L
			D	E	B	C			
20	283	152,203	406	229	305	254	800	267	610
30	448	356 X 203	406	229	432	229	991	267	838
40	708	356 X 254	406	279	533	279	1086	318	914

NOTES:

- INTERNAL INSULATION – FIBERGLASS 1/2" (13mm) THICK, MIN. 1.5# DENSITY WHICH MEETS REQUIREMENTS OF NFPA 90A AND UL181
- 22 GA. ZINC COATED STEEL HOUSING. MECHANICALLY SEALED LEAK RESISTANT CONSTRUCTION.
- DIGITAL CONTROLS BY CONTROL CONTRACTOR.
- UNITS NOT TO BE USED FOR TEMPORARY HEAT OR VENTILATION DURING CONSTRUCTION.
- MINIMUM 0.1" w.g. (25 PA) EXTERNAL STATIC PRESSURE TO OPERATE. (UNITS WITH ELECTRIC HEAT REQUIRE MINIMUM 0.2" w.g. (50 PA))
- REFER TO SUBMITTED BOX SCHEDULE FOR AIR VOLUMES & INLET SIZES.
- CONTROLS MOUNTED ON LEFT HAND SIDE OF UNIT AS ILLUSTRATED.
- ELECTRIC MOTORS 1 PHASE, 60 CYCLE.
- HOT WATER COILS ON RETURN AIR INLET.
- LISTED UL1995 & CSA236 ASSEMBLY.

OPTIONS:

- DISCONNECT SWITCH (DSW) FILTERS CONTROLS ENCLOSURE
 HANGER BRACKETS (HB) SPRING HANGER BRACKETS (HBS) CAM LATCHES ECM MOTOR
 LINERS: FF50 FB

ALL METRIC DIMENSIONS () ARE SOFT CONVERTED. IMPERIAL DIMENSIONS ARE CONVERTED TO METRIC AND ROUNDED TO THE NEAREST MILLIMETER.



PROJECT:



ENGINEER:

BE

CUSTOMER:

237119

SUBMITTAL DATE:

SPEC. SYMBOL:

2007/03/15

FDVLP5000
 LOW PROFILE
 FAN POWERED TERMINALS
 VARIABLE VOLUME
 DIGITAL CONTROLS

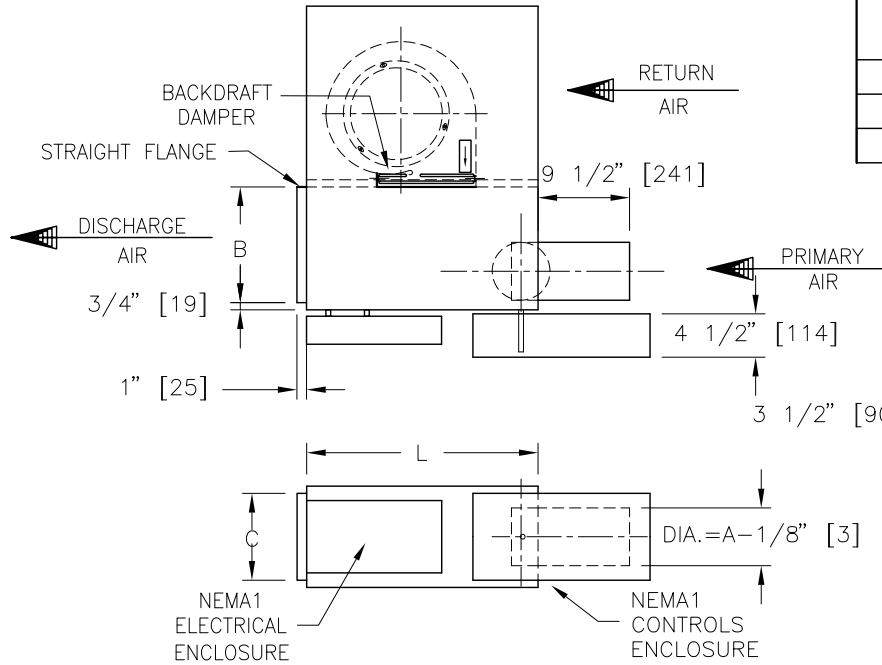

STANDARD MOTOR

UNIT SIZE	MOTOR H.P.	FULL LOAD AMPS			
		115V	208V	240V	277V
20	1/8	2.4	1.1	1.1	1.1
30	1/4	5.2	1.8	1.7	1.6
40	1/2	8.0	3.1	3.1	3.1

ECM MOTOR

UNIT SIZE	MOTOR H.P.	FULL LOAD AMPS		
		115V	240V	277V
20	1/2	2.9	1.4	1.2
30	1/2	5.6	2.8	2.5
40	1/2	6.0	2.9	2.9

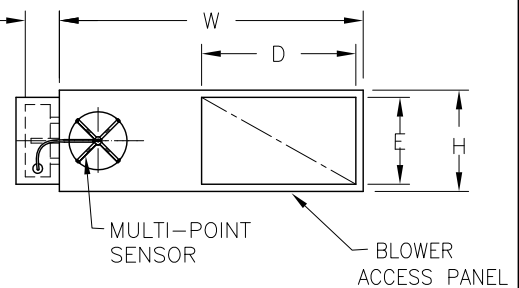

IMPERIAL UNITS (Inches)

UNIT SIZE	MAXIMUM FAN CFM	PRIMARY AIR INLET A	RETURN AIR INLET		OUTLET DUCT SIZE		W	H	L
			D	E	B	C			
20	600	6,8	16	9	12	10	31 1/2	10 1/2	24
30	950	14 X 8	16	9	17	9	39	10 1/2	33
40	1500	14 X 10	16	11	21	11	42 3/4	12 1/2	36

SI UNITS (mm)

UNIT SIZE	MAXIMUM FAN L/S	PRIMARY AIR INLET A	RETURN AIR INLET		OUTLET DUCT SIZE		W	H	L
			D	E	B	C			
20	283	152,203	406	229	305	254	800	267	610
30	448	356 X 203	406	229	432	229	991	267	838
40	708	356 X 254	406	279	533	279	1086	318	914

NOTES:

- INTERNAL INSULATION – FIBERGLASS 1/2" (13mm) THICK, MIN. 1.5# DENSITY WHICH MEETS REQUIREMENTS OF NFPA 90A AND UL181
- 22 GA. ZINC COATED STEEL HOUSING. MECHANICALLY SEALED LEAK RESISTANT CONSTRUCTION.
- UNITS NOT TO BE USED FOR TEMPORARY HEAT OR VENTILATION DURING CONSTRUCTION.
- MINIMUM 0.1" w.g. (25 PA) EXTERNAL STATIC PRESSURE TO OPERATE. (UNITS WITH ELECTRIC HEAT REQUIRE MINIMUM 0.2" w.g. (50 PA))
- REFER TO SUBMITTED BOX SCHEDULE FOR AIR VOLUMES & INLET SIZES.
- CONTROLS MOUNTED ON LEFT HAND SIDE OF UNIT AS ILLUSTRATED.
- ELECTRIC MOTORS 1 PHASE, 60 CYCLE.
- HOT WATER COILS ON RETURN AIR INLET.
- LISTED UL1995 & CSA236 ASSEMBLY.
- PRICE CONTROLS FACTORY MOUNTED.
- PRICE THERMOSTAT FIELD MOUNTED.



OPTIONS:

- DISCONNECT SWITCH (DSW) FILTERS CAM LATCHES
 HANGER BRACKETS (HB), SHIPPED LOOSE SPRING HANGER BRACKETS (HBS) ECM MOTOR
 LINERS: FF50 FB

ALL METRIC DIMENSIONS () ARE SOFT CONVERTED. IMPERIAL DIMENSIONS ARE CONVERTED TO METRIC AND ROUNDED TO THE NEAREST MILLIMETER.

PROJECT:		PRICE [®]	
ENGINEER:		BG	FDVLP8000 LOW PROFILE FAN POWERED TERMINALS VARIABLE VOLUME PRICE CONTROLS
CUSTOMER:		240370	
SUBMITTAL DATE:	SPEC. SYMBOL:	2011/04/19	