



PRICE[®]

COMMERCIAL DUCT SILENCER

 **PRICE**[®]
noise CONTROL
INSTALLATION MANUAL

Date: 04/10
Reference #: M-10

www.price-hvac.com

Contents

Commercial Duct Silencer Installation Instructions 3-5

Sealing the Silencer into the Duct System 6

Maintenance 6

Silencer Flange Installation 7

Welding Method 7

Fastener Method 8

Nested Elbow Silencer 9-15

Commercial Duct Silencer Installation Instructions

Standard Price Rectangular and Elbow silencers are supplied with a 1" slip connection on both ends. To install the silencer into the ducting, one of the following four methods is recommended:

S-Clip with Sheet metal screw (by others)

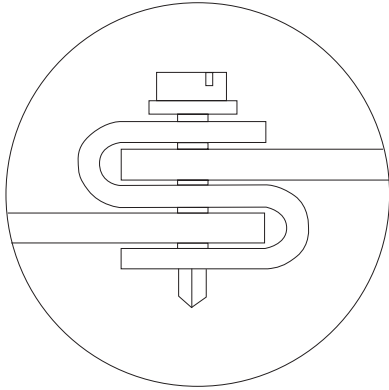

Bolted through gasketed flanges (by others)

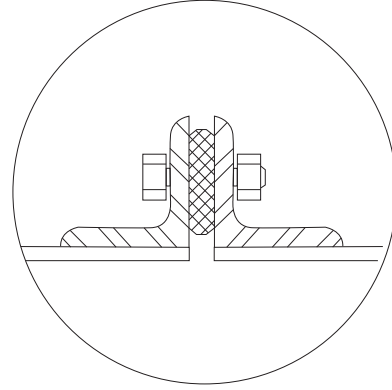

Lapped and Sealed with caulking (by others)

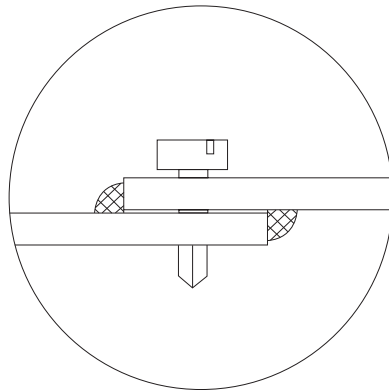

U-shaped steel clip (by others)

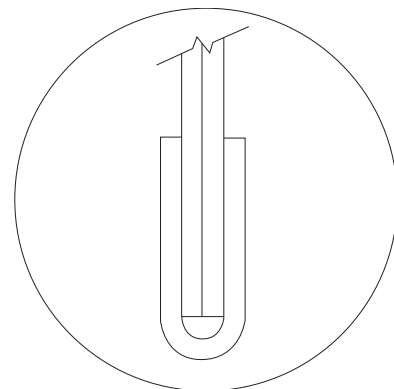

Price silencers larger than 48 inches (1200 mm) are typically made up of multiple components. These components are shipped individually and must be assembled into banks on site.

- The silencer components need to first be stacked side by side and/or one on top of another, depending on the required silencer configuration.
- To ensure the structural integrity of the silencer bank, it is recommended that a minimum of two steel bands be placed around the complete assembly. This will ensure the components of the silencer bank are held tightly together and can be well sealed.
- Before installing the silencer bank, special care should be taken to seal between the edges of each component to ensure that no air leaks between the individual pieces. A "U" shaped steel clip should be placed over each adjacent surface and both ends of the silencer. The "U" shaped clips will hold the components together and complete the silencer bank.

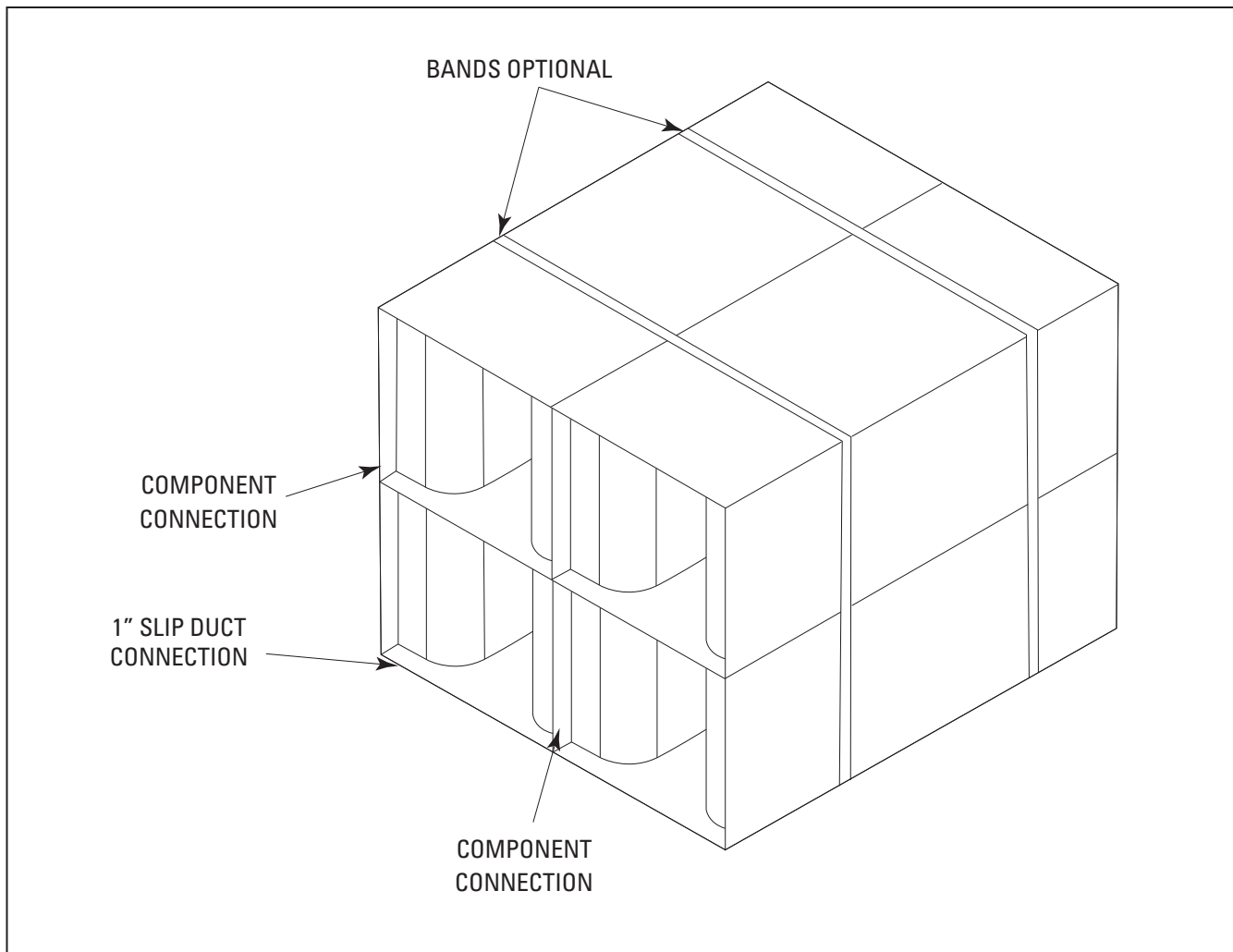

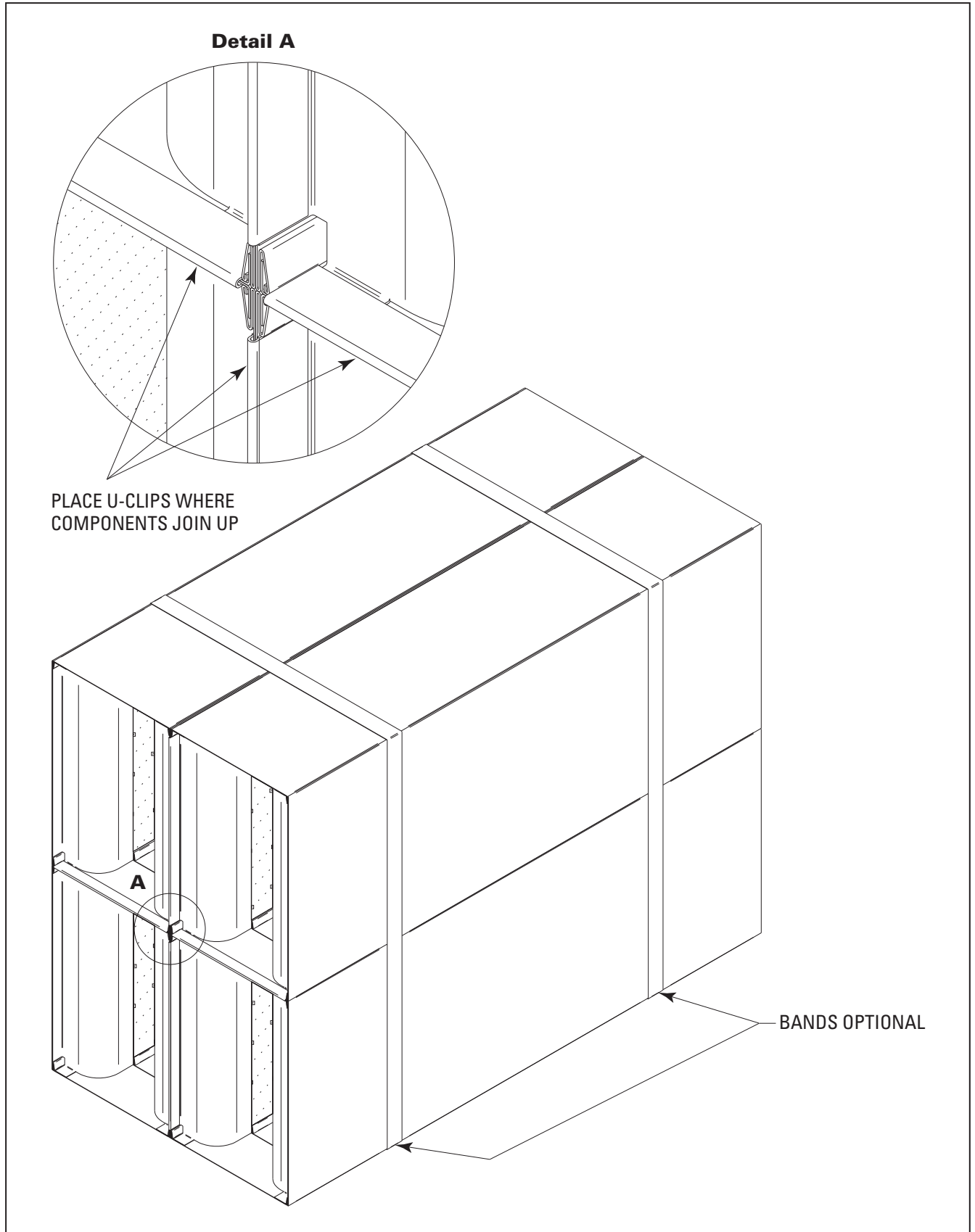

Sealing the Silencer into the Duct System

In order to best utilize the silencer as designed, the installer must ensure that the silencer installation and duct system are airtight.

All joints and connection areas should be sealed with a mastic sealant that is approved for use by the duct manufacturer.

All sealants that are used during the silencer installation should be applied to a clean and dry surface that is free of any contaminants. If contaminants are present during the silencer installation it will need to be cleaned prior to installation.

Maintenance

Price absorptive silencers have no moving parts and therefore very little maintenance is required. Periodic cleaning of the silencers should be performed to remove any dust or contaminants that may have built up in the ducts. The acoustic media that is used in Price absorptive silencers is protected by a perforated metal liner and will not be affected by standard duct cleaning processes.

Please note only minimal amounts of water or other liquids should be used when cleaning absorptive silencers.

The frequency of silencer cleanings will be dependent on the specific application and site conditions, and should be performed with the rest of the duct system cleaning.

Price Packless silencers may be cleaned with chemicals or water as needed, but proper drainage and removal of the liquid is necessary. For silencers that are exposed to harsh environments and require frequent cleaning of the duct system, custom drainage plugs can be added.

Silencer Flange Installation

When flange connections are supplied loose to be installed by the contractor, the following guidelines shall be used to attach them to commercial silencers.

- Flange connections should first be aligned with the duct connection of the silencer.
- Clamp the flanges in the desired orientation to the end of the silencer.

Two methods for flange installation are provided in this section, including the method and Fastener method.

The Welding method is the recommended installation method for silencer flanges.

Welding Method

- Tack or Stitch welding flanges to silencer components is recommended whenever possible and is the preferred method of installation.
- Size and placement of the welds can vary depending on the overall size of the silencer component or bank.

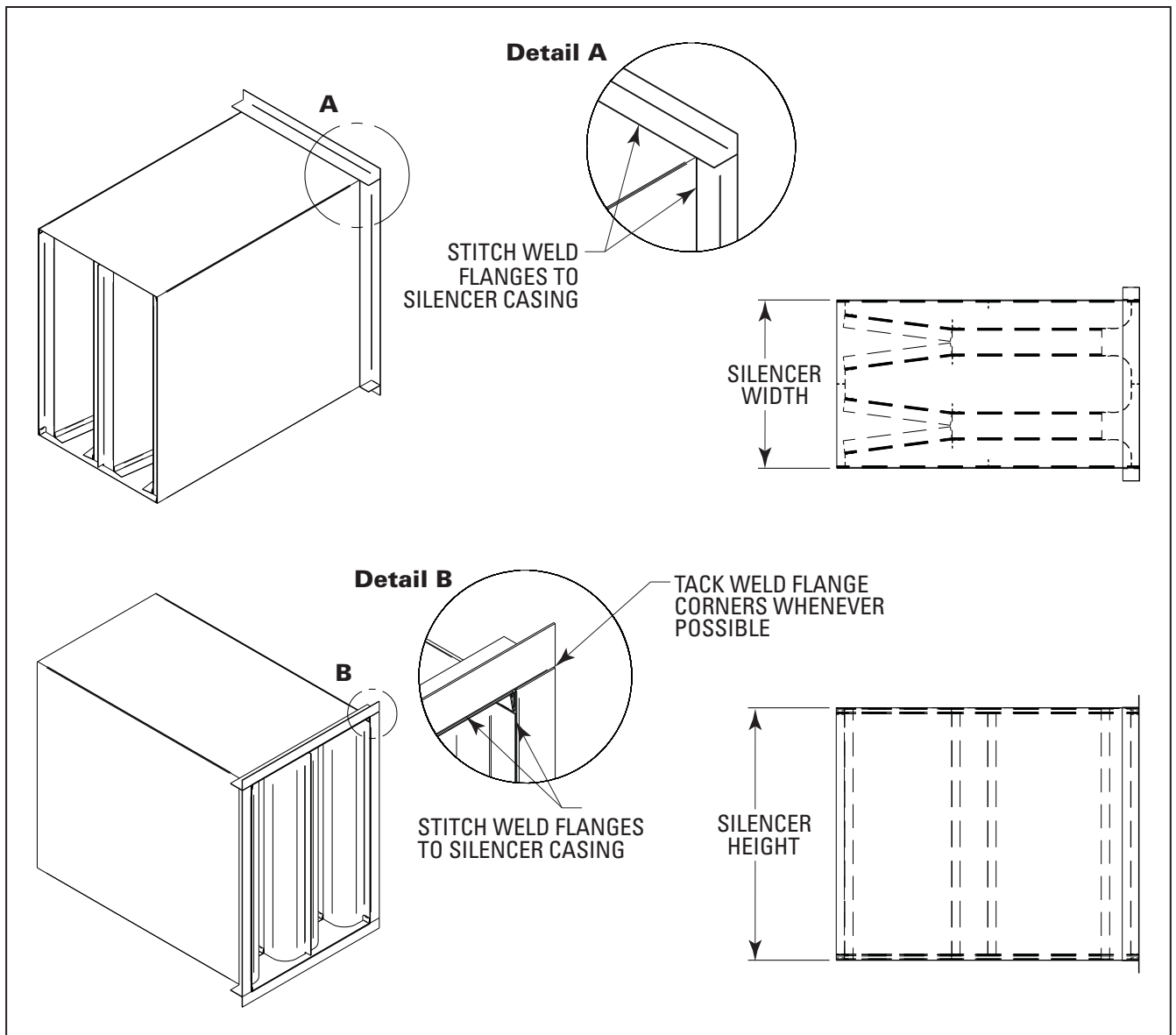

Fastener Method

- If welding equipment is not available, flanges may be installed using mechanical fasteners.
- Depending on the application and size of the silencer bank, either sheet metal screws or nuts and bolts may be used to fasten the flanges to silencer inlets and outlets.
- Whenever possible minimize the amount of fasteners that enter the airstream. Installation of the fasteners should be done either into the baffle or to ensure the "head" of the fastener is inside the silencer whenever possible
- See the figures below for the recommended fastener location and spacing.

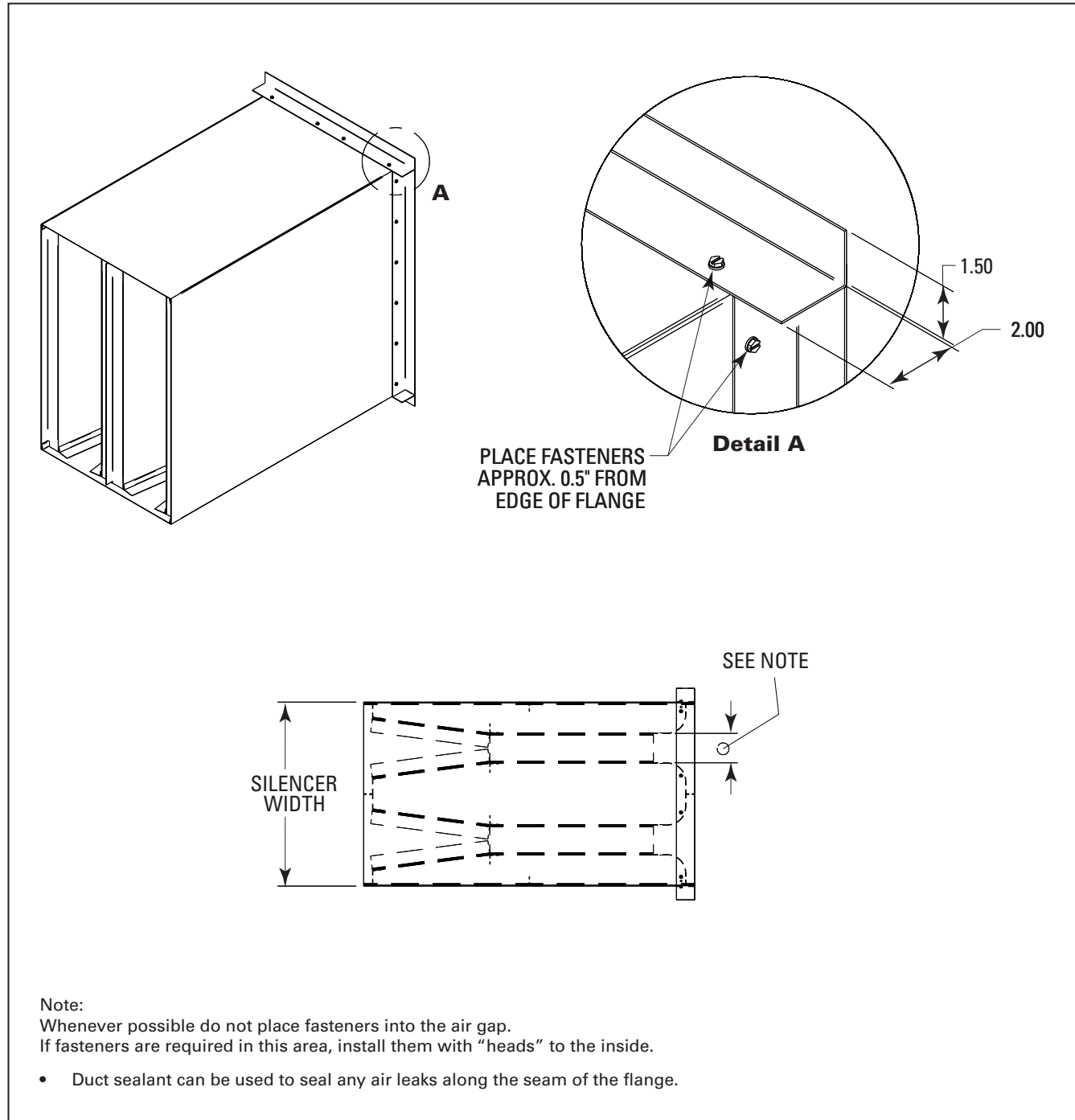

Nested Elbow Silencer

The elbow silencer configuration will be nested when the bank width is made up of multiple components. These silencer components are shipped separately for installation on site by others along with duct extension pieces. Duct extensions are necessary in order to make an even duct connection at the silencer inlet and outlet.

1. All silencer components that make up a nested elbow bank are constructed identically. To make the duct connection of the silencer components line up, duct extension pieces for the inlet and outlet of the silencer component are provided separately.

(See Figure 1.1)

I. Elbow silencer components x 2

II. Duct extensions x 2

Note: For silencers that are banked in the height, each level of the silencer receives the same quantity of components and duct extensions.

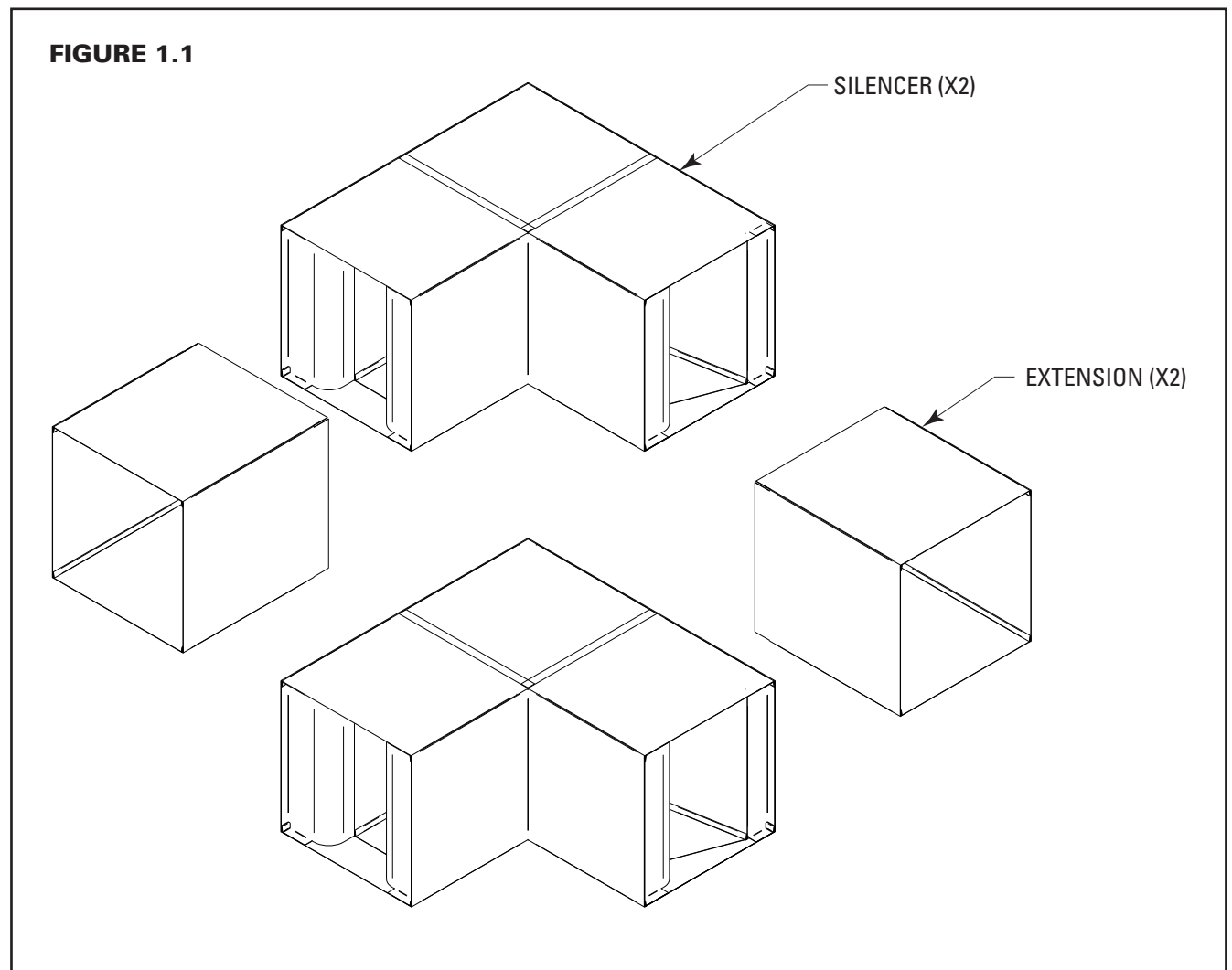

2. Install a duct extension on both the inlet and outlet of one of the silencer components, creating the outer silencer component. When assembling larger silencer components it may be easier to slip the duct extension on with the inlet or outlet facing upwards. The duct extension should slip onto the silencer component 2" or until the lock forms butt together. Do not use any fasteners at this time, as some movement may be needed to align the components.

(See Figure 1.2)

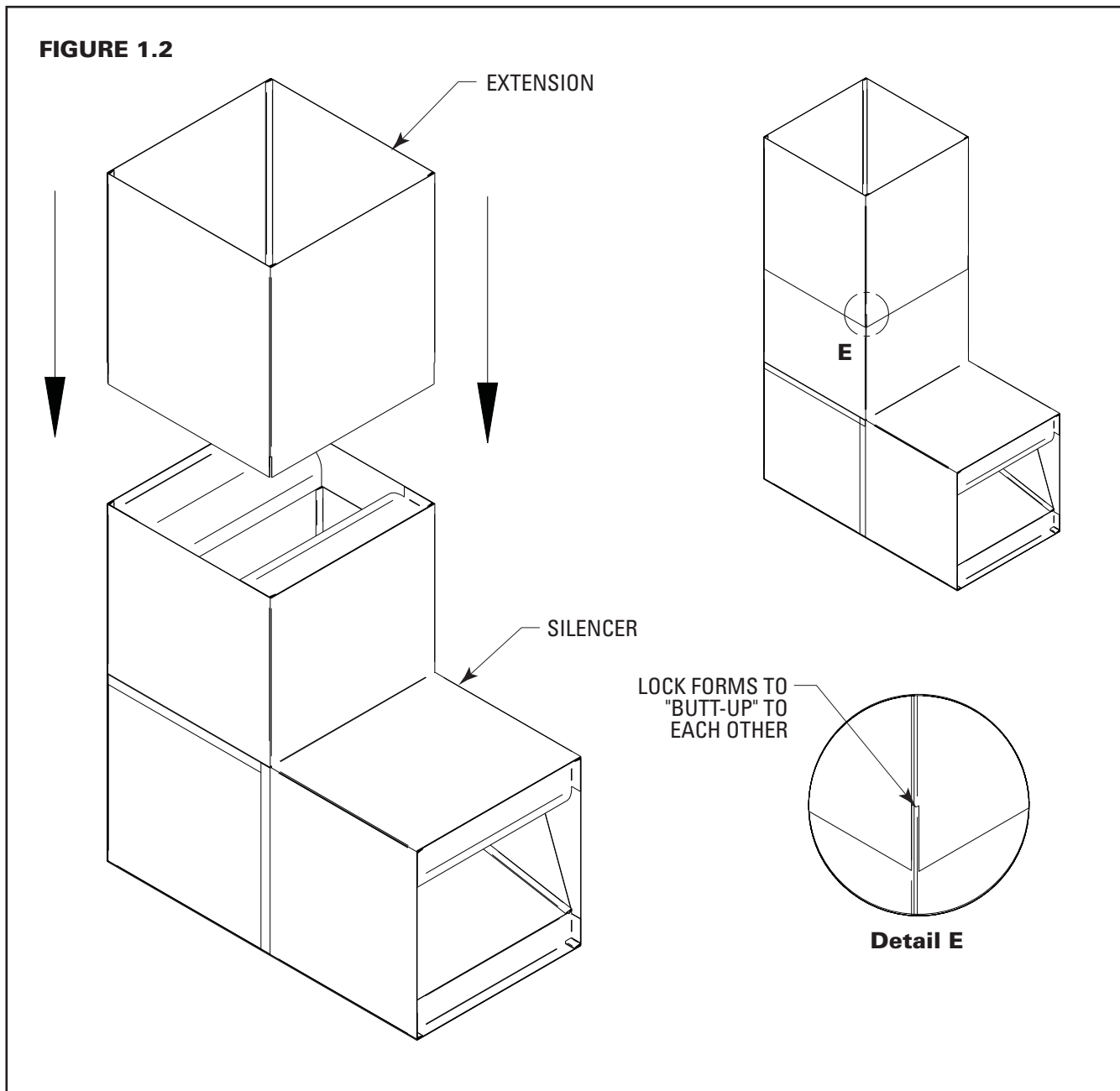

3. Lay the silencer component with the duct extensions connected flat on the ground. Nest the inner silencer component inside of the outer elbow silencer component. Clamp from the inside corner of the inner component to the outside corner of the outer component. This will ensure the silencer is "nested" as much as possible.

(See Figure 1.3)

4. Line up the edges of the duct extensions to the inlet and outlet of the inner silencer component, be sure that the top panels of the duct extension and silencer component are flush (Detail A). Using self tapping sheet metal screws, fasten the inside panel of the extension to the inner silencer component (Detail B). Place sheet metal screws a minimum of 1" from the back edge.

(See Figure 1.3)

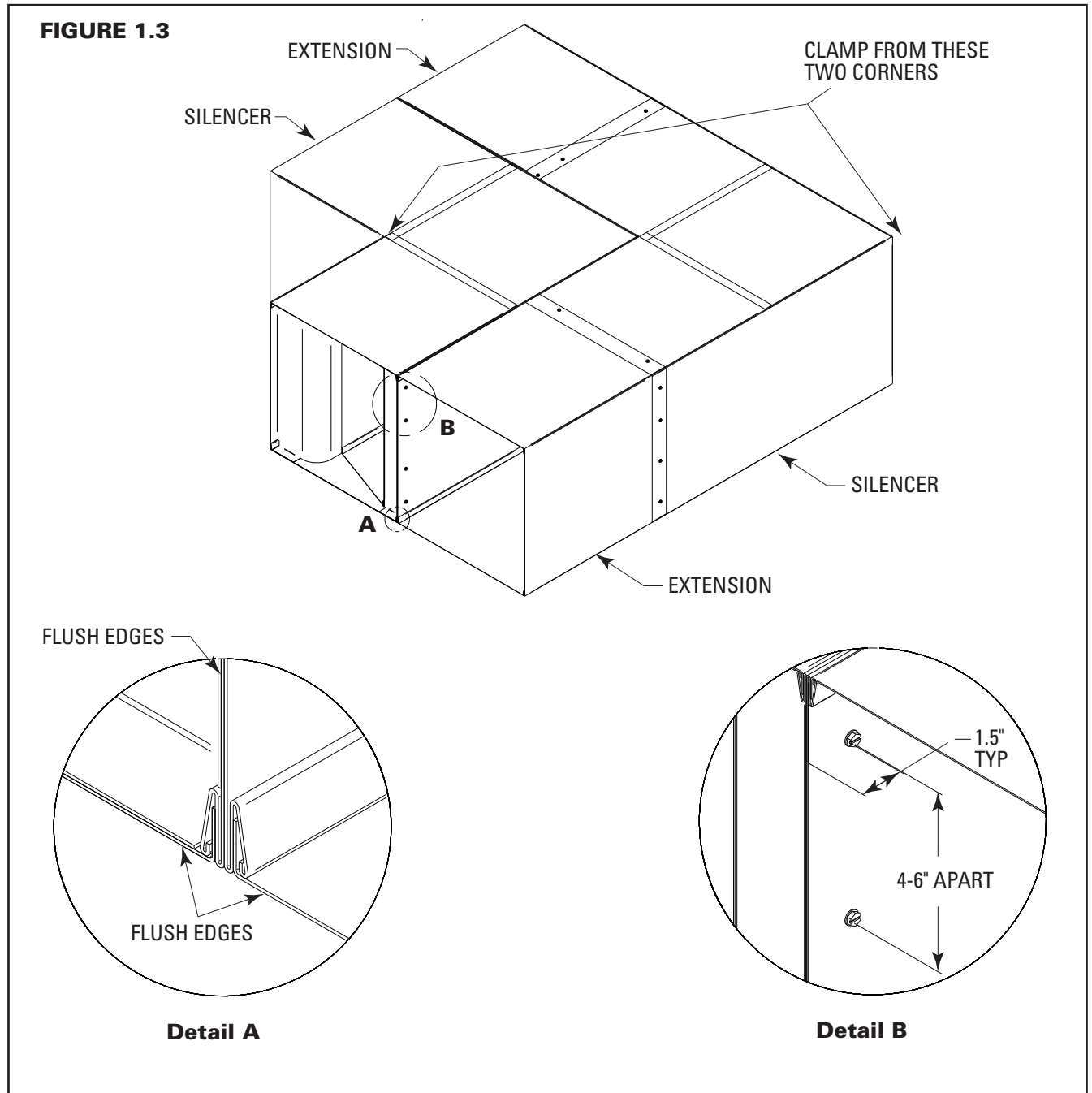

5. Measure the overall length of Leg A and Leg B from the outside corner to the edge of the extension and check that it is within tolerance. Insert sheet metal screws along the slip connection of the outer silencer into the side of the duct extensions (Detail C). Keep the screws within 1" of the duct extension edge. Repeat the process on the opposite leg.

(See Figure 1.4)

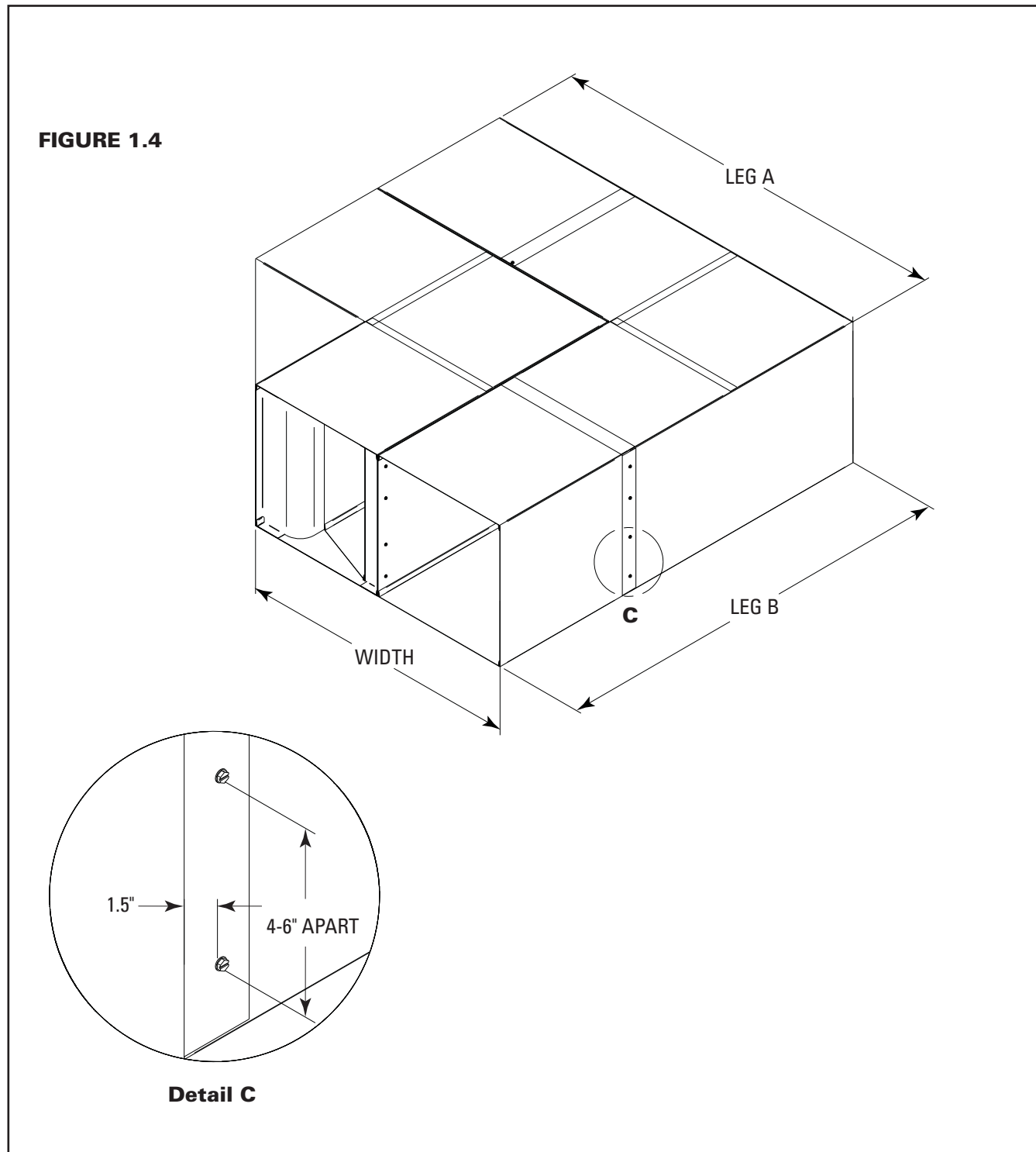

6. Measure the air gaps on the inner elbow silencer component and transfer measurements to outer elbow silencer component. Place screws along the top edge of the duct extension into the top panel of the silencer component, ensuring not to place any screws into the air stream. The screws should be inserted through the top panel of the silencer into the baffle of the silencer. Repeat this process on the opposite leg.

(See Figure 1.5)

FIGURE 1.5

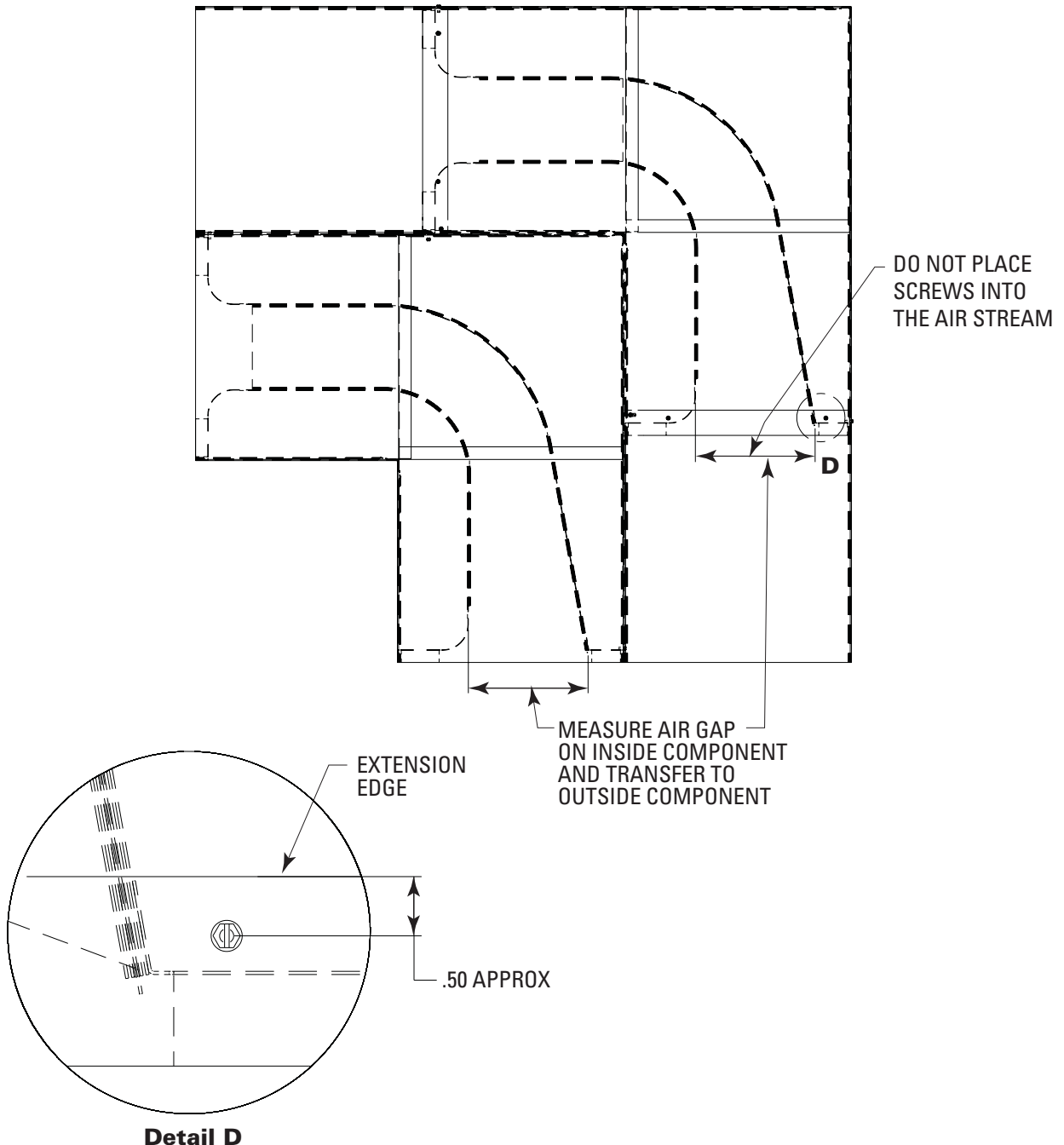

7. Using joiner strips, fasten the corner of the inner component to the inside corner of the outer component.
(See Figure 1.6)
8. Rotate the complete silencer upside down and repeat steps 6 and 7 on the bottom.
9. Apply duct sealant around all of the duct extension joints.

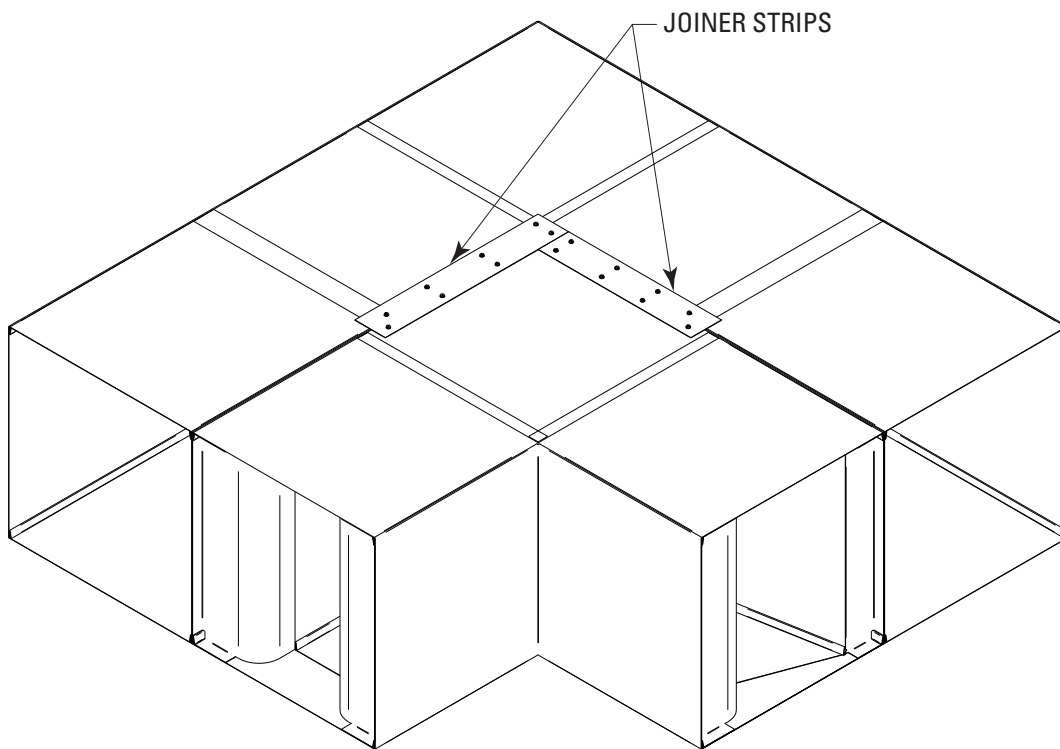
FIGURE 1.6



PRICE
INDUSTRIES

2975 Shawnee Ridge Court
Suwanee, Georgia USA 30024
Ph: 770.623.8050 Fax: 770.623.6404



PRICE
INDUSTRIES

1290 Barrow Industrial Parkway
Auburn, Georgia USA 30011



PRICE
INDUSTRIES

999 North Thornton Road
Casa Grande, Arizona USA 85222-3809



e.h. price
LIMITED

638 Raleigh Street
Winnipeg, Manitoba Canada R2K 3Z9
Ph: 204.669.4220 Fax: 204.663.2715

The founding principles of our company have never changed - business integrity, first class service and a commitment to people. Price manufacturing endeavors arose from our belief that we could supply superior products and services at a reasonable price. Our mission is to become the worldwide supplier of preference for air distribution products and services. You can rely on Price – our products and services – with confidence.

Warranty: The Company warrants and guarantees that all goods within this catalog that have been manufactured by the Company have been manufactured in accordance with the specifications published herein and will be free from defects in material and workmanship for a period of twelve (12) months from the date of Bill of Lading issued by the Company. The Company will replace defective product at its option, but will not be responsible for labor or material charges in replacing product or consequential damages. Any installation not conforming with the Company's specifications, manuals, bulletins or instructions or any misuse or any modification not authorized by the Company voids this warranty. This warranty is in lieu of all Provincial, State, and Federal statutory warranties and the conditions herein are in substitution and replacement of such warranties, statutory or otherwise.

Your Local Price Representative:

Grilles & Diffusers

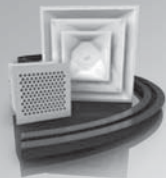

Critical Environments

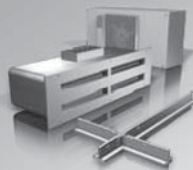

Terminals



Sustainable Building



Noise Control

