



PRICE[®]

**DLE-H (HOT WATER) SINGLE UNIT
DISPLACEMENT VENTILATION
INSTALLATION & SERVICE MANUAL
II-00004**

Date: 04/12
Reference #: J-10d

www.price-hvac.com

Installation Instructions

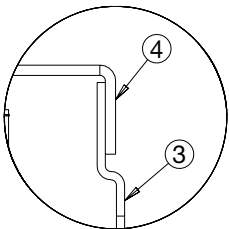
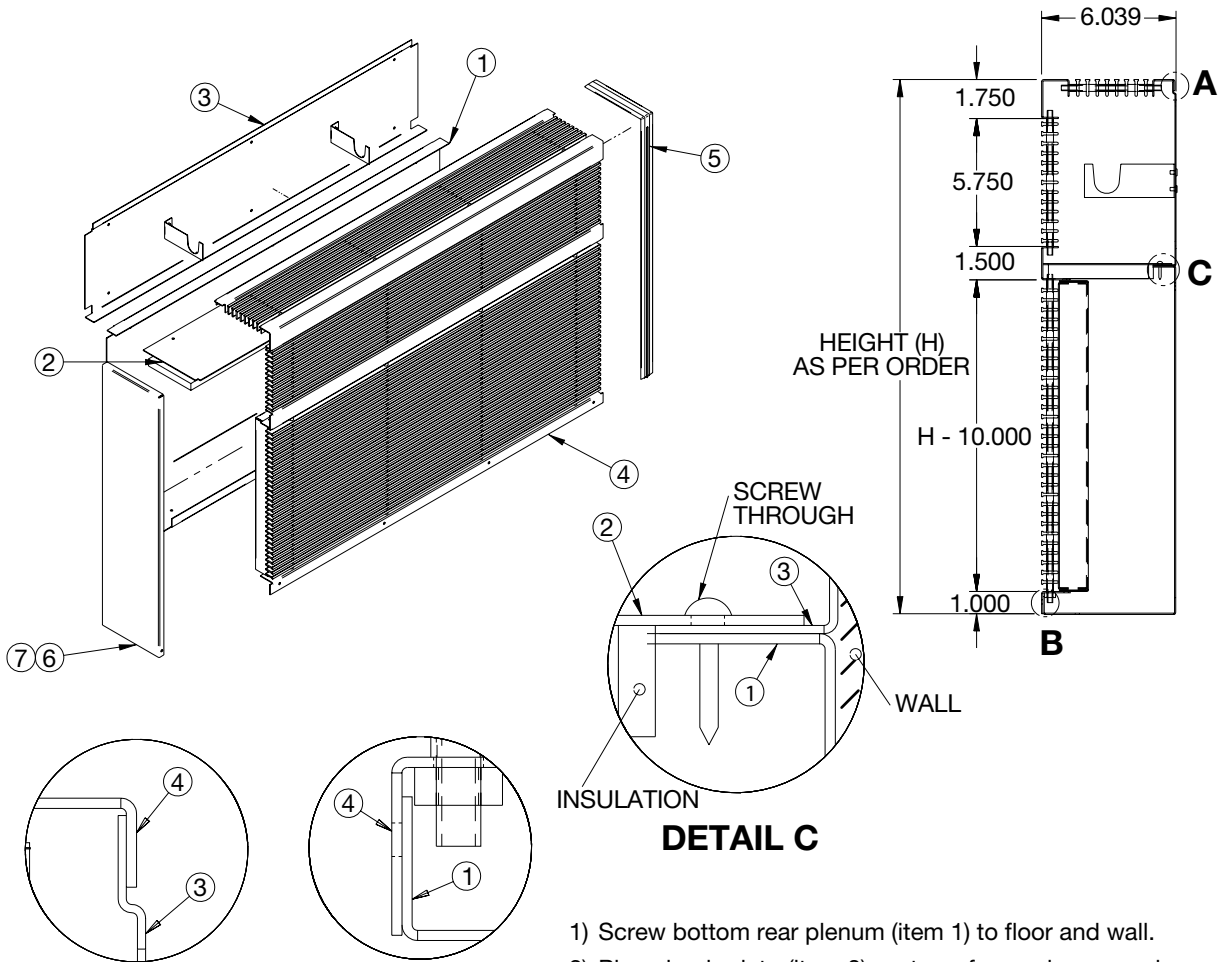

DETAIL A

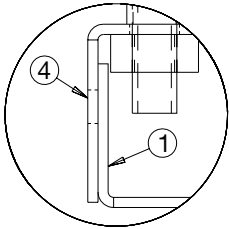

DETAIL B

DETAIL C

NOTE: FASTENERS (SUPPLIED BY OTHERS) TO BE SELECTED AS APPROPRIATE FOR WALL/FLOOR CONSTRUCTION TYPE

ITEM #	DESCRIPTION
1	BOTTOM REAR PLENUM x 1
2	DIVIDER x 1
3	BACK PLATE x 1
4	FRONT PANEL ASSEMBLY x 1
5	MULLION x 1
6	END CAP LEFT x 1
7	END CAP RIGHT x 1

- 1) Screw bottom rear plenum (item 1) to floor and wall.
- 2) Place back plate (item 3) on top of rear plenum and screw to wall. Place divider (item 2), with insulation side down, on top of back plate and screw the three items together.
- 3) Heating element is installed at this point (Price supplied optional)
- 4) Fit front panel assembly to back panel ensuring back lip of front panel fits behind back plate (see detail A) and the front bottom angle sits flush with bottom rear plenum (see detail B). Screw front panel to bottom rear plenum. (item 1)
- 5) Fit mullion (item 5) onto required end of front panel (item 4). Slide end cap (item 6 or 7) into place where necessary.

READ INSTRUCTIONS COMPLETELY BEFORE STARTING

PRICE®



2975 Shawnee Ridge Court
 Suwanee, Georgia USA 30024
 Ph: 770.623.8050 Fax: 770.623.6404

- U.S. Head Office
- Price Technical Center
- Atlanta Manufacturing Facility



1290 Barrow Industrial Parkway
 Winder, Georgia USA 30680-5704

- Atlanta Manufacturing Facility



999 North Thornton Road
 Casa Grande, Arizona USA 85222-3809

- Price Technical Center West
- Phoenix Manufacturing Facility



638 Raleigh Street
 Winnipeg, Manitoba Canada R2K 3Z9
 Ph: 204.669.4220 Fax: 204.663.2715

- Canadian Head Office
- Price Research Center North
- International Sales Office
- Winnipeg Manufacturing Facility



130B Pippin Road
 Vaughan, Ontario Canada L4K 4X9

- Toronto Manufacturing Facility

Product Improvement is a continuing endeavour at Price. Therefore, specifications are subject to change without notice. Consult your Price Sales Representative for current specifications or more detailed information. Not all products may be available in all geographic areas.

All goods described in this brochure are warranted as described in the Limited Warranty shown at the web site www.price-hvac.com.

The Price catalog is available online at www.price-hvac.com

