



PRICE[®]

**FCHCB/FCHCP
FAN COILS
HORIZONTAL CONCEALED
INSTALLATION MANUAL**



Date: 04/09
Reference #: F1-10

www.price-hvac.com

Contents

Safety Precautions	4
General	4
Caution to Contractors	4
Receiving Inspection	4
Control Assembly Label	5
Product Label	5
Submittal Sheets	6-7
Installation	
General	8
Mounting the Unit	8
Electrical Connection.....	8
Cooling/Heating Pipe Connections.....	8
Start Up & Operation	
General	9
Cooling/Heating	9
Air System Balancing	9
Motor & Fan Data	10
Water System Balancing	10
Filters	10
Maintenance	
Fan and Motor.....	11
Coils	11
Filters	11
Troubleshooting Guide.....	11
Replacement Parts List	12
Installation Checklist.....	13

Safety Precautions

- A. Installation work and electrical wiring must be done by qualified person(s) in accordance with all applicable codes and standards, including fire-rated construction.
- B. When cutting or drilling into wall or ceiling, do not damage electrical wiring and other hidden utilities.
- C. Use this unit only in the manner intended by the manufacturer. If you have any questions, contact the manufacturer:

in the United States PRICE INDUSTRIES 2975 Shawnee Ridge Court Suwanee, Georgia USA 30024 (770) 623-8050 Fax (770) 663-6404	in Canada E.H. PRICE LIMITED 638 Raleigh Street Winnipeg, Manitoba Canada R2K 3Z9 (204) 669-4220 Fax (204) 663-2715	International Export Sales Office E.H. PRICE LIMITED 638 Raleigh Street Winnipeg, Manitoba Canada R2K 3Z9 (204) 669-4220 Fax (204) 663-9810
---	---	---
- D. Before servicing or cleaning unit, switch power off at service panel and lock service panel to prevent power from being switched on accidentally.
- E. Protect flammable materials nearby when brazing, Use flame and heat protection barriers where needed. Always have a fire extinguisher ready.
- F. The manufacturer assumes no responsibility for personal injury or property damage resulting from improper handling, installation, service or operation of the product.

General

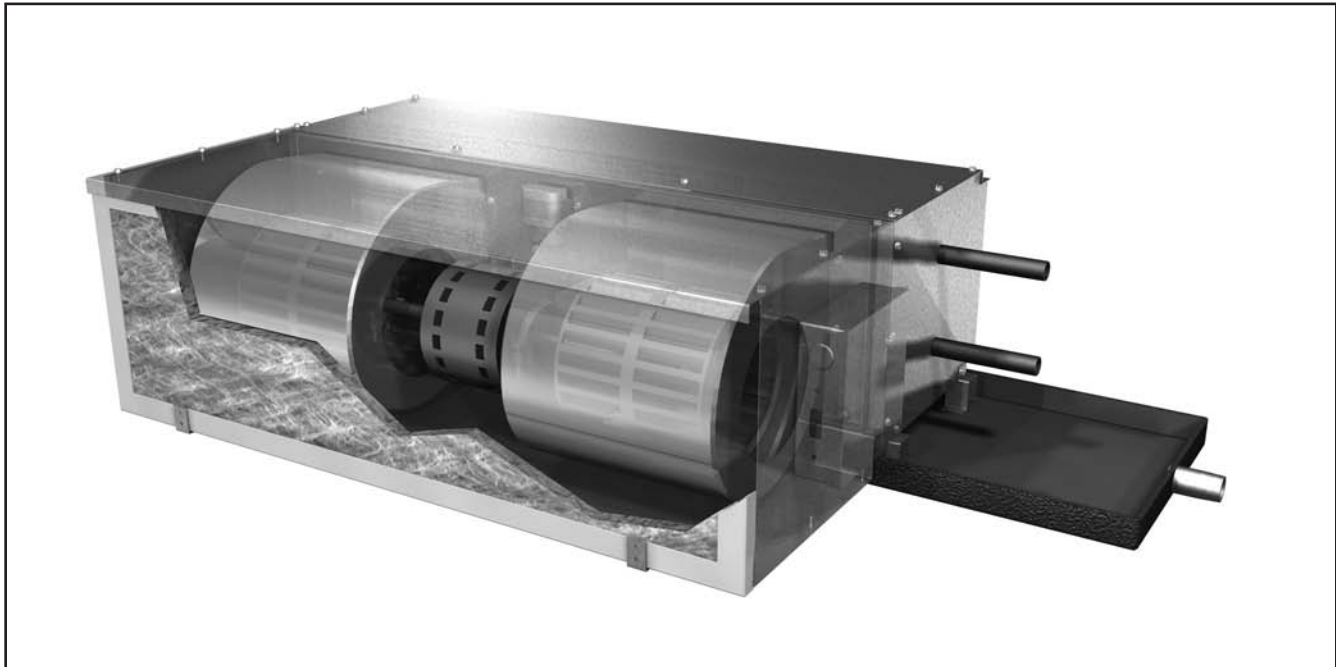

Caution to Contractors

Fan coil units are not intended for use as temporary heat or ventilation sources during building construction. The coil units are not designed nor equipped to operate in a dusty construction environment. Recirculating fan wheels can become coated in construction dust, resulting in an unbalanced wheel. This in turn can contribute to reduced motor life. Inlet air filters, if supplied, would provide little protection as they would quickly become plugged with construction dust.

Receiving Inspection

All Price fan coil units are inspected before shipment. After unpacking the assembly, check it for damage. If any damage to the products is found, report it immediately to the delivery carrier. Caution is required when unpacking the fan units with electric coils as not to damage the elements. Ensure that all packing material is removed from the inside of the unit, especially around the blower wheel and coil section.

Control Assembly Label

	VAV SPECIFICATIONS / SPÉCIFICATIONS VAV																													
	Price Order No / No Comm de Price:	54399																												
2975 Shawnee Ridge Court Suwanee, GA 30024 Phone: (770) 623-8050 Fax: (770) 623-6404	Branch PO / BC de la Succ:	T1002005																												
	Customer PO / BC du Client:	3429																												
	Job Name / Nom du Projet:	Commerce Trust																												
	Package Tag / Étiquette du Colis:																													
	Unit Location / Localisation de l'Unité:	FCU-25																												
AIR FLOW / DIRECTION DE L'AIR 	INSTALLED / INSTALLÉ: 	AIR DISTRIBUTION PRODUCTS / PRODUITS DE DISTRIBUTION D'AIR Manufactured By / Fabriqué Par Price 2975 Shawnee Ridge Court Suwanee, GA 30024 USA																												
Special Instructions / Instructions Spéciales: _____ _____ _____ _____																														
<table border="1"> <thead> <tr> <th>Item</th> <th>Model / Modèle</th> <th>Size / Grandeur</th> <th>Controller / Régulateur</th> <th>Motor / Moteur</th> </tr> </thead> <tbody> <tr> <td>1</td> <td>FCHCB</td> <td>03</td> <td></td> <td>EHP</td> </tr> <tr> <td colspan="2">Air Volume (cfm / l/s) / Volume d'Air (pcm / l/s)</td> <td>Reset Span / Plage d'Opération</td> <td>Damper / Volet</td> <td>Thermostat Coil Serpentin</td> <td>Application</td> </tr> <tr> <td>Min.</td> <td>Max.</td> <td></td> <td></td> <td></td> <td>Heating Cooling</td> </tr> <tr> <td></td> <td>Nom. 600 cfm</td> <td></td> <td></td> <td></td> <td></td> </tr> </tbody> </table>			Item	Model / Modèle	Size / Grandeur	Controller / Régulateur	Motor / Moteur	1	FCHCB	03		EHP	Air Volume (cfm / l/s) / Volume d'Air (pcm / l/s)		Reset Span / Plage d'Opération	Damper / Volet	Thermostat Coil Serpentin	Application	Min.	Max.				Heating Cooling		Nom. 600 cfm				
Item	Model / Modèle	Size / Grandeur	Controller / Régulateur	Motor / Moteur																										
1	FCHCB	03		EHP																										
Air Volume (cfm / l/s) / Volume d'Air (pcm / l/s)		Reset Span / Plage d'Opération	Damper / Volet	Thermostat Coil Serpentin	Application																									
Min.	Max.				Heating Cooling																									
	Nom. 600 cfm																													
031600																														

Product Label

<p>Manufactured By</p>	
MEETS UL1995 & CSA C22.2 NO. 236 <input checked="" type="checkbox"/> PRICE INDUSTRIES INC. Suwanee, Ga. USA <input type="checkbox"/> E.H.PRICE LIMITED Winnipeg, Mb. CANADA	
MODEL FCHCB/03	SERIAL 102159006001
H.P. 1/30	VOLTS/PH/CYC 115/1/60
MIN CIRCUIT AMPACITY (MCA) 0.875	AMPS 0.7
MAX OVERCURRENT PROT. (MOP) 1.5	R.P.M. 1075
MIN OPERATING STATIC PRESSURE IS 0.1 – 0.2 W.G.	MOTOR THERMALLY PROTECTED
UNIT SUITABLE FOR ZERO CLEARANCE SPACING TO COMBUSTABLE SURFACES, SEE INSTRUCTION SHEETS FOR AIR VOLUMES AND OTHER INFORMATION PERTINENT TO PROPER UNIT INSTALLATION.	
CAUTION: Disconnect The Remote Electric Power Supply Or Supplies Before Servicing. ATTENTION: Débrancher Le Block D'alimentation Installe A Distance Avant D'entreprendre Le Dépannage.	
045451-002	

Submittal Sheet

SIZE	NOMINAL		A in. (mm)	B in. (mm)	# OF BLOWERS	MOTORS (HP)	TOTAL AMPS		
	CFM	l/s					115V	208/240V	277V
02	200	94	16.0 (406)	30.1 (765)	1	1/30	0.7	0.5	0.5
03	300	142	25.0 (635)	39.4 (1001)	1	1/30	0.7	0.5	0.5
06	600	283	30.0 (762)	44.1 (1120)	2	1/10	1.8	0.7	0.64
08	800	378	40.0 (1016)	54.1 (1374)	2	1/10	1.8	0.7	0.64
10	1000	472	50.0 (1270)	64.1 (1620)	3	1/10, 1/30	2.5	1.2	1.14
12	1200	566	60.0 (1524)	73.8 (1875)	4	1/10, 1/10	3.6	1.4	1.28

NOTE:
TOTAL UNIT AMPS SHOWN
ARE BASED ON MOTOR
NAMEPLATE DATA.
ACTUAL PERFORMANCE
WILL VARY WITH THE
APPLICATION



PIPE SYSTEM	C in.(mm)	D in.(mm)	E in.(mm)
1 OR 2 ROW 2 PIPE	13.9 (353)	20 (508)	24.4 (620)
3 OR 4 ROW 2 PIPE	18.9 (480)	25 (635)	29.4 (747)
4 PIPE	22.5 (571)	28.6 (726)	33 (838)

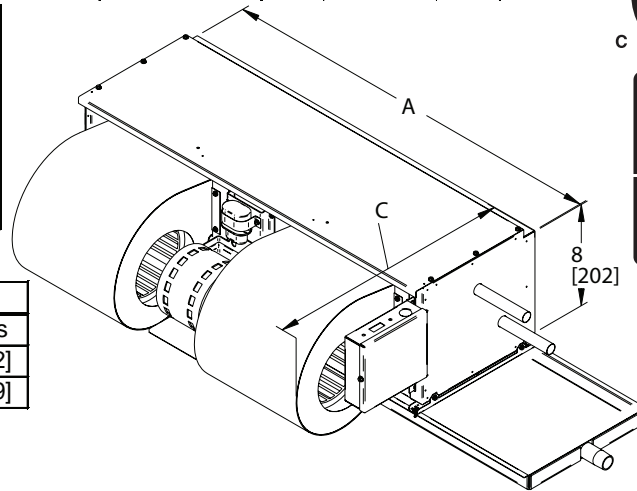

COIL CONNECTION SIZES				
	1 Row	2 Rows	3 Rows	4 Rows
O.D.	5/8" [16]	5/8" [16]	7/8" [22]	7/8" [22]
Nom.	1/2" [13]	1/2" [13]	3/4" [19]	3/4" [19]

O.D. = Outside Dimeter
Nom. = Nominal Pipe Size

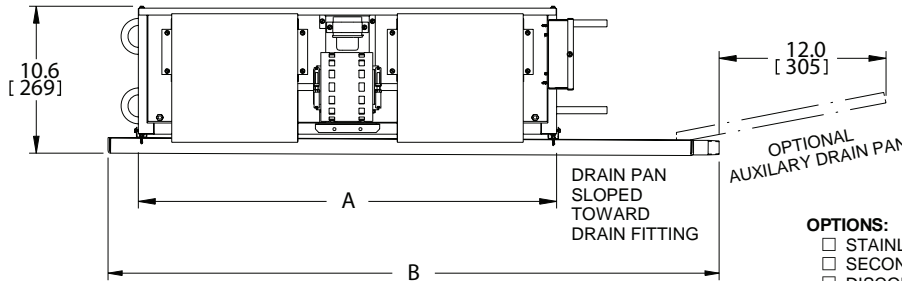

STANDARD CONSTRUCTION:

- 20ga. GALVANIZED STEEL CASING
- GALVANIZED HARDWARE
- COOLING COIL EQUIPPED WITH PAINTED DRAIN PAN EXTERNALLY INSULATED WITH FOAM
- 3/4" NPT DRAIN CONNECTION
- PSC ELECTRIC MOTORS WITH 3 SPEEDS
- COILS - 1/2" O.D. COPPER TUBES, ALUMINUM SINE WAVE FINS

OPTIONS:

- STAINLESS STEEL INSULATED DRAIN PAN
 - SECONDARY DRAIN
 - DISCONNECT SWITCH
 - MOTOR FUSE
 - THERMOSTAT - SHIPPED LOOSE
 - 115V/50-60Hz/1PH MOTOR WITH 3 SPEEDS
 - 208-240V/50-60Hz/1PH MOTOR WITH 3 SPEEDS
 - 277V/60Hz/1PH MOTOR WITH 3 SPEEDS
 - HANGER BRACKETS
 - AUXILIARY DRAIN PAN
- 2 PIPE SYSTEM**
- 1 - ROW 2 - ROW 3 - ROW 4 - ROW
- 4 PIPE SYSTEM**
- W/ PREHEAT (HEATING/COOLING)
- 1/3 - ROW 2/3 - ROW 1/4 - ROW 2/4 - ROW
- W/ REHEAT (COOLING/HEATING)
- 3/1 - ROW 3/2 - ROW 4/1 - ROW 4/2 - ROW

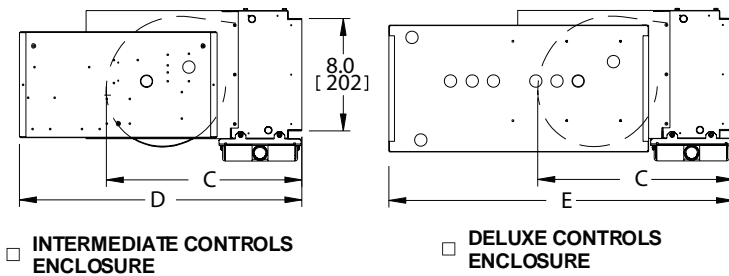

ALL METRIC DIMENSIONS () ARE SOFT CONVERTED. IMPERIAL DIMENSIONS ARE CONVERTED TO METRIC AND ROUNDED TO THE NEAREST MILLIMETER.

PROJECT:	price [®]	
ENGINEER:		
CUSTOMER:	JP	FAN COIL FC - H - C - B
SUBMITTAL DATE:	246798	HORIZONTAL CONCEALED W/OUT PLENUM
SPEC. SYMBOL:	2009/04/29	SIZE 02-12

Submittal Sheet

SIZE	NOMINAL		A in. (mm)	B in. (mm)	# OF BLOWERS	MOTORS (HP)	TOTAL AMPS		
	CFM	l/s					115V	208/240V	277V
02	200	94	16.0 (406)	30.1 (765)	1	1/30	0.7	0.5	0.5
03	300	142	25.0 (635)	39.4 (1001)	1	1/30	0.7	0.5	0.5
06	600	283	30.0 (762)	44.1 (1120)	2	1/10	1.8	0.7	0.64
08	800	378	40.0 (1016)	54.1 (1374)	2	1/10	1.8	0.7	0.64
10	1000	472	50.0 (1270)	64.1 (1620)	3	1/10, 1/30	2.5	1.2	1.14
12	1200	566	60.0 (1524)	73.8 (1875)	4	1/10, 1/10	3.6	1.4	1.28

NOTE:
TOTAL UNIT AMPS SHOWN
ARE BASED ON MOTOR
NAMEPLATE DATA.
ACTUAL PERFORMANCE
WILL VARY WITH THE
APPLICATION



PIPE SYSTEM	C in.(mm)	D in.(mm)	E in.(mm)
1 OR 2 ROW 2 PIPE	16.2 (412)	20 (508)	24.6 (625)
3 OR 4 ROW 2 PIPE	21.2 (539)	25 (635)	29.6(752)
4 PIPE	24.8 (630)	28.6 (726)	33.2 (843)

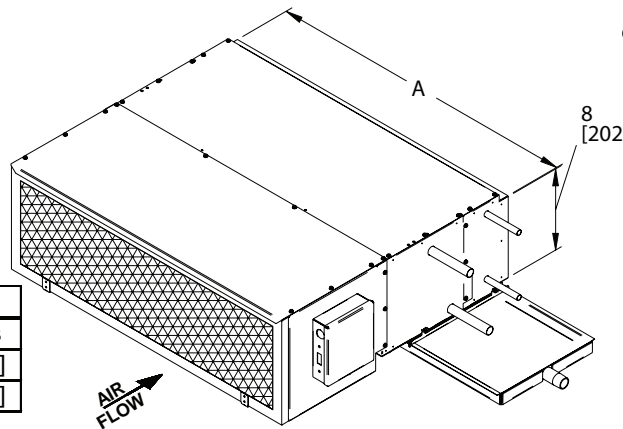

COIL CONNECTION SIZES				
	1 Row	2 Rows	3 Rows	4 Rows
O.D.	5/8" [16]	5/8" [16]	7/8" [22]	7/8" [22]
Nom.	1/2" [13]	1/2" [13]	3/4" [19]	3/4" [19]

O.D. = Outside Dimeter
Nom. = Nominal Pipe Size

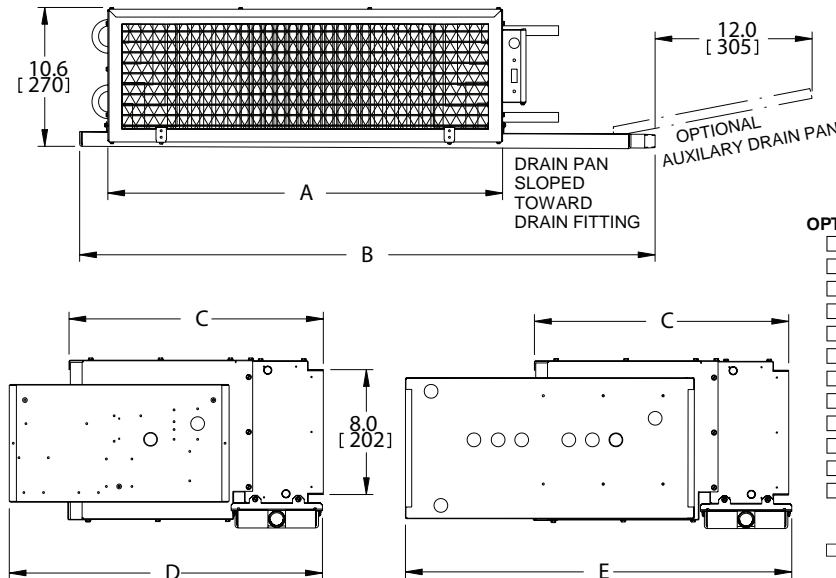

STANDARD CONSTRUCTION:

- 20ga. GALVANIZED STEEL CASING
- GALVANIZED HARDWARE
- COOLING COIL EQUIPPED WITH PAINTED DRAIN PAN EXTERNALLY INSULATED WITH FOAM
- 3/4" NPT DRAIN CONNECTION
- PSC ELECTRIC MOTORS WITH 3 SPEEDS
- COILS - 1/2" O.D. COPPER TUBES, ALUMINUM SINE WAVE FINS
- 1" THICK THROWAWAY FILTER WITH FIBERGLASS MESH MEDIA
- INTERNAL INSULATION - FIBERGLASS 1/2" (13mm) THICK

OPTIONS:

- STAINLESS STEEL INSULATED DRAIN PAN
 - SECONDARY DRAIN
 - DISCONNECT SWITCH
 - MOTOR FUSE
 - 115V 50-60Hz/1PH MOTOR WITH 3 SPEED
 - 208-240V/50-60Hz/1PH MOTOR WITH 3 SPEED
 - 277V/60Hz/1PH MOTOR WITH 3 SPEED
 - HANGER BRACKETS
 - THERMOSTAT - SHIPPED LOOSE
 - FF50 (FIBERFREE), LINER 1/2" THICK
 - FB FOIL FACED FIBERGLASS LINER 5/8" THICK
 - AUXILIARY DRAIN PAN
- 2 PIPE SYSTEM**
- 1 - ROW 2 - ROW 3 - ROW 4 - ROW
- 4 PIPE SYSTEM**
- W/ PREHEAT (HEATING/COOLING)
- 1/3 - ROW 2/3 - ROW 1/4 - ROW 2/4 - ROW
- W/ REHEAT (COOLING/HEATING)
- 3/1 - ROW 3/2 - ROW 4/1 - ROW 4/2 - ROW

ALL METRIC DIMENSIONS () ARE SOFT CONVERTED. IMPERIAL DIMENSIONS ARE CONVERTED TO METRIC AND ROUNDED TO THE NEAREST MILLIMETER.

PROJECT:		
ENGINEER:		
CUSTOMER:	JP	FAN COIL FC - H - C - P HORIZONTAL CONCEALED WITH PLENUM SIZE 02-12
SUBMITTAL DATE:	243642	
SPEC. SYMBOL:	2009/04/28	REV F

Installation

General

Price fan coils are designed to be durable and manufactured for sturdy construction. The units must still be handled with great care and no force or pressure applied to the coil or piping. When handled, the unit should be carried in an upright position holding onto the mounting points. The fan coils are not suitable for outdoor installations. The units should never be stored or installed where it may be subjected to a hostile environment such as rain, snow, or extreme temperatures. Care must be taken during and after installation to prevent foreign material such as paint, drywall mud or dust from entering the drain pan or the motor or blower wheels. Failure to do so may have serious effects on the unit performance and may cause premature failure if foreign material is allowed to be deposited into the motor or blower. Some job conditions may require the unit to be covered temporarily until installation

WARNING: Do not tamper with control components.

Mounting the Unit

Use trapeze hangers or optional factory mounted hanger brackets as illustrated. Hanging rods should be securely attached to joists or to mounting anchors which are properly secured to slab construction with lugs or poured in place anchors. Price Fan Coil Units are designed to be mounted in the direction indicated by the Control Assembly Label found on the protective shroud. Adequate clearance must be provided for the fan coil for service and the removal of the internal equipment. Correct installation of the trapeze bars will not block access for service. See figure below for recommended mounting locations for hanger brackets. Do not install tight to slab, avoid contact with other obstacles such as rigid conduit and sprinkler piping. This can cause excessive vibration and noise transmission. Care must be taken to ensure that the unit drain pan does not slope away from the outlet connection. The drain pan is sloped toward the outlet connection when the unit is installed level and plumb. Ensure main power to the unit has been disconnected prior to performing any electrical work or inspection of the circuitry.

Electrical Connection

CAUTION: Disconnect all incoming power before any electrical installation or service is performed on the unit(s). All field wiring is to be in accordance with the National Electrical Code ANSI/NFPA No. 70 or the Canadian Electrical Code, Part 1, CSA Standard C 22.1. Refer to the product identification label on each unit for information to determine the field wire size. Check voltage requirements prior to power supply connection. Refer to the electrical label located near the electrical control box and also refer to the schematic drawing provided on the underside of the electrical control box cover. If upon energizing the electric motor excessive noise is apparent, shut down the unit. Determine the cause by checking for packing materials, etc. and re-energize after corrective action has been taken.



Screw Installation



Auxiliary Drain Pan Positioning

Auxiliary Drain Pan Mounting

Auxiliary drain pan is mounted inside the attached drain pan. Align the mounting holes and install the screw from the inside out, see figure above. Once the screws are installed ensure drain pan is in proper position leaning down against the attached drain pan. See figure above for proper positioning.



Optional Hanger Brackets

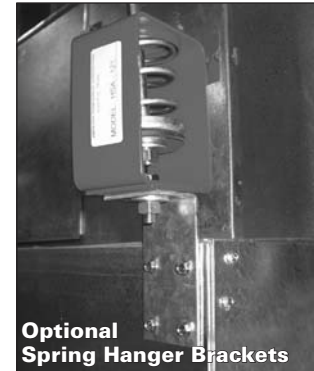
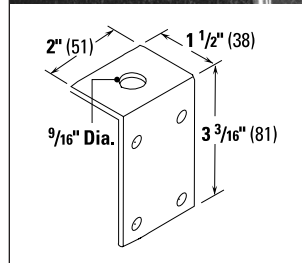

Optional Spring Hanger Brackets

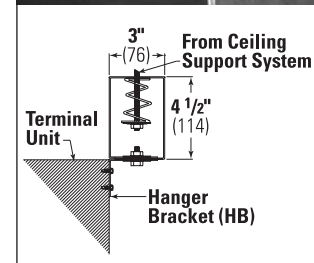

Cooling/Heating Pipe Connections

The valve packages are easily damaged when introduced to excessive amounts of heat. Great caution must be made when the connections are made with "sweat" or solder joints. The valve must be in the open position during all soldering and brazing operations. Heat should be dissipated with a wet cloth wrapped around the valve body.

Automatic valves must have the control cartridge removed for soldering.

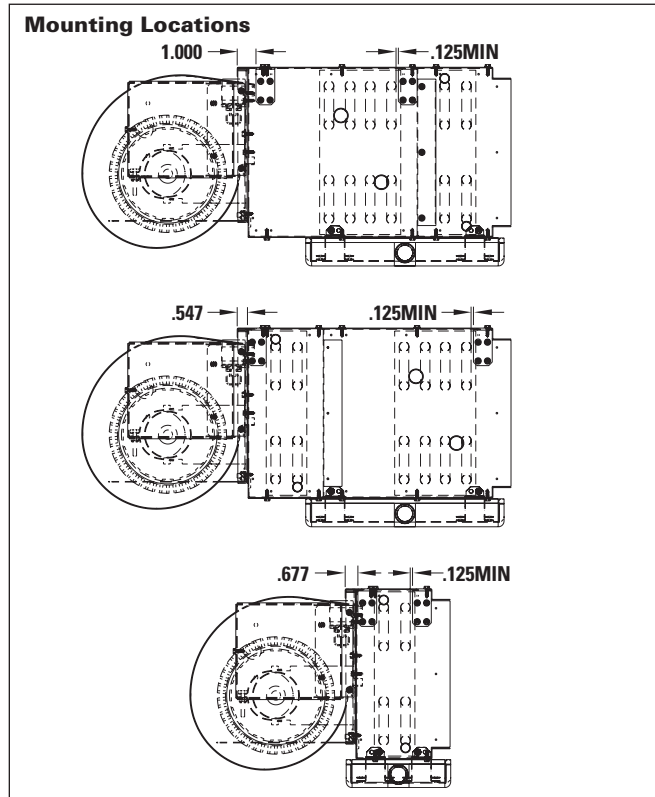

Start Up & Operation

General

Before beginning start up operation, familiarize yourself with the unit, options, accessories, controls so you understand proper system operation. All personnel should have a good working knowledge of general start-up procedures and have the appropriate start-up and balancing guides available for consultation.

For standard (PSC) motors a minimum of 0.1"W.G. downstream static pressure is required to prevent overheating of the fan motor. Overheating of the fan motor can cause the unit to trip the thermal overload and reduce motor life.

Cooling/Heating

Prior to the water system start-up and balancing, the chilled/hot water systems should be flushed to clean out dirt and debris, which may have collected in the piping during construction. During this procedure, all unit service valves must be in the closed position. This prevents foreign matter from entering the unit and clogging the valves and metering devices. Filters should be installed in the piping mains to prevent this material from entering the units during normal operation. During system filling, air venting from the unit is accomplished by the use of the standard manual air vent fitting installed on the coil. Manual air vent fitting, the screw should be turned counterclockwise no more than 1-½ turns to operate the air vent.

CAUTION: The air vent provided on the unit is not intended to replace the main system air vents and may not release air trapped in other parts of the system. Inspect the entire system for potential air traps and vent those areas as required, independently. In addition, some systems may require repeated venting over a period of time to properly eliminate air from the system.

Air System Balancing

All duct-work must be complete and connected, and all grilles, filters, access doors and panels must be properly installed to establish actual system operating conditions BEFORE beginning air balancing operations. Each individual unit and attached duct-work is a unique system with its own operating characteristics. For this reason, air balancing is normally done by balance specialists who are familiar with all procedures required to properly establish air distribution and fan system operating conditions. These procedures should not be attempted by unqualified personnel. After the proper system operation is established, the actual unit air delivery and the actual fan motor amperage draw for each unit should be recorded in a convenient place for future reference such as the inspection, installation, & start-up check sheet, a copy of which is provided on the back of this manual. Contact the Sales Representative or the factory for additional copies of this sheet.

The manufacturer assumes no responsibility for undesirable system operation due to improper design, equipment or component selection, and/or installation of ductwork, grilles, and other field supplied components.

Motor & Fan Data

Unit Size	Fan Speed	Motor HP(s)	# of Fans	115 Volts		277 Volts	
				Amps	Watts	Amps	Watts
02	High	1/30	1	0.63	70	0.48	94
	Medium			0.48	53	0.27	65
	Low			0.38	41	0.19	48
03	High	1/30	1	0.67	75	0.5	103
	Medium			0.5	55	0.28	71
	Low			0.37	40	0.18	48
06	High	1/10	2	1.66	166	0.63	170
	Medium			1.17	118	0.37	100
	Low			0.82	81	0.24	65
08	High	1/10	2	1.74	177	0.66	176
	Medium			1.16	118	0.39	106
	Low			0.79	80	0.25	66
10	High	1/30 & 1/10	3	2.36	250	0.96	240
	Medium			1.69	177	0.45	118
	Low			1.24	127	0.29	76
12	High	1/10 & 1/10	4	3.28	330	1.22	330
	Medium			2.29	230	0.75	205
	Low			1.65	162	0.48	130

Notes:

- Based on 3 row dry coil and 0.0 ESP. Nameplate values for amperage may be higher.

Water System Balancing

A complete knowledge of the hydronic system, its components, and controls is essential to proper water system balancing and this procedure should not be attempted by unqualified personnel. The system must be complete and all components must be in operating condition BEFORE beginning water system balancing operations. Each hydronic system has different operating characteristics depending on the devices and controls in the system. The actual balancing technique may vary from one system to another. After the proper system operation is established, the appropriate system operating conditions such as various water temperatures and flow rates should be recorded in a convenient place for future reference. Before and during water system balancing, conditions may exist which can result in noticeable water noise or undesired valve operation due to incorrect system pressures. After the entire system is balanced, these conditions will not exist on properly designed systems.

Filters

The type of throwaway filter most commonly used on fan coil units should be replaced on a regular basis. The time interval between each replacement should be established based on regular inspection of the filter and should be recorded in the log for each unit. Refer to the chart below for recommended filter size for each product type and size. If the replacement filters are not purchased from the factory, the filters used should be the same type and size as that furnished from or recommended by the factory. Pleated media or extended surface filters should not be used since the high air pressure drops encountered with these types of filters is not compatible with the type of fan coil unit covered in this manual. Consult the factory for applications using filter types other than the factory standard or optional product.

Unit Size	Filter Face Area	Nominal Filter Sizes
02	1.11	10 x 16
03	1.74	10 x 25
06	2.08	10 x 30
08	2.78	10 x 40
10	3.47	10 x 50
12	4.17	10 x 60

Maintenance

Fan and Motor

1. Disconnect all incoming power before servicing the unit.
2. Price fan coil units are supplied with permanently lubricated motors.
3. The blower and motor should be inspected annually for accumulation of dust and dirt. Clean as necessary.
4. Blower and motor for can be accessed without disconnecting ductwork.

CAUTION: MOTOR MAY BE VERY HOT. ENSURE MOTOR HAS COOLED BEFORE SERVICE.

5. Motors are provided with thermal overload protection. If the motor overheats and trips the thermal overload, it will automatically reset after cooling down to a proper operating temperature.

Coils

1. Disconnect all incoming power before servicing the unit.
2. To access coils for servicing, remove blower and motor assemblies.
3. The coil should be inspected periodically for accumulation of dust and dirt. Clean as necessary. Cleaning can be done by brushing the coils in the direction of the fins as to not damage them. Compressed air can also be used to blow out the dust particles in the coil. Vacuum up all dust particles so they can not damage the blower and motor.

Filter(s)

1. Filters, if supplied, should be replaced or removed after system start-up.
2. If filters are used beyond system start-up they should be changed regularly to avoid excessive restriction of air flow. Frequency would depend on environment.

Contact your Price representatives for details on replacement filter media.

Troubleshooting Guide

<p>General</p>	<ol style="list-style-type: none"> 1. Confirm fan coil size and rating with blueprint and schedule (check Control Assembly label on terminal unit). 2. Visually check electrical connections with the Control Wiring diagram(s) located inside the electrical enclosure or in the applicable controls brochure. 3. Verify that the supply voltage is the same as specified on the control diagram(s) or Voltage Information label.
<p>Noise</p>	<ol style="list-style-type: none"> 1. Foreign material in fan. 2. Fan or duct size selection too small for application causing high air velocity. 3. Vibrating duct work. 4. Unbalanced fan wheel causing it to hit the housing.
<p>Fan Does Not Operate</p>	<ol style="list-style-type: none"> 1. Check the unit wiring against the provided Control and Wiring diagrams. See inside cover of the electrical enclosure for diagrams. 2. Verify that the disconnect switch or breaker is not opened. 3. Check for proper control signal from thermostat. See thermostat for full heating and monitor output. 4. Fan wheel may be touching the housing.
<p>Air Volume not as Specified</p>	<ol style="list-style-type: none"> 1. Check filter for excessive dust build-up. 2. Check fan for particle blockage. 3. Check coils for particle blockage. 4. Measure downstream static pressure; compare to fan curve. 5. Verify that the supply voltage is the same as specified on the wiring diagram. See wiring diagram pasted on the inside of the electrical enclosure or in the applicable controls brochure. 6. Insulating duct liner loose.

Replacement Parts

Component	Part#	Description
Fan Motors	019142-001	115V - 1/10 HP (Sizes 06,08, 10 & 12)
	019142-002	208V-240V - 1/10 HP (Sizes 06, 08, 10 &12)
	019142-003	277V - 1/10 HP (Sizes 06, 08, 10 & 12)
	019145-001	115V - 1/30 HP (Sizes 02, 03 & 10)
	019145-002	208V-240V - 1/30 HP (Sizes 02,03 & 10)
	019145-003	277V - 1/30 HP (Sizes 02, 03 & 10)
Fan Speed Controllers	019432-001	3 Speed Controller
Blowers	100152-001	Left Hand Blower
	100152-002	Right Hand Blower
Coils	02357-001	1 Row Coil (Size 02)
	02357-002	1 Row Coil (Size 03)
	02357-003	1 Row Coil (Size 06)
	02357-004	1 Row Coil (Size 08)
	02357-005	1 Row Coil (Size 10)
	02357-006	1 Row Coil (Size 12)
	023508-001	2 Row Coil (Size 02)
	023508-002	2 Row Coil (Size 03)
	023508-003	2 Row Coil (Size 06)
	023508-004	2 Row Coil (Size 08)
	023508-005	2 Row Coil (Size 10)
	023508-006	2 Row Coil (Size 12)
	023509-001	3 Row Coil - Right (Size 02)
	023509-002	3 Row Coil - Right (Size 03)
	023509-003	3 Row Coil - Right (Size 06)
	023509-004	3 Row Coil - Right (Size 08)
	023509-005	3 Row Coil - Right (Size 10)
	023509-006	3 Row Coil - Right (Size 12)
	023509-011	3 Row Coil - Left (Size 02)
	023509-012	3 Row Coil - Left (Size 03)
	023509-013	3 Row Coil - Left (Size 06)
	023509-014	3 Row Coil - Left (Size 08)
	023509-015	3 Row Coil - Left (Size 10)
	023509-016	3 Row Coil - Left (Size 12)
	023512-001	4 Row Coil - Right (Size 02)
	023512-002	4 Row Coil - Right (Size 03)
	023512-003	4 Row Coil - Right (Size 06)
	023512-004	4 Row Coil - Right (Size 08)
	023512-005	4 Row Coil - Right (Size 10)
	023512-006	4 Row Coil - Right (Size 12)
	023512-011	4 Row Coil - Left (Size 02)
	023512-012	4 Row Coil - Left (Size 03)
	023512-013	4 Row Coil - Left (Size 06)
	023512-014	4 Row Coil - Left (Size 08)
023512-015	4 Row Coil - Left (Size 10)	
023512-016	4 Row Coil - Left (Size 12)	
Filters	042297-032	1" Glass Fiber Filter (Size 02)
	042297-033	1" Glass Fiber Filter (Size 03)
	042297-034	1" Glass Fiber Filter (Size 06)
	042297-035	1" Glass Fiber Filter (Size 08)
	042297-036	1" Glass Fiber Filter (Size 10)
	042297-037	1" Glass Fiber Filter (Size 12)
Disconnect Switch	019903-001	115V/277V Single Pole
Fuse Block	019459-001	Fuse Block 600V 30A
Motor Fuse	019124-003	115V - 4A (Sizes 06 & 08)
	019124-004	208V-240V/277V - 2A (Sizes 10 &12)
	019124-007	115V - 4.5A (Size 10)
	019124-008	115V - 5A (Size 12)
	019124-020	115V/208V-240V/277V- 1A (Sizes 02, 03, 06 & 08)
	019124-021	115V/208V-240V/277V- 1.5A (Sizes 02, 03, 06, 08 & 12)

Installation Checklist

Receiving & Inspection

- Unit Received Undamaged
- All Parts Accounted For
- Unit Arrangement/Hand Correct

Handing and Installation

- Unit mounted Level and Plumb
- Correct Electrical Service
- Proper Access Available for Unit and Components
- Correct Overcurrent Protection Provided
- Rubber Grommet Isolators Used
- Correct Service Switch/Disconnect Provided
- Correct Chilled Water Line to the Unit
- Correct Hot Water Line to the Unit
- Code Compliance for All Components
- Shipping Screws and Hardware Removed
- Unit Protected from Dirt and Foreign Matter

Cooling/Heating Connections

- Unit mounted Level and Plumb
- Correct Electrical Service
- Proper Access Available for Unit and Components
- Correct Overcurrent Protection Provided
- Rubber Grommet Isolators Used
- Correct Service Switch/Disconnect Provided
- Correct Chilled Water Line to the Unit
- Correct Hot Water Line to the Unit
- Code Compliance for All Components
- Shipping Screws and Hardware Removed

Ductwork Connections

- Correct Supply and Return Grille type and Size
- Flexible Duct Connections to Unit
- Insulate ductwork as required
- Control Outside Air to Protect from Heat/Cold

Electrical Connections

- Refer to Unit Wiring Diagram
- Wiring in Code Compliance
- Connect Power Service

Unit Startup

- Unit mounted Level and Plumb
- Correct Electrical Service
- Proper Access Available for Unit and Components
- Correct Overcurrent Protection Provided
- Rubber Grommet Isolators Used
- Correct Service Switch/Disconnect Provided
- Correct Chilled Water Line to the Unit
- Correct Hot Water Line to the Unit
- Code Compliance for All Components
- Shipping Screws and Hardware Removed



PRICE
INDUSTRIES

2975 Shawnee Ridge Court
Suwanee, Georgia USA 30024
Ph: 770.623.8050 Fax: 770.623.6404



PRICE
INDUSTRIES

1290 Barrow Industrial Parkway
Auburn, Georgia USA 30011



PRICE
INDUSTRIES

999 North Thornton Road
Casa Grande, Arizona USA 85222-3809



e.h. price
LIMITED

638 Raleigh Street
Winnipeg, Manitoba Canada R2K 3Z9
Ph: 204.669.4220 Fax: 204.663.2715

The founding principles of our company have never changed - business integrity, first class service and a commitment to people. Price manufacturing endeavors arose from our belief that we could supply superior products and services at a reasonable price. Our mission is to become the world-wide supplier of preference for air distribution products and services. You can rely on Price – our products and services – with confidence.

Warranty: The Company warrants and guarantees that all goods within this catalog that have been manufactured by the Company have been manufactured in accordance with the specifications published herein and will be free from defects in material and workmanship for a period of twelve (12) months from the date of Bill of Lading issued by the Company. The Company will replace defective product at its option, but will not be responsible for labor or material charges in replacing product or consequential damages. Any installation not conforming with the Company's specifications, manuals, bulletins or instructions or any misuse or any modification not authorized by the Company voids this warranty. This warranty is in lieu of all Provincial, State, and Federal statutory warranties and the conditions herein are in substitution and replacement of such warranties, statutory or otherwise.

Your Local Price Representative:

Grilles & Diffusers

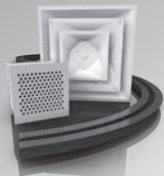

Critical Environments

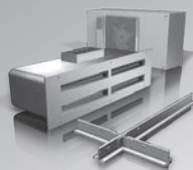

Terminals



Sustainable Building

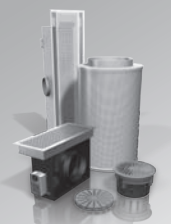

Noise Control

