

PRICE®

FAN POWERED LOW PROFILE VARIABLE VOLUME TERMINAL UNITS



Date: 04/11
Reference #: F-94

www.price-hvac.com

Contents

General	4
Control Assembly Label	5
Installation	6
Maintenance	7
Air Balancing Procedure	8
Operating Guidelines	8
Fan Performance Curves	9
Electronic Airflow Adjustment Procedures	11
Electronic Calibration Curves	13
Pneumatic Calibration Procedures	14
Pneumatic and Digital Calibration Curves	16
Troubleshooting Guide	17
Parts List	18

General

Price fan powered low profile terminals are available with pneumatic, electronic or direct digital (DDC) controls. In most cases pneumatic and electronic controls are factory supplied and mounted. In the case of DDC controls, the terminal unit controls are often supplied by the controls contractor and either factory or field mounted. For information concerning controls, components, sequence of operations, etc. for DDC controls supplied by the controls contractor, please refer to the documentation provided by the controls contractor.



Damper rotation is always clockwise to the open position. An identification mark on the end of the shaft indicates the damper position. Capped tees are provided in sensing lines from the amplifying sensor. These allow field connection of differential pressure gauge for accurate airflow measurement (not applicable with electronic controls).

An optional metal control cover may be provided to protect the terminal unit control components. The protective cover is removable with two sheet metal screws.

The velocity sensor is normally supplied as standard with the terminal unit. However, in some cases a flow-sensing device supplied by the controls contractor may be field or factory mounted. Refer to the submittal drawing for illustration.

Control Assembly Label



**VAV SPECIFICATIONS /
SPÉCIFICATIONS VAV**

Price Order No / No Comm de Price: 54399

Branch PO / BC de la Succ: T100200J

Customer PO / BC du Client: 3429

Job Name / Nom du Projet: Commerce Trust

Package Tag / Étiquette du Colis: _____

Unit Location / Localisation de l'Unité: VAV-59

**AIR FLOW /
DIRECTION DE L'AIR**



**INSTALLED /
INSTALLÉ:**



AIR DISTRIBUTION PRODUCTS /
PRODUITS DE DISTRIBUTION D'AIR

Manufactured By / Fabriqué Par
Price

Special Instructions / Instructions Spéciales: SCHEM #CX49210

Fan Flow = 250 cfm

Item	Model / Modèle	Size / Grandeur	Controller / Régulateur	Motor / Moteur
1	FPV8000	2008	CP101 Controller	EHP

Air Volume (cfm / l/s) / Volume d'Air (pcm / l/s)		Reset Span / Plage d'Opération	Damper / Volet	Thermostat	Coil Serpentin	Application
Min.	Max.					
0	500 cfm 236 L/s	8-13 psi	Norm, Open	Direct Acting		Cooling

031600

All Price fan powered low profile terminal units are tagged with a control assembly label as shown on the left. This label identifies the model number, location tag #, controller type, actuator type, thermostat action, damper action, application and controller set points. Options, accessories and appropriate control diagrams are also identified. If field adjustment of the controller set points should become necessary, follow the appropriate procedure outlined in this manual. Note that all pneumatic controls must be calibrated in the position they are mounted.

All factory-supplied controllers are tagged with a controller label as shown below. This label identifies the required sensor velocity pressure for both the minimum and maximum controller set points.

Price Order No. / No. de Comm. de Price	Item	Model / Modèle	Size / Grandeur	Unit Location / Localisation de L'Unité
54399	1	FPV8000	2008	VAV-59
Damper / Volet		Air Volume (cfm / l/s) / Volume d'air (pcm / l/s)		Reset Span / Plage d'Opération
Norm. Open		0 cfm 500 cfm 0 L/s 236 L/s	0,000 0,286" 0 71 Pa	8-13 psi

Caution To Contractors

1. Fan powered terminal units are not intended for use as temporary heat or ventilation sources during building construction. The terminal units are not designed nor equipped to operate in a dusty construction environment. Recirculating fan wheels can become coated in construction dust, resulting in an unbalanced wheel. This in turn can contribute to reduced motor life. Inlet air filters, if supplied, would provide little protection as they would quickly become plugged with construction dust.
2. A fan powered terminal unit should never be operated if the downstream duct work has not been installed. A minimum of 0.10 inches W.G. downstream static pressure resistance is required for safe operation of the fan motor. Units with electric heat require 0.20 inches W.G. for stable operation.

Please note that Price cannot warrant against unauthorized operating conditions as outlined above.

Receiving Inspection

All Price fan powered terminal units are inspected before shipment. After unpacking the assembly, check it for damage. If any damage to the products is found, report it immediately to the delivery carrier. During unpacking and installation, **do not handle the unit by the inlet velocity sensor**. Caution is required when unpacking the fan powered units with electric coils as not to damage the elements.

WARNING: DO NOT ADJUST THE CONTROL COMPONENTS

Installation

Mounting The Unit

1. Use trapeze hangers or optional factory mounted hanger brackets as illustrated. Hanging rods should be securely attached to joists or to mounting anchors, which are properly secured to slab construction with lugs, or poured in place anchors. Trapeze bars should be positioned within 3 inches (76 mm) of the discharge end and 2.5 inches (63 mm) of the inlet end to allow for access panel removal.
2. Price Fan Powered Low Profile Terminal Units are designed to be mounted in the direction indicated by the Control Assembly Label found on the protective shroud.
3. Do not block the bottom access panel - maintain clearance for blower service. Correct installation of the trapeze bars will not block access panel removal.
4. Do not install tight to slab, avoid contact with other obstacles such as rigid conduit and sprinkler piping. This can cause excessive vibration and noise transmission.
5. Install the unit in a location that allows free access to the unit as well as all control components.
6. Ensure main power to the terminal and electric coil has been disconnected prior to performing any electrical work or inspection of the circuitry.
7. **WARNING:** Do not tamper with control components.

Optional Hanger Brackets

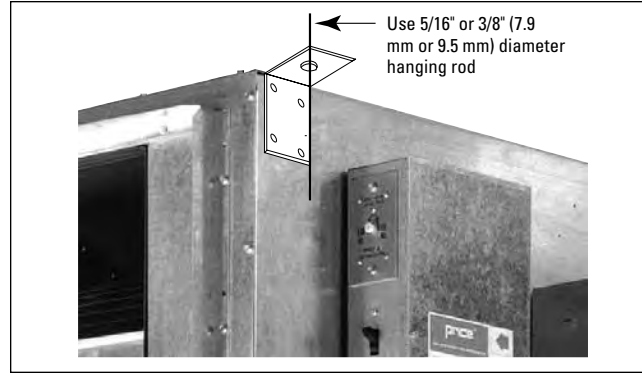

Trapeze Hangers

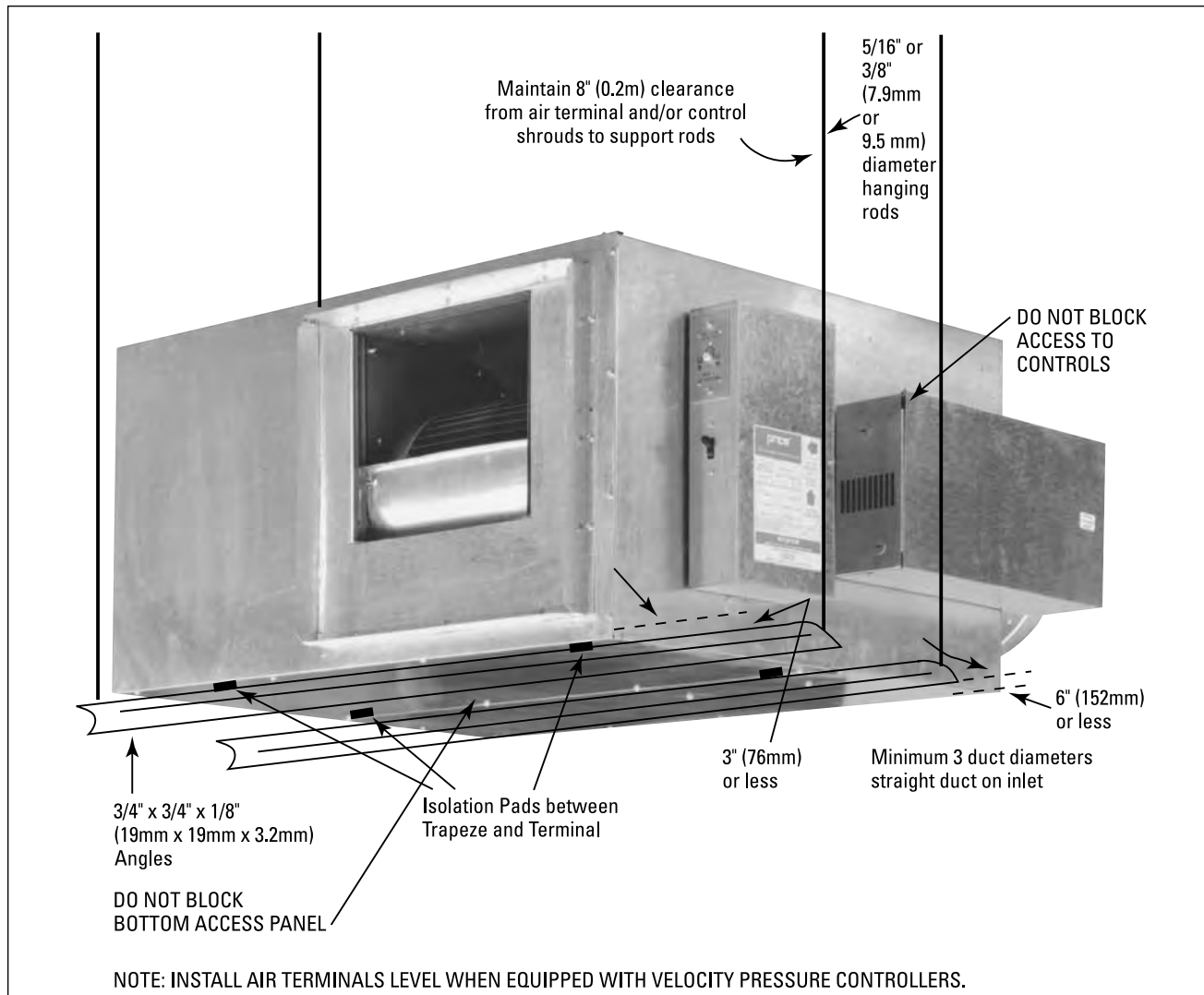

Duct Connection

1. Recommend a minimum of 3 duct diameters of straight inlet duct, either sheet metal or flexible, same size as the inlet, between the unit inlet and any transition, take-offs or fittings. Use of transitions or elbows at the unit inlet to be avoided. Where flexible duct is used it should be pulled tight to eliminate sags or folds.
2. To control radiated noise in critical applications, it is recommended that the inlet ducts be fabricated of minimum 24-gauge sheet metal in place of flexible ducts.
3. To prevent excessive air leakage, all cleat joints should be sealed with an approved duct sealer. This applies to all accessory connections as well as the basic fan powered low profile terminal unit.
4. Holes that are drilled in the duct for testing or balancing purposes are to be sealed with duct tape or duct sealer.
5. For motors a minimum of 0.1" W.G. downstream static pressure is required to prevent overheating of the fan motor. For units with electric heaters a minimum of 0.2" W.G. is required.

Electrical Connection

CAUTION: Disconnect all incoming power before any electrical installation or service is performed on the unit(s).

1. All field wiring is to be in accordance with the National Electrical Code ANSI/NFPA No.70 or the Canadian Electrical Code, Part 1, CSA Standard C22.1.
2. Refer to the product identification label on each unit for information to determine the field wire size.
3. Check voltage requirements prior to power supply connection. Refer to the electrical label located near the electrical control box and also refer to the schematic drawing provided on the underside of the electrical control box cover.
4. If, upon energizing the electric motor, excessive noise is apparent, shut down the unit. Determine the cause by checking for packing materials, etc. and re-energize after corrective action has been taken.
5. If an Electric Reheat Coil has been supplied, refer to the electrical schematic, which is permanently affixed to the underside of the electrical control cabinet door, prior to hook-up. Check the voltage requirements to ensure proper voltage supply is used.

Caution: For three phase power connections, be sure to account for fan motor load. Phases must be balanced accordingly.

Control Connections

Pneumatic

1. External control air connections are provided for main air and thermostat hook-up. These are to be piped according to the label on the control shroud.
2. Main air supply must be clean and dry, delivered at 15 to 25 psi (maximum 25 psi).
3. Ensure that lines are not crimped or cut when installed.

Electronic

A wiring diagram is provided with each assembly. Follow the diagram for wiring of the thermostat and other accessories.

Digital

If controls have been factory mounted, a wiring diagram will be included with the unit indicating the factory-mounted components. For field wiring of room sensors and other accessories, refer to the controls contractor's documentation for all wiring information.

Maintenance

Fan and Motor

1. Disconnect all incoming power before servicing the unit.
2. Price fan powered low profile terminal units are supplied with permanently lubricated motors.
3. The blower and motor should be inspected annually for accumulation of dust and dirt. Clean as necessary.
4. To access blower and motor for servicing, remove the side access panel.

CAUTION: Motor may be very hot. Ensure motor has cooled before service.

5. Motors are provided with thermal overload protection. If the motor overheats and trips the thermal overload, it will automatically reset after cooling down to a proper operating temperature.
6. If field amperage draw readings of the fan motor are required, measurements should be taken with a true RMS meter. Non-true RMS meters will not provide accurate readings due to alteration of the sine wave by the fan speed controller. Refer to Page 9 for maximum motor operating amps.

Filters

1. Filters, if supplied, should be replaced or removed after system start-up.
2. If filters are used beyond system start-up, they should be changed regularly to avoid excessive restriction of airflow. Frequency would depend on environment.
3. Contact your Price representatives for details on replacement filter media.

Air Balancing Procedure

Before Air Balancing the terminal unit, the following general items should be verified.

1. The primary fan system is operating at the specified volume, static pressure, rpm and current.
2. Return filters (if supplied) are clean.
3. All balancing dampers are adjusted and locked. Dampers downstream of the terminal unit should be proportionally balanced.
4. Thermostats are calibrated and operational.
5. All duct work and connections are free from leaks.
6. Sufficient duct static pressure is available at the terminal primary air inlet.
7. All diffusers are installed and adjusted for the proper air pattern.
8. For motors a minimum of 0.1" W.G. downstream static pressure is required to prevent overheating of the fan motor. For units with electric heaters a minimum of 0.2" W.G. is required.
9. The primary air volume (both minimum and maximum set points) is factory calibrated for pneumatic or electric controls supplied by Price. If field adjustment should be necessary, follow the appropriate calibration procedures for the controller type supplied with the unit. If DDC controls are supplied, refer to the control contractor's documentation for calibration instructions.
10. Set the thermostat to full cooling. The fan should be on and the primary air valve at maximum airflow. Verify the airflow with the sensor taps or pitot tube traverse. Adjust if necessary.
11. Set the thermostat to full heating. The fan should be on and the primary air valve at minimum flow. Verify the primary air volume with sensor taps or pitot tube traverse. Adjust if necessary.
12. The fan volume must be field adjusted with the fan speed controller. Fan curves on Page 9 indicate the volume range of each size unit. Adjust the speed control until the desired airflow is measured at the outlets. Note that, if the primary air valve has a minimum setting, the outlet volume will be the summation of fan and primary airflow.

ECM Motor Adjustment

1. Remove the electrical control cover and connect the leads from a DC Voltmeter to the terminals indicated.
2. Refer to the Test Point Chart for the relevant size unit being adjusted.
3. Determine the test point voltage from the chart or formula based on the desired airflow.
4. Adjust the manual speed control dial on the outside of the box with a screwdriver until the test point voltage is achieved.
5. Wait a few seconds for the ECM motor to adjust its speed and then verify fan flow measurements at the supply outlets.
6. If necessary, fine-tune the speed control in accordance with the measured outlet flow

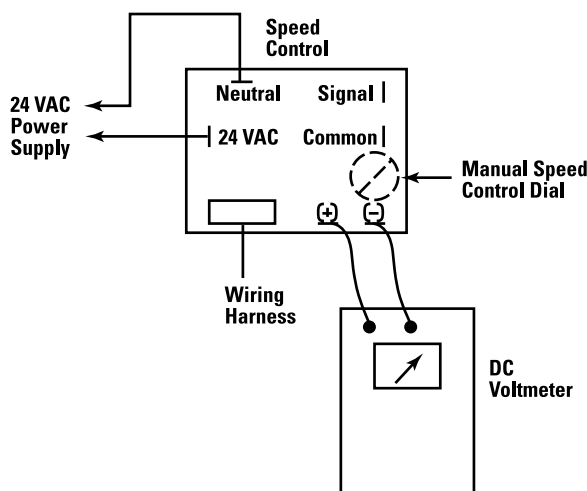

Operating Guidelines

1. Minimum downstream duct static pressure of 0.10 inches W.G. must be maintained to prevent overheating of the fan motor. Overheating of the fan motor can cause the unit to trip the thermal overload and reduce motor life.
2. If electric duct heaters are supplied, 70-cfm/kW minimum airflow across the heater must be maintained.
3. If electric duct heaters are supplied, the discharge air temperature must not exceed 120°F (49°C).

Fan Performance Curves - FPVLP, FEVLP, FDVLP - Standard Motor

Unit Size 20

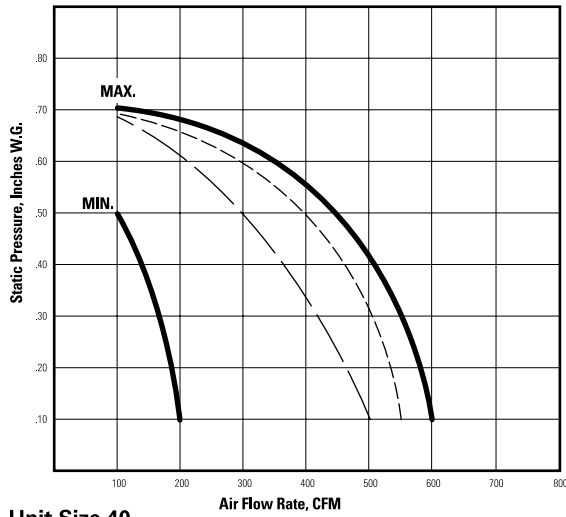

Unit Size 30

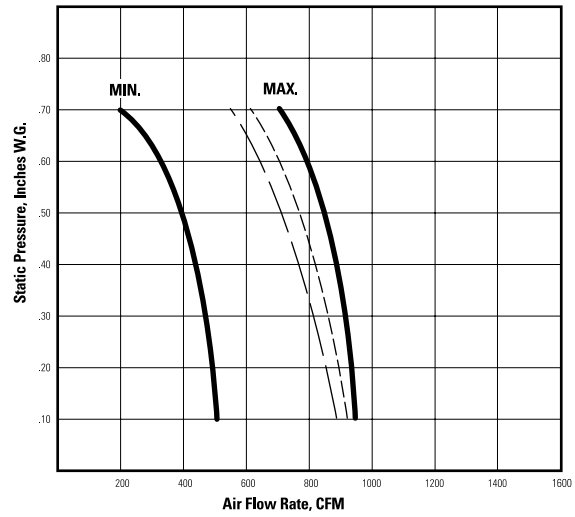

Unit Size 40

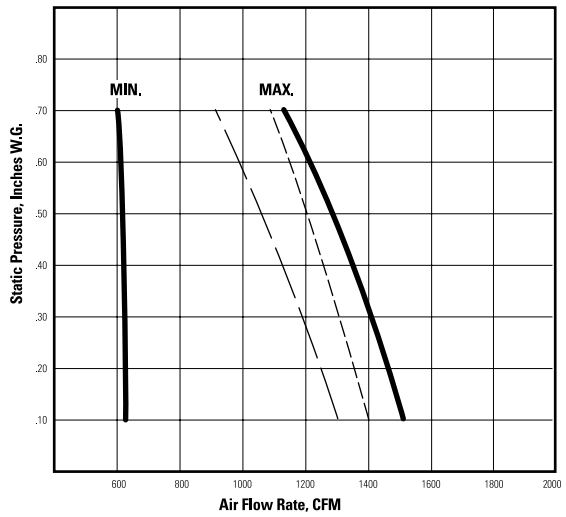

Maximum Flow

- No Coil or Electric Coil
- - - 1 Row Water Coil
- · - 2 Row Water Coil

Note: Data obtained in accordance with ARI Standard 880-98.

Caution to Contractors

Fan powered terminal units are not intended for use as temporary heat or ventilation during building construction. The terminal units are not designed nor equipped to operate in a dusty construction environment. Recirculating fan wheels can become coated with construction dust, resulting in an unbalanced wheel. This in turn can contribute to reduced motor life. Inlet air filters would provide little protection as they would quickly become plugged with construction dust.

A fan powered terminal unit should never be operated if the downstream ductwork has not been installed. A minimum of 0.1" W.G. downstream static pressure resistance is required for safe operation of the fan motor. For units with electric heaters a minimum of 0.2" W.G. is required.

Please Note:

Price cannot warrant against unauthorized operation under conditions as outlined on this page.

Standard Motor Data

Unit	Motor	Full Load Amps			
		115/1/60 V/Ø/Hz	208/1/60 V/Ø/Hz	240/1/60 V/Ø/Hz	277/1/60 V/Ø/Hz
20	1/8	2.4	1.1	1.1	1.1
30	1/4	5.2	1.8	1.7	1.6
40	1/2	8.0	3.1	3.1	3.1

ECM Motor Data

Unit	Motor	Full Load Amps		
		115/1/60 V/Ø/Hz	240/1/60 V/Ø/Hz	277/1/60 V/Ø/Hz
20	1/2	2.9	1.4	1.2
30	1/2	5.6	2.8	2.5
40	1/2	6.0	2.9	2.9

Note: FLA at 0.2" W.G. (50 Pa) External Static Pressure

Fan Performance Curves - FPVLP, FEVLP, FDVLP - ECM Motor

Unit Size 20 - No Coil, 1 and 2 Row Coil*

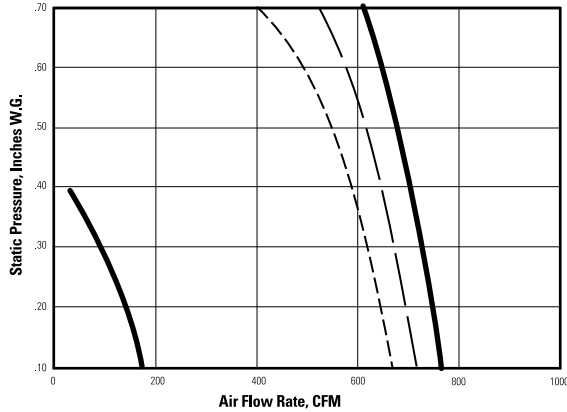

Unit Size 30 - No Coil

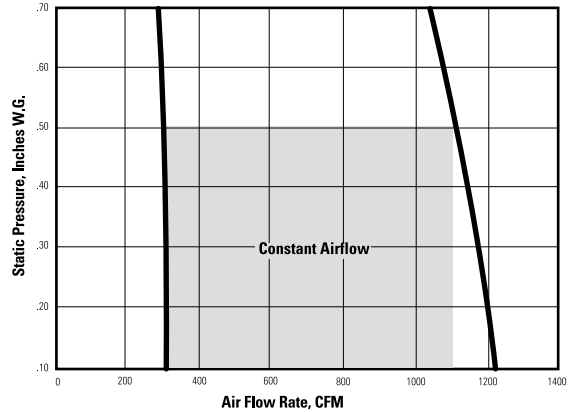

Unit Size 30 - 1 Row Coil

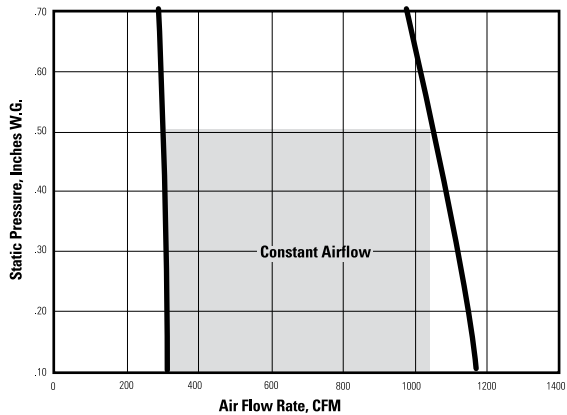

Unit Size 30 - 2 Row Coil

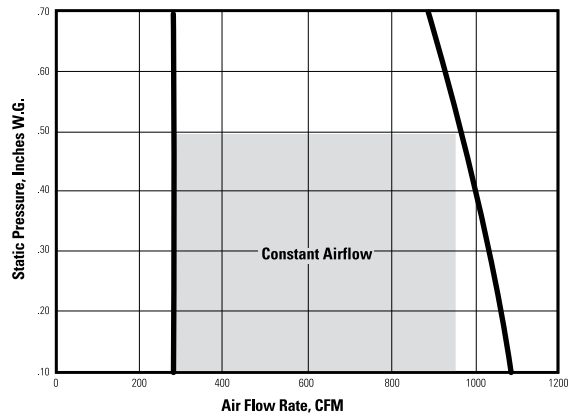

Unit Size 40 - No Coil

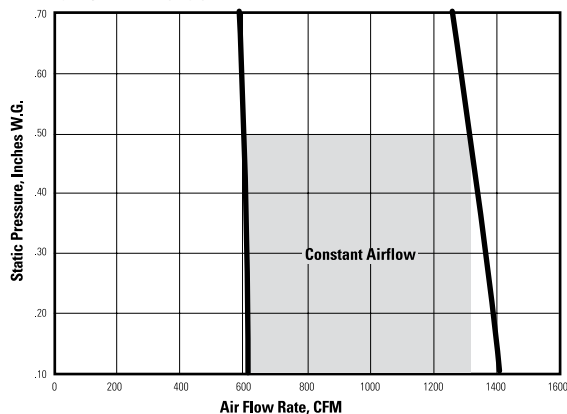

Unit Size 40 - 1 Row Coil

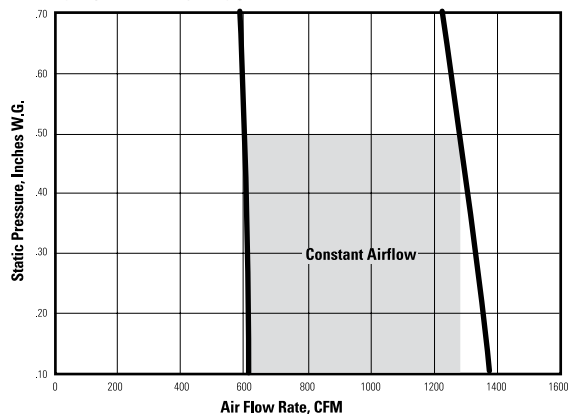

Unit Size 40 - 2 Row Coil

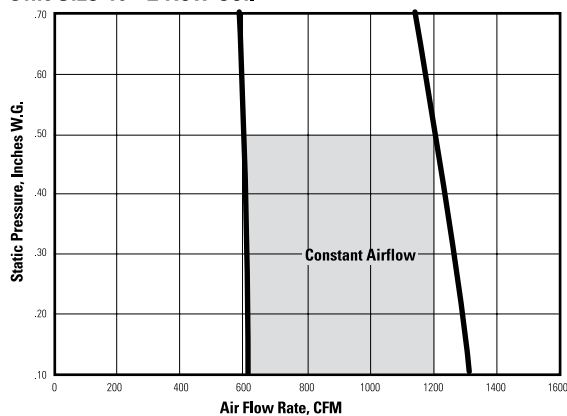

*** Note:** Unit size 20 can not be programmed for factory set fan flow. The fan air volume will vary as the external static pressure varies in accordance with the fan curves illustrated. All other features and benefits of the ECM motor apply to the size 20 unit.

Caution to Contractors

Fan powered terminal units are not intended for use as temporary heat or ventilation during building construction. The terminal units are not designed nor equipped to operate in a dusty construction environment. Recirculating fan wheels can become coated with construction dust, resulting in an unbalanced wheel. This in turn can contribute to reduced motor life. Inlet air filters would provide little protection as they would quickly become plugged with construction dust.

A fan powered terminal unit should never be operated if the downstream ductwork has not been installed. A minimum of 0.1" W.G. downstream static pressure resistance is required for safe operation of the fan motor. For units with electric heaters a minimum of 0.2" W.G. is required.

Please Note: Price cannot warrant against unauthorized operation under conditions as outlined on this page.

Electronic Airflow Adjustment Procedure

In order to correct for poor inlet conditions (which cause inaccurate airflow sensing) or changing design parameters, it may be necessary to adjust the factory set minimum and maximum airflow rates of a fan powered low profile terminal unit in the field. These adjustments are performed at the wall-mounted thermostat. In the event that inlet conditions to the terminal are causing the inaccuracies, the calibration curves referred to in the procedures will no longer be valid. In this case, either a duct traverse or air outlet measurement will be required to establish true air volumes.

Calibration Procedure for Velocity Adjustments made at Thermostat

A. Required Tools:

1. Small flat blade (1/8") screwdriver.
2. Digital Voltmeter capable of displaying a 0 to 10 VDC range which will display in .01 VDC increments.
3. Test Leads (#HSO-5001).

B. Remove Thermostat Cover

Thermostat Cover is removed by releasing the mounting screws on either side of the cover.

CTE-5101 Cooling Thermostat

1. Be certain the ambient room temperature at the thermostat is within the range of the thermostat (55°F to 85°F / 13°C to 29°C).
2. Connect Digital Voltmeter to the meter taps (1) (fig. 1) on the face of the room thermostat using test leads (see fig. 2).
3. Adjust the cooling setpoint slider (2) all the way to the right for minimum cooling.
4. Read the DC voltage across the meter taps on the cooling (right) side. Adjust the minimum setpoint (MIN INCR) Potentiometer (3) (clockwise to increase or counter-clockwise to decrease) to the desired DC voltage. The DC voltage may be determined from the calibration curves or by direct air flow measurement.

Note: The minimum setpoint must be adjusted first. Adjustment of the MIN INCR Potentiometer directly affects the maximum setpoint.

5. Adjust the cooling setpoint slider all the way to the left for maximum cooling.
6. Read the DC voltage across the meter taps on the cooling (right) side. Adjust the maximum setpoint (MAX INCR) Potentiometer (4) (clockwise to increase or counter-clockwise to decrease) to the DC voltage equal to the desired flow (CFM). The DC voltage may be determined from the calibration curves or by direct air flow measurement.

Note: The maximum setpoint must be adjusted last. Adjustment of the MIN INCR Potentiometer directly affects the maximum setpoint.

7. Return the cooling setpoint slider to the desired setpoint. Insert setpoint slider stops if required. Replace the thermostat cover.

Fig. 1 CTE - 5101

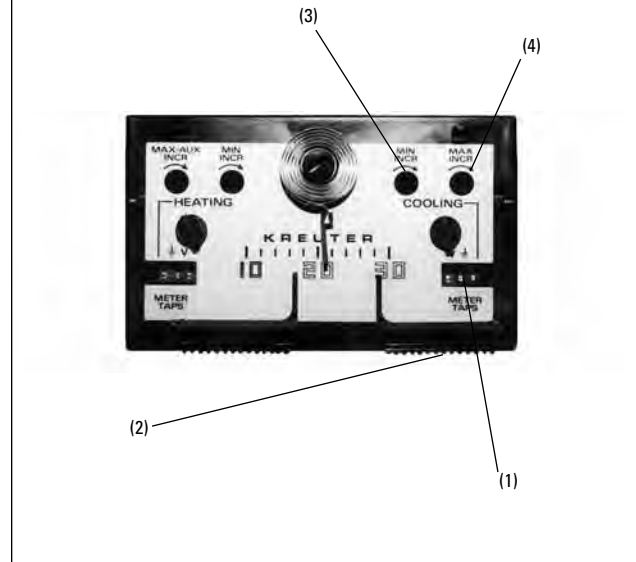

Fig. 2 Test leads and meter hook-up



Airflow Adjustment Procedure

CTE-5105 Day/Night Thermostat

Cooling side of the thermostat.

1. Adjust MIN/MAX settings using same procedure as CTE-5101

Note: The maximum set point must be adjusted last. Adjustment of the MIN INCR Potentiometer directly affects the maximum set point.

Heating side of the thermostat.

1. Be certain the ambient room temperature is within the range of the thermostat (55° F to 85° F) (13° C to 29° C).
2. Connect Digital Voltmeter to the metre taps (8) (fig 4) on the face of the room thermostat using Kreuter test leads (PT#HSO-5001) (see fig. 2).
3. Adjust the night Set Point Slider (7) all the way to the right for minimum night.
4. Read the DC voltage across the metre taps on the heating (left) side. Adjust the minimum set point (MIN INCR) Potentiometer (5) (clockwise to increase or counter-clockwise to decrease) to the desired DC voltage. The DC voltage may be determined from the calibration curves or by direct air flow measurement.

Note: The minimum set point must be adjusted first. Adjustment of the MIN INCR Potentiometer directly affects the maximum set point.

5. Adjust the night Set Point Slider all the way to the left for maximum night.
6. Read the DC voltage across the metre taps on the heating (left) side. Adjust the maximum set point (MAX/AUX INCR) Potentiometer (6) (clockwise to increase or counter-clockwise to decrease) to the DC voltage equal to the desired flow (CFM). The DC voltage may be determined from the calibration curves or by direct air flow measurement.

Note: The maximum set point must be adjusted last. Adjustment of the MIN INCR Potentiometer directly affects the maximum set point.

Fig. 3 CTE-5105

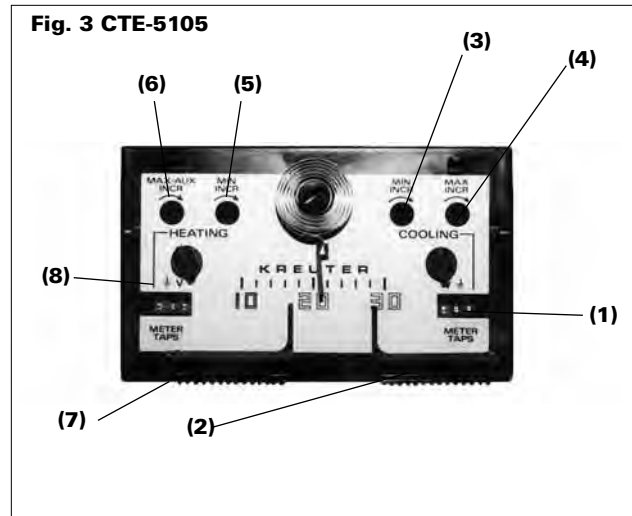

Electronic Calibration Curves and Equations

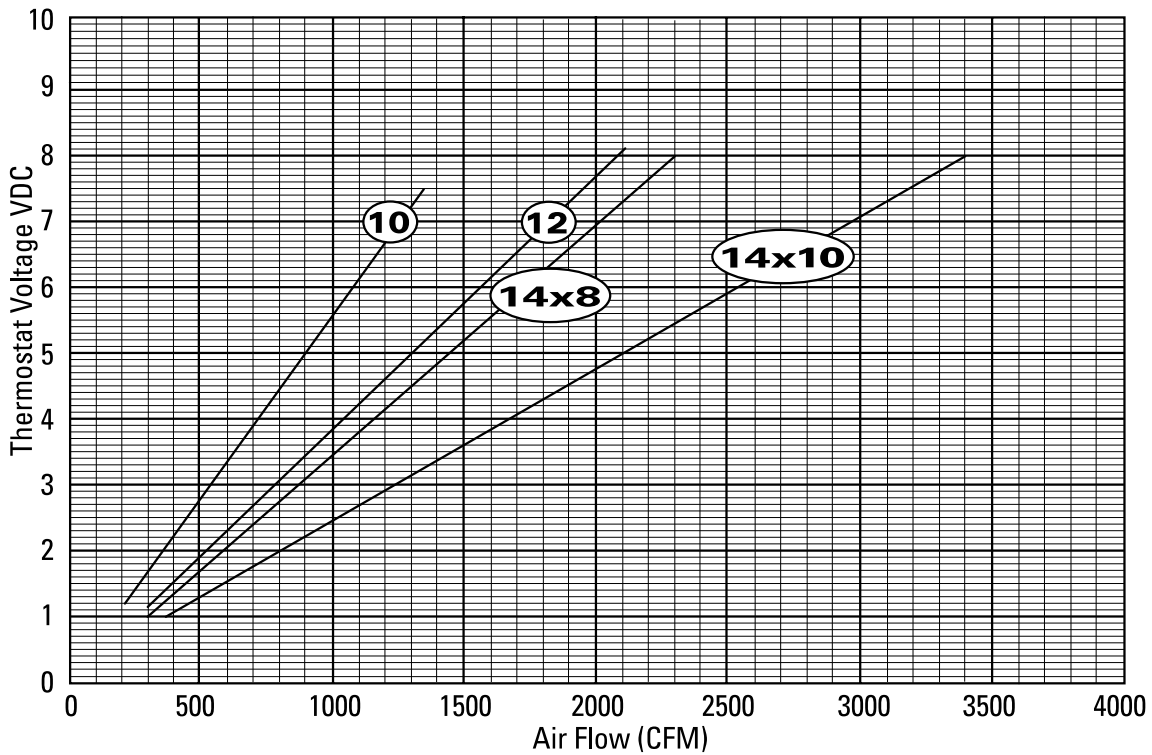
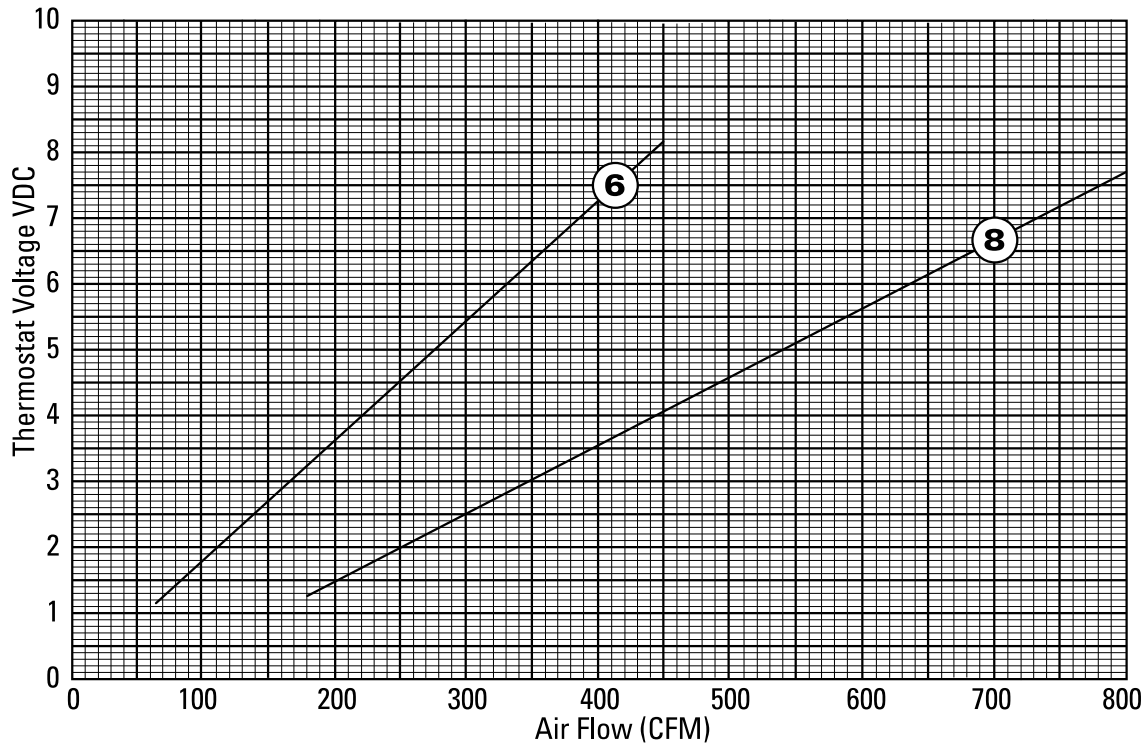

Calibration Equations

Size	Equation
6	$VDC = CFM / 54$
8	$VDC = CFM / 103$
10	$VDC = CFM / 181$
12	$VDC = CFM / 259$
14 x 8	$VDC = CFM / 286$
14 x 10	$VDC = CFM / 360$

Pneumatic Calibration Procedures

CP100/CP200

General

1. Remove the protective metal cover.
2. Aligned markings on the face and dials of the controller indicate that the factory settings are intact.
3. Remove the caps from the tees in the HI (red) and LO (green) tubes leading from the airflow sensor in the assembly inlet. Connect a differential pressure gauge to the tees. A gauge with a 0 to 1 inch w.g. scale is recommended.
4. Refer to the calibration curve for the size assembly being serviced. From the curve on Page 16, read the differential pressure across the sensor for the required airflow.
5. Alternately, calculate the differential pressure from the equations on Page 16.

CP100 (If supplied)

1. Adjust the minimum (LO) airflow limit first.
2. Set the thermostat signal to 0 psi, or disconnect the thermostat tube to the controller.
3. Turn the minimum (LO) dial on the controller (center knob) until the gauge reads the required differential pressure. Turn the dial slowly, allowing time for the damper actuator to complete its travel in response to the adjustments (verify the minimum set point by cycling the thermostat pressures).
4. Apply 15-psi minimum air pressure to the thermostat connection at the controller.
5. Turn the maximum (HI) dial on the controller (outer knob) until the gauge reads the required differential pressure. Turn the dial slowly, allowing time for the damper actuator to complete its travel in response to the adjustments (verify the maximum set point by cycling the thermostat pressure).

CP200 (If supplied)

1. Adjust the maximum (HI) airflow limit first.
2. Set the thermostat signal to 0 psi, or disconnect the thermostat tube to the controller.
3. Turn the maximum (HI) dial on the controller (center knob) until the gauge reads the required differential pressure. Turn the dial slowly, allowing time for the damper actuator to complete its travel in response to the adjustments (verify the minimum set point by cycling the thermostat pressures).
4. Adjust the minimum (LO) airflow limit.
5. Apply 15 psi minimum air pressure to the thermostat connection at the controller.
6. Turn the minimum (LO) dial on the controller (outer knob) until the gauge reads the required differential pressure. Turn the dial slowly, allowing time for the damper actuator to complete its travel in response to the adjustments (verify the maximum set point by cycling the thermostat pressure).

CP101

General

1. Reconnect the thermostat tube to the controller if it has been removed during the calibration procedure.
2. Disconnect the gauge and replace the caps on the tees.
3. Replace the protective cover.

CP101

A. Damper Action

1. Damper action is factory set. To reset action, loosen damper selection switch screw and align desired action with the damper position. Retighten screw.
2. Actuator must be repositioned to provide appropriate fail-safe position.

B. Reset Start Point

1. Reset start point is factory calibrated to the specified setting on the control assembly label.
2. To field adjust, remove the gauge tap cap at "G" and attach a 0-30 psi pressure gauge.
3. Adjust the thermostat pressure at "T" port to the desired start point value with a gradual switch or pressure regulator (start point is lowest span pressure).
4. Adjust reset start knob until the gauge pressure begins to increase slightly (greater than zero but less than 0.3).
5. Replace gauge tap cap.

C. Reset Span

1. Reset span is factory calibrated to the specified setting on the control assembly label.
2. To field adjust, remove the gauge tap cap at "G" and attach a 0-30 psi pressure gauge.
3. Adjust the thermostat pressure at "T" port to above 15 psi.
4. Adjust reset span knob until the gauge pressure is equal to the desired reset span (total span pressure, not end span pressure).
5. Replace gauge tap cap.

D. Air Volume Limits

1. Remove the caps from the tees in the HI (red) and LO (green) tubes leading from the air flow sensor in the assembly inlet. Connect a differential pressure gauge to the tees. A gauge with a 0 to 1 inch w.g. scale is recommended.
2. Refer to the calibration curve for the size assembly being serviced. From the curve, read the differential pressure across the sensor for the required airflow.
3. Alternately, calculate the differential pressure from the equations on Page 16.

Pneumatic Calibration Procedures (continued)

Direct Acting Cooling or Reverse Acting Heating

1. Adjust the minimum airflow limit first.
2. Set the thermostat signal to 0 psi or disconnect the thermostat tube from the controller.
3. Adjust the "LO STAT" dial on the controller (center knob) until the gauge reads the required differential pressure for minimum air volume. Turn the dial slowly, allowing time for the damper actuator to complete its travel in response to the adjustments.
4. Adjust the maximum airflow limit, after verifying the minimum airflow limit is set correctly.
5. Apply 15-psi minimum air pressure to the thermostat connection at the controller.
6. Adjust the "HI STAT" dial on the controller (outer knob) until the gauge reads the required differential pressure for maximum air volume. Turn the dial slowly, allowing time for the damper actuator to complete its travel in response to the adjustments.
7. Cycle the thermostat several times. This can be quickly accomplished by removing the cap from the gauge tap (Port G) and varying the bleed rate with finger pressure. Replace the cap and check the airflow limits. If set points have changed, repeat steps 1 to 7.

Reverse Acting Cooling or Direct Acting Heating

1. Adjust the maximum airflow limit first.
2. Set the thermostat signal to 0 psi or disconnect the thermostat tube from the controller.
3. Adjust the "LO STAT" dial on the controller (center knob) until the gauge reads the required differential pressure for maximum air volume. Turn the dial slowly, allowing time for the damper actuator to complete its travel in response to the adjustments.
4. Adjust the minimum airflow limit, after verifying the maximum airflow limit is set correctly.
5. Apply 15-psi minimum air pressure to the thermostat connection at the controller.
6. Adjust the "HI STAT" dial on the controller (outer knob) until the gauge reads the required differential pressure for minimum air volume. Turn the dial slowly, allowing time for the damper actuator to complete its travel in response to the adjustments.
7. Cycle the thermostat several times. This can be quickly accomplished by removing the cap from the gauge tap (Port G) and varying the bleed rate with finger pressure. Replace the cap and check the airflow limits. If set points have changed, repeat steps 1 to 7.

General

1. Always adjust the "LO STAT" dial first.
2. After calibration is complete, reconnect the thermostat tube to the controller if it has been removed during the calibration procedure.
3. Disconnect the gauge and replace the caps on the tees.
4. Replace the protective metal cover.

DDC Calibration Procedures

Refer to control contractor documentation for details.

Airflow Sensor

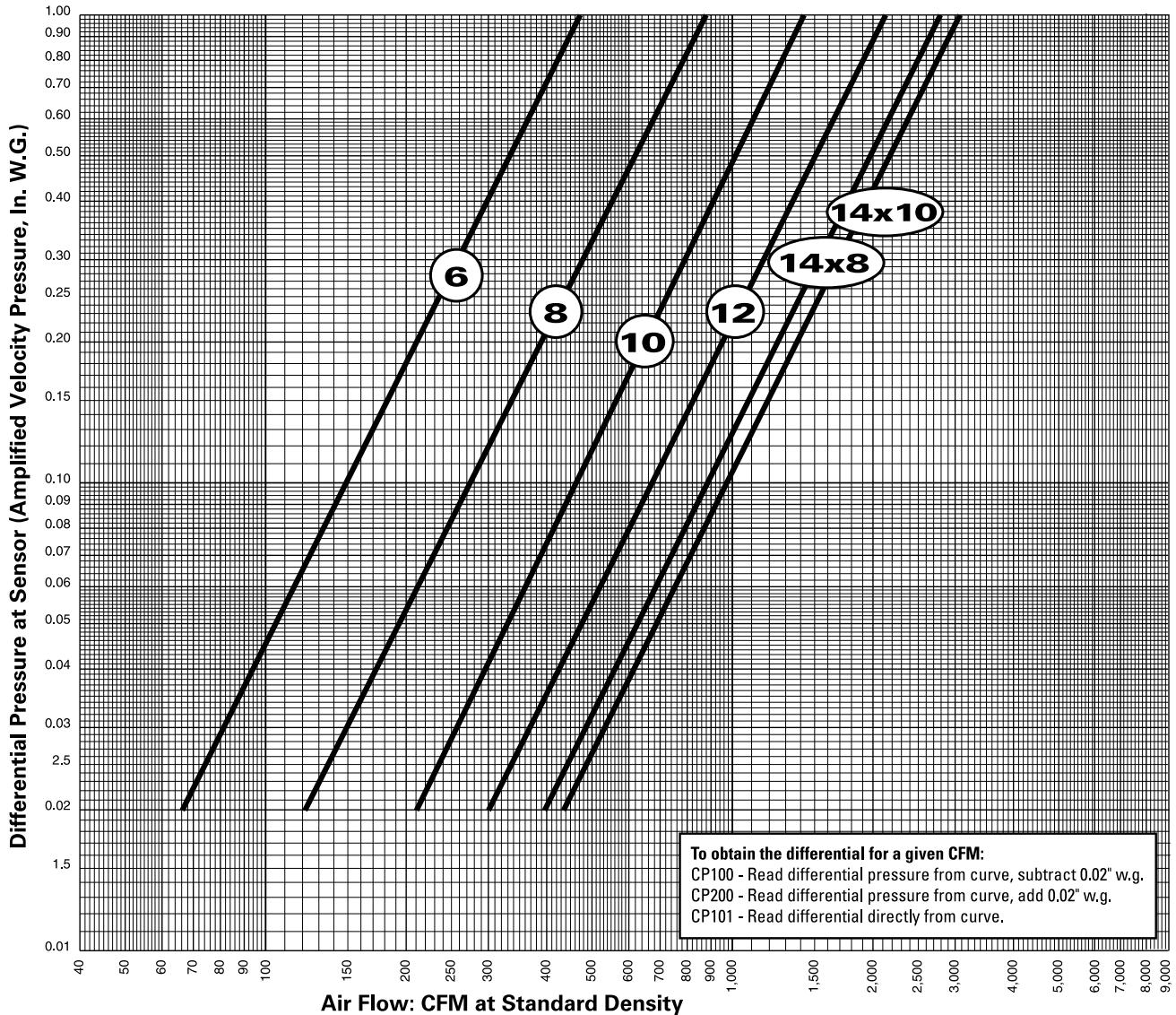

Calibration Equation

$$VP = \left(\frac{Q}{K} \right)^2$$

- VP** - differential pressure at sensor, inches w.g.
Q - air flow rate, cfm at standard density.
K - calibration constant

Unit Size	K
6	468
8	890
10	1487
12	2141
14x8	2084
14x10	2760

Notes

- Gauge taps are normally supplied with the pneumatic controls to allow field measurement of the differential pressure at the sensor with a manometer, magnahelic or other measuring device.
 If the terminal velocity controls utilize a flow-through transducer, a proper velocity pressure reading will NOT be read at the gauge taps and the calibration curves CANNOT be used for field measurement. The flow-through transducer operates on the principle of mass flow rather than pressure differential.
 Controls utilizing a dead-ended pressure transducer will allow field measurement with the gauge taps and calibration curves provided.
- Setting flow limits for a differential pressure of less than 0.02 inches w.g. is NOT recommended. Stability and accuracy of flow limits may not be acceptable due to low velocity pressure signal. Performance will vary depending on the terminal unit controls provided.
- For field calibration of airflow limits refer to the control contractor's documentation.

Troubleshooting Guide

<p>General</p>	<ol style="list-style-type: none"> 1. Confirm fan box size and rating with blueprint and box schedule (check Control Assembly label on terminal unit). 2. Visually check pneumatic and electrical connections with the Control Wiring diagram(s) located inside the electrical enclosure or in the applicable controls brochure. 3. Verify that the supply voltage is the same as specified on the control diagram(s) or Voltage Information label. 4. Confirm main air pressure (15 psi min., 25 psi max.)
<p>Noise</p>	<ol style="list-style-type: none"> 1. Foreign material in fan. 2. Relay chatter. 3. Fan or duct size selection too small for application causing high air velocity. 4. Vibrating ductwork. 5. Unbalanced fan wheel causing it to hit the housing.
<p>Primary Air Volume not as Specified</p>	<ol style="list-style-type: none"> 1. Check controller operation – adjust if necessary. 2. Check for proper control signal from thermostat. Cycle thermostat and monitor. 3. Confirm sufficient inlet duct static pressure is available at the terminal unit. 4. There should be a minimum of 3 duct diameters of straight inlet duct, either sheet metal or flexible. It is to be the same size as the inlet, between the unit inlet and any transition, take-offs or fittings. Poor inlet conditions may necessitate controller re-calibration. 5. Check the flow sensor for blockage.
<p>Air Volume Not As Specified</p>	<ol style="list-style-type: none"> 1. Check filter for excessive dust build-up. 2. Check fan for particle blockage. 3. Check coils for particle blockage. 4. Measure downstream static pressure, it must be no less than 0.10 inches W.G. in order to keep the fan from overheating (0.2" for units with electric heat). 5. Verify that the supply voltage is the same as specified on the wiring diagram. See wiring diagram pasted on the inside of the electrical enclosure or in the applicable controls brochure. 6. Insulating duct liner loose. 7. Unit was not air balanced. See Air Balancing Procedure on Page 8. 8. Leaks in ductwork. 9. Obstruction in ductwork. 10. Sharp elbows near fan outlet. 11. Improperly designed turning vanes.
<p>Fan Does Not Operate</p>	<ol style="list-style-type: none"> 1. Check the unit against the provided Control and Wiring diagrams. See inside cover of the electrical enclosure for diagrams. 2. Verify that the disconnect switch or breaker is not opened. 3. Check for proper control signal from thermostat. See thermostat for full heating and monitor output. 4. If fan cycles on and off, check the downstream static pressure. It must be no less than 0.10 inches W.G. in order to keep the fan from overheating (0.2" for units with electric heat). 5. Fan wheel may be touching the housing.

Replacement Parts

Component	Part#	Description
Fan Motors (Totally Open)	019 588-001	208/240V – 1/8HP (Size 20)
	019 589-002	208/240V – 1/4HP (Size 30, 50)
	019 589-003	208/240V – 1/2HP (Size 40)
	019 150-001	115V – 1/8HP (Size 20)
	019 152-002	115V – 1/4 HP (Size 30, 50)
	019 154-003	115V – 1/2 HP (Size 40)
	019 151-001	277V – 1/8 HP (Size 20)
	019 153-002	277V – 1/4 HP (Size 30)
	019 155-003	277V – 1/2 HP (Size 40)
Fan Speed Controllers	233 563-100	8A / 115V (Size 20-40)
	233 563-200	8A / 277/240/208V (Size 20-40)
Capacitors	019 874-001	5 mfd (Size 20, 30)
	019 874-006	7.5 mfd (Size 30)
	019 874-002	10 mfd (Size 30, 40)
	019 874-007	20 mfd (Size 40)
Blowers	100 185-001	Size 20
	100 185-002	Size 30
	100 185-003	Size 40
Controllers	019 815-001	Electronic CSP-5001 Controller/Actuator
	076 730-002	Pneumatic CP100 Controller
	076 824-001	Pneumatic CP200 Controller
	076 823-001	Pneumatic CP101 Controller
Actuators	019 915-001	Electric MEP-5001 24V Floating
	019 096-001	Electric ML6161B 24V Floating
	076 857-001	Pneumatic MCP-8031 Actuator
Thermostats	076 863-001	Electronic Cooling (CTE-5101)
	019 723-001	Electronic Heating-Cooling (CTE-5103)
	019 726-000	Electronic Cooling w/Reheat (CTE-5104)
Control Components	076 813-001	Pressure Diverting Relay
	076 811-001	Lo Pressure Selector
	076 817-001	Hi Pressure Selector
	019 873-001	P-E Switch
	019 436-004	115/24V – 20A Transformer
	019 436-001	115/24V – 50A Transformer
	019 436-005	277/24V – 50A Transformer



PRICE
INDUSTRIES

2975 Shawnee Ridge Court
Suwanee, Georgia USA 30024
Ph: 770.623.8050 Fax: 770.623.6404



PRICE
INDUSTRIES

1290 Barrow Industrial Parkway
Auburn, Georgia USA 30011



PRICE
INDUSTRIES

999 North Thornton Road
Casa Grande, Arizona USA 85222-3809



e.h. price
LIMITED

638 Raleigh Street
Winnipeg, Manitoba Canada R2K 3Z9
Ph: 204.669.4220 Fax: 204.663.2715

The founding principles of our company have never changed - business integrity, first class service and a commitment to people. Price manufacturing endeavors arose from our belief that we could supply superior products and services at a reasonable price. Our mission is to become the world-wide supplier of preference for air distribution products and services. You can rely on Price – our products and services – with confidence.

Warranty: The Company warrants and guarantees that all goods within this catalog that have been manufactured by the Company have been manufactured in accordance with the specifications published herein and will be free from defects in material and workmanship for a period of twelve (12) months from the date of Bill of Lading issued by the Company. The Company will replace defective product at its option, but will not be responsible for labor or material charges in replacing product or consequential damages. Any installation not conforming with the Company's specifications, manuals, bulletins or instructions or any misuse or any modification not authorized by the Company voids this warranty. This warranty is in lieu of all Provincial, State, and Federal statutory warranties and the conditions herein are in substitution and replacement of such warranties, statutory or otherwise.

Your Local Price Representative:

Grilles & Diffusers

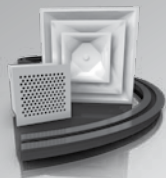

Critical Environments

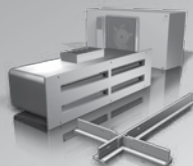

Terminals

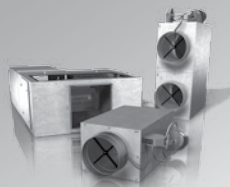

Sustainable Building



Noise Control

