



PRICE[®]

DUAL DUCT TERMINAL UNITS

INSTALLATION MANUAL



Date: 04/11
Reference #: F-61

www.price-hvac.com

General

Price Dual Duct Terminals are available with pneumatic, electronic or direct digital controls (DDC) for variable or constant volume operation. In most cases, pneumatic and electronic controls are factory supplied and mounted. In the case of DDC controls, they are often supplied by the controls contractor and either factory or field mounted. For information concerning controls, components, sequence of operations, etc. for DDC controls supplied by the controls contractor, please refer to the documentation provided by the controls contractor.

Damper rotation is always counter clockwise to the closed position. An identification mark on the end of the shaft indicates the damper position.

Capped tees are provided in the sensing lines from the amplifying sensor for pneumatic controls. These allow for field connections to a differential pressure gauge for accurate air flow measurement. (Not applicable with electronic controls.) The factory supplied sensing lines are color coded. Red indicates the total pressure or "HI" line, which should be connected to the upstream nipple on the sensor. Green indicates the static pressure or "LO" line, which should be connected to the downstream nipple on the sensor.

For electronic and digital controls, a controls enclosure may be provided to house the terminal control components. The enclosure's cover is removable with two sheet metal screws. A protective shroud may be provided for pneumatic units to protect the controls from damage in shipping.

The velocity sensors are normally supplied with the terminal unit. However, in some cases a flow sensing device supplied by a controls contractor may be factory or field mounted. Refer to the submittal drawing for illustration.

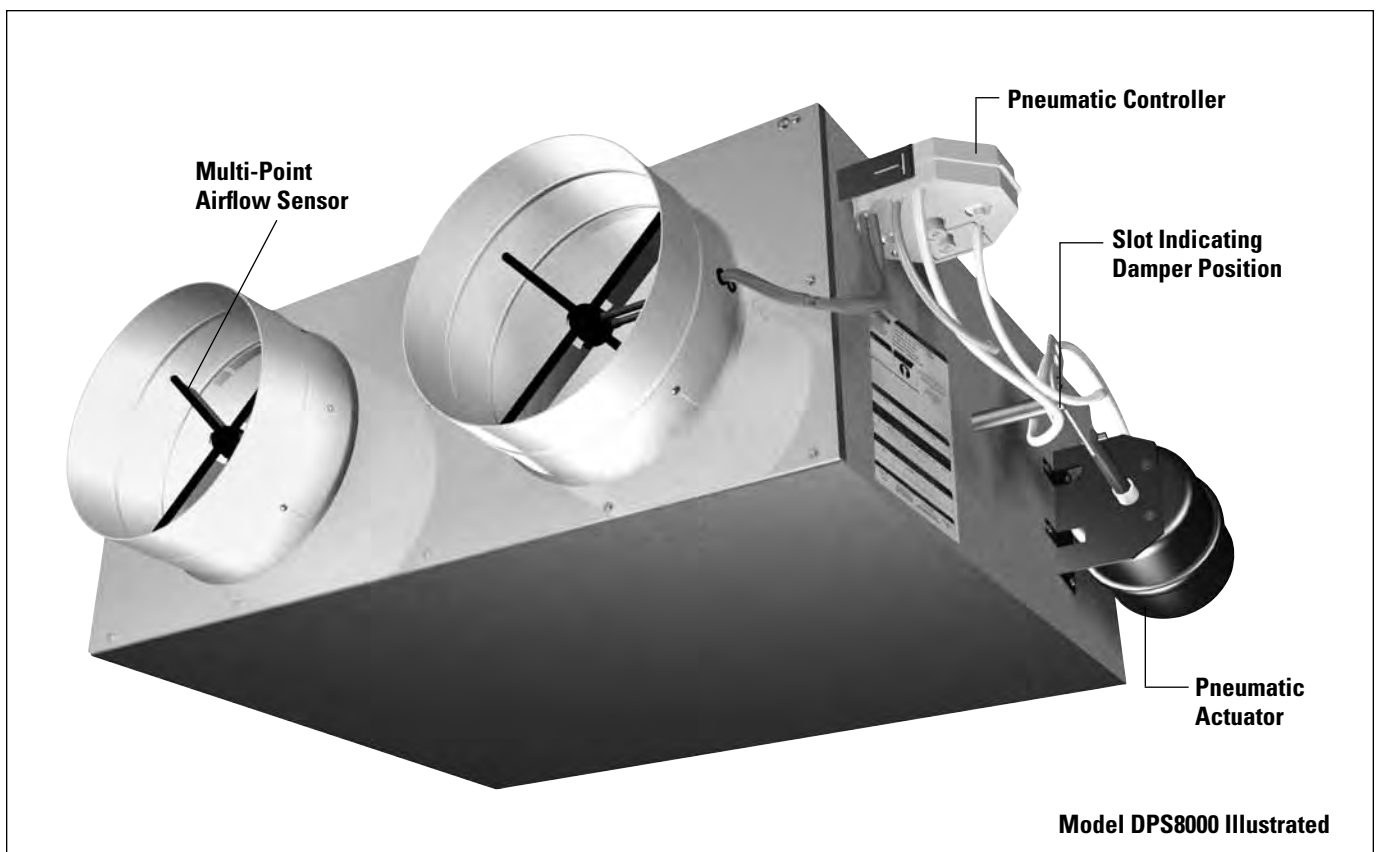

Receiving Inspection

All Price Dual Duct Terminals are inspected prior to shipping. After unpacking the assembly, check it for damage. If any damage to the products is found, report it immediately to the delivery carrier. During unpacking and installation, do not handle the unit by the inlet or discharge velocity sensors.

WARNING: DO NOT TAMPER WITH THE CONTROL COMPONENTS

Product Key

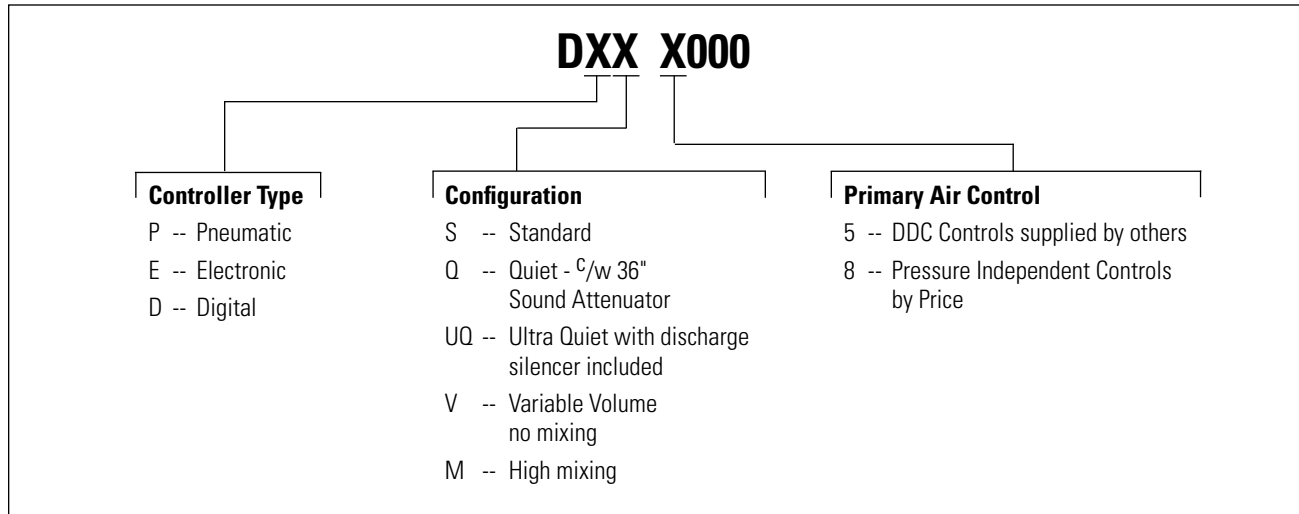

Flow Sensor Orientation

DxS, DxQ, DxUQ and DxM Series are supplied with SP300 flow sensors on both inlet ducts and one downstream total flow sensor at the discharge.

For pneumatic and electronic sequences the cold deck inlet sensor and downstream total flow sensors are utilized for all standard constant and variable volume configurations. The hot deck inlet sensor is not used.

Where DDC controls are supplied by the controls contractor for factory or field mounting, the appropriate sensors required will depend on the model of controls and application. To accommodate all variations and allow future field modification, both inlet and downstream sensors are supplied as standard.

DxV series is not meant for constant volume applications so air flow sensors are only supplied at both inlets and none on the discharge end.

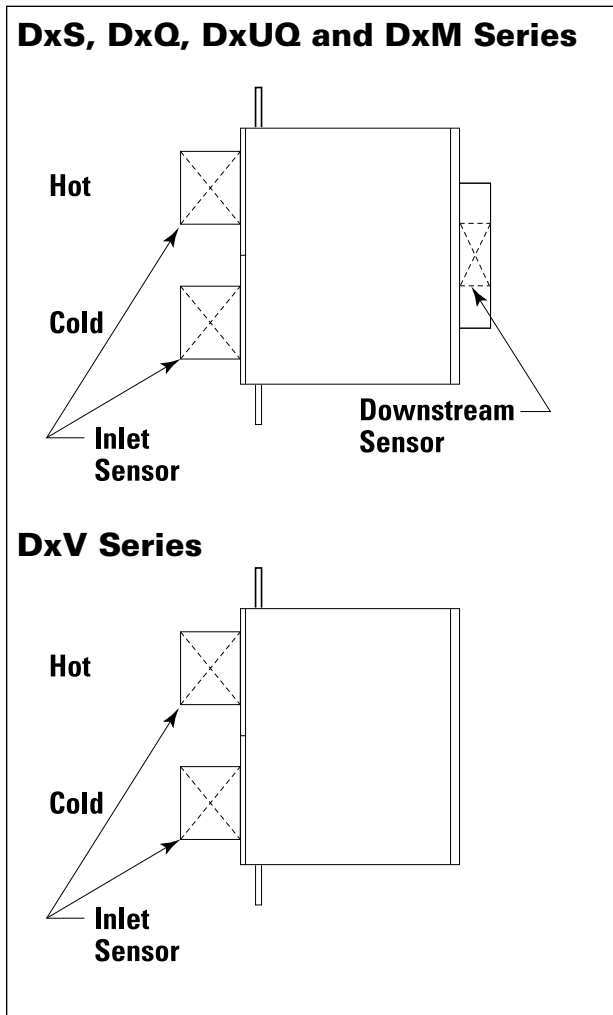

Installation

Mounting the Unit

1. Use the support method for rectangular duct described in the job specifications.
2. Price Dual Duct terminal units are designed to be mounted in the direction indicated by the Control Assembly Label found on either side of the terminal.
3. Do not install tight to slab and avoid contact with other obstacles such as rigid conduit and sprinkler piping. This can cause vibration and noise transmission.
4. Install the unit in a location that allows free access to the unit as well as all control components.
5. Ensure main power to the terminal has been disconnected prior to performing any electrical work or inspecting of the circuitry. (Not applicable for pneumatic units.)

WARNING: Do not tamper with control components.

Duct Connection

1. For accurate airflow control, there should be a minimum of 3 duct diameters of straight inlet duct, either sheet metal or flexible, same size as the inlet, between the unit inlet and any transition, take-offs or fittings. Use of transitions or elbows at the inlet is to be avoided. Where flexible duct is used it should be pulled tight to eliminate sags or folds.
2. To control radiated noise in critical applications it is recommended that the inlet ducts be fabricated of a minimum gauge of 24 in place of flexible duct.
3. To prevent excessive air leakage, all cleat joints should be sealed with an approved duct sealer. This applies to all accessory connections as well as the basic terminal unit.
4. Holes that are drilled in the duct for testing or balancing purposes are to be sealed.

Air Volume Ranges

Size	HD & CD L/s Min.	HD & CD L/s Max.	HD & CD CFM Min.	HD & CD CFM Max.
4	21-106	35-106	45-225	75-225
5	30-165	54-165	63-350	115-350
6	31-189	64-189	66-400	135-400
7	47-260	87-260	99-550	185-550
8	62-354	116-354	132-750	245-750
9	79-472	151-472	167-1000	320-1000
10	104-613	201-613	221-1300	425-1300
12	147-897	285-897	313-1900	605-1900
14	204-1369	439-1369	431-2900	930-2900
16	268-1652	562-1652	568-3500	1190-3500

Electrical Connection

CAUTION: DISCONNECT ALL INCOMING POWER BEFORE ANY ELECTRICAL INSTALLATION OR SERVICE IS PERFORMED ON THE UNIT(S).

1. All field wiring is to be in accordance with the National Electrical Code ANSI/NFPA No. 70-1990 or the Canadian Electrical Code, Part 1, CSA Standard C 22.1-1990.
2. Check voltage requirements prior to power supply connection. Refer to the electrical label located near the electrical control box.
3. Refer to the control diagram supplied with each unit for field wiring of thermostat and any accessories.
4. If an Electric Reheat Coil has been supplied, refer to the electrical schematic which is permanently fixed to the underside of the electrical control cabinet door, prior to hook-up. Check the voltage requirements to ensure proper voltage supply is used.

Control Connections

PNEUMATIC

1. External control air connections are provided for main air and thermostat connections. These are to be piped according to the label on the inlet panel.
2. Main air supply must be clean and dry, delivered at 15 to 20 psi.
3. Ensure that the lines are not crimped or cut when installed.

ELECTRONIC

A wiring diagram is provided with each terminal. Thermostat and other accessories should be wired as indicated by the wiring diagram.

DIGITAL

If controls have been factory mounted, a wiring diagram will be included with the unit indicating factory mounted components. For field wiring of room sensors and other accessories, refer to documentation provided by the controls contractor.

Control Assembly Label



638 Raleigh Street
Winnipeg, MB R2K 3Z9
Phone: (204) 669-4220
Fax: (204) 668-5994

VAN SPECIFICATIONS / SPÉCIFICATIONS VAV

Price Order No / No Comm de Price:	46715
Branch PO / BC de la Succ:	555555
Customer PO BC du Client:	
Job Name / Nom du Projet:	O&M Manual
Package Tag / Étiquette du Colis:	O&M Manual
Unit Location / Localisation de l'Unité:	VAV-95

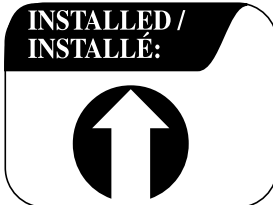

AIR DISTRIBUTION PRODUCTS /
PRODUITS DE DISTRIBUTION D'AIR

Manufactured By / Fabriqué Par
Price

638 Raleigh Street
Winnipeg, MB R2K 3Z9
Canada

Special Instructions / Instructions Spéciales: _____

Item	Model / Modèle	Size / Grandeur	Controller / Régulateur	Motor / Moteur		
1	DPS 8000	6	#2 CP101 Pneum. Control	Motor By Price		
Air Volume (cfm / l/s) / Volume d'Air (pcm / l/s)		Reset Span / Plage d'Opération	Damper / Volet	Thermostat	Coil Serpentin	Application
Min.	Max.					
150 71	350 CFM 165 L/s	8-13 PSI	N.O. - Cold	Direct Acting		Cooling

031600

Price Order No. / No. de Comm. de Price	Item	Model / Modèle	Size / Grandeur	Unit Location / Localisation de l'Unité
46715	1	DPS8000	6	VAV-95

Price Order No. / No. de Comm. de Price	Item	Model / Modèle	Size / Grandeur	Unit Location / Localisation de L'Unité
46715	1	DPS8000	6	VAV-95
Damper / Volet N.O. - Cold		Air Volume (cfm / l/s) / Volume d'air (pcm / l/s) Min.150 Max.350 CFM Min. 71 Max. 165 L/s		Settings / Réglages Min.0.10 Max.0.56 IN Min. 25 Max. 138 Pa
				Reset Span / Plage d'Opération 8-13 PSI

All Price Dual Duct terminal units are tagged with two control assembly labels as shown on the left (one on each side). The labels identify the model number, controller type, actuator type, thermostat action, damper action, location tag#, application and controller set points. Options, accessories and appropriate control diagrams are also identified. If field adjustment of the controller should become necessary, follow the appropriate procedure outlined in this manual. Note that all pneumatic controls must be calibrated in the position they are mounted.

All factory supplied controllers are tagged with a controller label as shown below.

For pneumatic units, the controller label indicates minimum and maximum air flow set points as well as the equivalent velocity pressures.

For electronic units, the controller label indicates air flow set points and equivalent DC output voltage from the thermostat.

For digital units, the controller label indicates air flow set points.

Digital Controls Section

For information regarding control components, wiring, sequence of operations, calibration, trouble-shooting, etc. please refer to the documentation provided by the controls contractor. For airflow sensor calibration curves and equations, refer to Pages 10 -12.

Pneumatic Controls Section

CP101 Reset Velocity Controller

Consult the appropriate Price Control Diagram for specific applications.

SPECIFICATIONS

Differential Pressure Range

0 to 1.0" w.g. (0 to 25.4mm w.g.)

Minimum Set Point Range

0 to 1.0" w.g. (0 to 25.4mm w.g.)

Maximum Set Point Range

Minimum to 1.0" w.g. (0 to 25.4mm w.g.)

Reset Pressure Span

Field adjustable 0.0 to 10.0 psig (0.0 to .69 bar)

Main Air Pressure

15 to 30 psig (1.04 to 2.07 bar)

Air Consumption

1 scfh @ 20 psig (.472 l/min. @ 1.38 bar)



DESCRIPTION

THE CP101 RESET VELOCITY CONTROLLER PROVIDES PRESSURE INDEPENDENT OPERATION ON THE DPS / DPO8000 SERIES OF VARIABLE AIR VOLUME TERMINALS.

Each controller is equipped with separate adjustment knobs for minimum and maximum air flow settings. The minimum and maximum air flow settings are factory calibrated. However, they can be readjusted in the field if necessary. (See Page 9)

The CP101 is used for either direct or reverse acting thermostats and can be used for normally open or normally closed dampers. The CP101 has a factory set reset start point which can be field adjusted, and has a factory set reset span which can be field adjusted. The reset span is constant regardless of minimum and maximum set points.

Ambient Limits

<p>+40/+120°F operating (+4/+49°C) -40/+140°F shipping (-40/+60°C)</p>

Note: The controller should be supplied with clean, dry control air only. No attempt should be made to use any other medium.

Pneumatic Actuator Mounting Instructions

The DPS/DPO has been designed to accommodate several manufacturers' actuators for both normally open or normally closed fail-safe operation.

Figure 1 illustrates the standard actuator and linkage orientation for normally open units. Figure 2 illustrates the orientation of a normally closed unit.

If a change in the damper fail-safe position becomes necessary, the following procedure should be used.

1. Loosen the crank arm bolt (A) until the damper shaft rotates freely.
2. Remove the screws (B) securing the actuator mounting bracket to the terminal unit.
3. Relocate the actuator to the proper mounting holes as per Figure 3 and Table 1.
4. Ensure the actuator linkage is in the proper orientation as per Figure 1 or Figure 2. Install screws (B) securing actuator mounting bracket to the terminal.
5. Rotate the damper shaft until the damper is in the fail-safe position (full open or full closed) and tighten bolt on the crank arm (A)

Note: The illustrations are for right hand mounting only. The opposite orientation is required for left hand side mounting (Figure 1 normally closed, Figure 2 normally open).

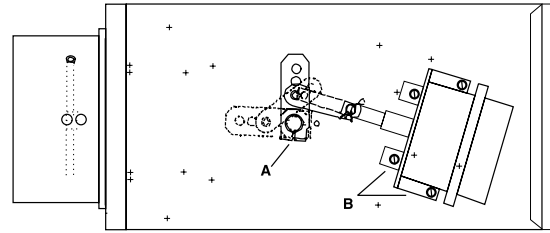

Figure 1 Normally Open Configuration

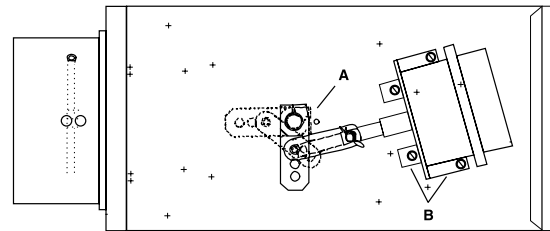

Figure 2 Normally Closed Configuration

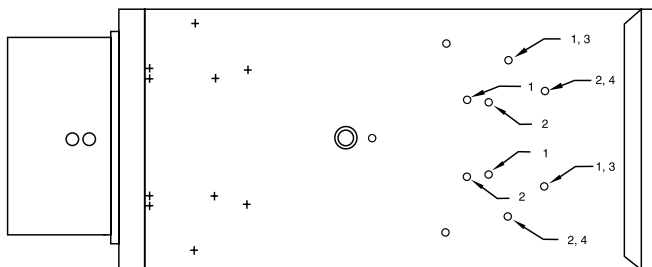

Figure 3

Table 1

Actuator Manufacturer	Damper Position	Mounting Holes
Johnson D3062	N.O.	4
Powers —	N.O.	4
Kreuter MCP-0305	N.O.	4
Kreuter MCP-8031-3102	N.O.	2
Honeywell MP909E1158	N.O.	4
Johnson D3062	N.C.	3
Powers —	N.C.	3
Kreuter MCP-0305	N.C.	3
Kreuter MCP-8031-3102	N.C.	1
Honeywell MP909E1158	N.C.	3

Pneumatic (CP101 Controller) Calibration Procedure

A. Damper Action

1. Damper action is factory set on the controller to either Normally Open or Normally Closed. To reset action, loosen damper selection switch screw and align desired action with damper arrow. Re-tighten screw.
2. Actuator must be repositioned to provide appropriate fail safe position. See page 8.

B. Reset Start Point

1. Reset start point is factory calibrated to the specified setting on the control assembly label.
2. To field adjust, remove the gauge port cap at "G" and attach a 0-30 psi pressure gauge.
3. Adjust the thermostat pressure at "T" port to the desired start point value with a gradual switch or pressure regulator. (Start point is the lowest span pressure.)
4. Adjust "Reset Start" dial until the gauge pressure begins to increase slightly (greater than zero but less than 0.3 psi).
5. Replace gauge port cap.

C. Reset Span

1. Reset span is factory calibrated to the specified setting on the control assembly label.
2. To field adjust, remove the gauge port cap at "G" and attach a 0-30 psi pressure gauge.
3. Adjust the thermostat pressure at "T" port to above 15 psi.
4. Adjust "Reset Span" dial until the gauge pressure is equal to the desired reset span (total span pressure, not end span pressure).
5. Replace gauge port cap.

D. Air Volume Limits

1. Remove the caps from the tees in the HI (red) and LO (green) tubes leading from the air flow sensor in the assembly inlet or downstream sensor. Connect a differential pressure gauge to the tees. A gauge with a 0 to 1 inch w.g. scale is recommended.
2. Refer to the calibration curve for the size of inlet and appropriate sensor (downstream or inlet). From the curve read the differential pressure for the required air flow.
Note:The downstream sensor is the same size as the largest inlet.
3. Alternately you can calculate the differential pressure from the equations provided on page 12.

E. Hot Deck Calibration (Constant Volume Operation)

1. For constant volume units, the controller that is connected to the downstream sensor will not have a thermostat line (usually the hot deck controller).
2. Turn the "HI STAT" dial to its maximum position (fully counter-clockwise). This will allow full calibration range on the "LO STAT" dial.
3. Adjust the "LO STAT" dial on the controller (center knob) until the gauge reads the required differential pressure for the total flow setting. Turn the dial slowly, allowing time for the damper actuator to complete its travel in response to the adjustments.
4. For calibration of the controller that is connected to the inlet sensor (usually the cold deck controller), set the thermostat to minimum cooling or disconnect the thermostat line from the controller.
5. See section G for cold deck calibration.

F. Hot Deck Calibration (Variable Volume Operation)

Note: The hot deck controller has a reset range of 3-8 psi. For readjustment, see sections B & C.

1. Set the hot deck controller first. Adjust thermostat to maximum heating or remove the thermostat line from the controller.
2. Adjust the "LO STAT" dial (center knob) on the hot deck controller until the gauge reads the differential pressure for maximum heating airflow. Turn the dial slowly, allowing time for the damper actuator to complete its travel in response to the adjustments.
3. If thermostat line was previously removed, then reconnect to the "T" port on the controller. Set the thermostat to minimum heating.
4. Adjust the "HI STAT" dial on the controller until the gauge reads the required differential pressure for the minimum mixing airflow. Turn the dial slowly, allowing time for the damper actuator to complete its travel in response to the adjustments.
5. Cycle the thermostat several times. This can be quickly accomplished by removing the cap from the gauge port "G" and varying the bleed rate with finger pressure. Replace cap and check the airflow limits. If set points change, readjust using the above steps.

G. Cold Deck Calibration (both Variable and Constant Volume Operation)

NOTE: The cold deck controller has a standard reset range of 8-13 psi and is calibrated for a direct acting thermostat. For readjustment see sections B & C.

6. Adjust the "LO STAT" dial on the controller (center knob) until the gauge reads the required differential pressure for the minimum cooling airflow (usually zero). Turn the dial slowly, allowing time for the damper actuator to complete its travel in response to the adjustments.
7. Connect the thermostat line, if previously disconnected, and set the thermostat to maximum cooling.
8. Adjust the "HI STAT" dial on the controller until the gauge reads the required differential pressure for the maximum cooling airflow. Turn the dial slowly, allowing time for the damper actuator to complete its travel in response to the adjustments.
9. Cycle the thermostat several times. This can be quickly accomplished by removing the cap from the gauge port "G" and varying the bleed rate with finger pressure. Replace cap and check the airflow limits. If set points change, readjust using the above steps.

H. General

1. Always adjust the "LO STAT" dial first. Adjustment of "LO STAT" dial directly affects "HI STAT" dial setting.
2. When measuring from downstream sensor gauge taps, ensure alternate deck is closed.
3. After calibration is complete, reconnect the thermostat tube to the controller if it has been removed during the calibration procedure.
4. Disconnect the gauge and replace the caps on the tees.
5. Replace the protective control cover.

Inlet Sensor Calibration Curves (see page 12 for equivalent calibration formulas)

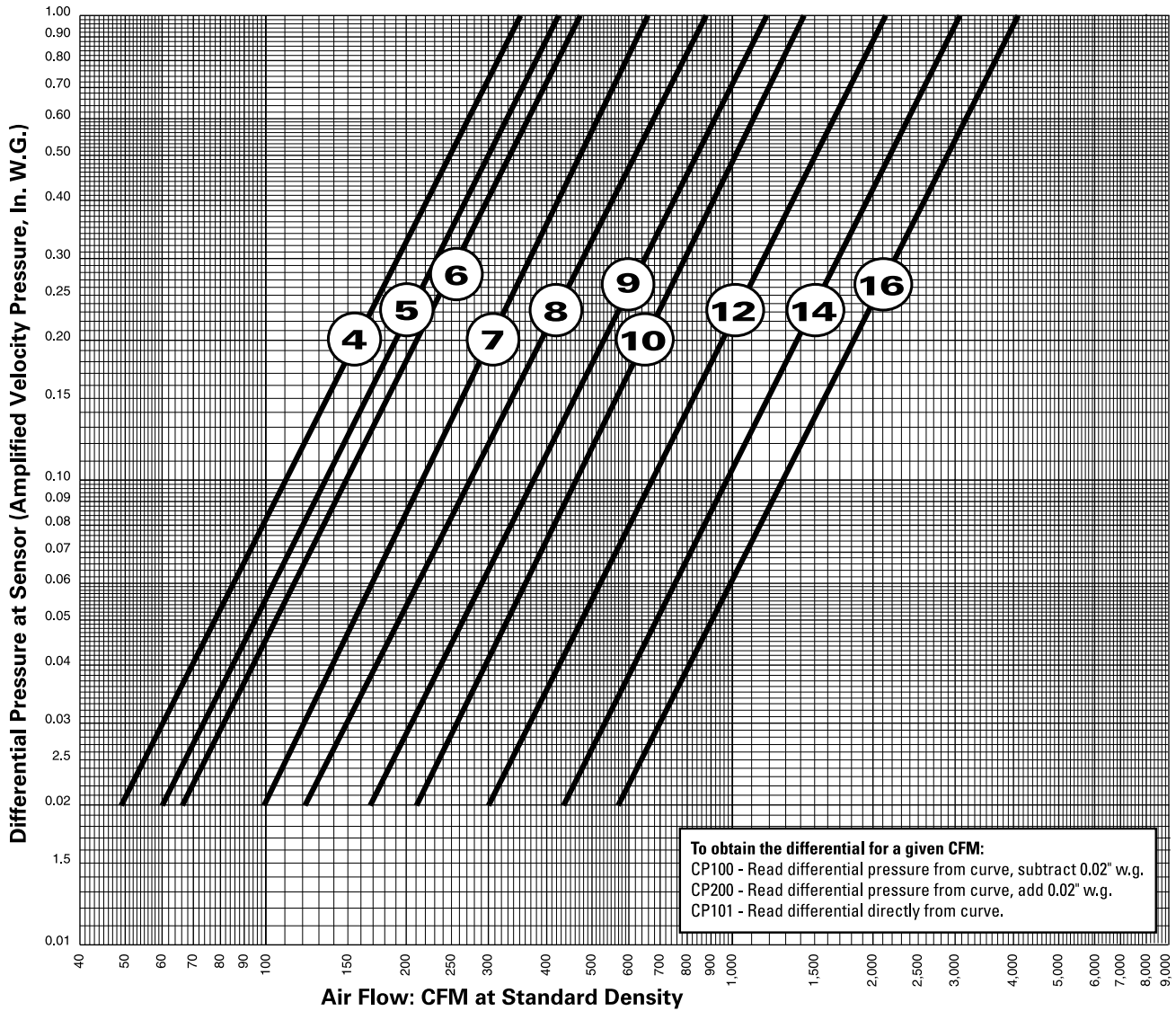

Downstream Sensor Calibration Curves (see page 12 for equivalent calibration formulas)

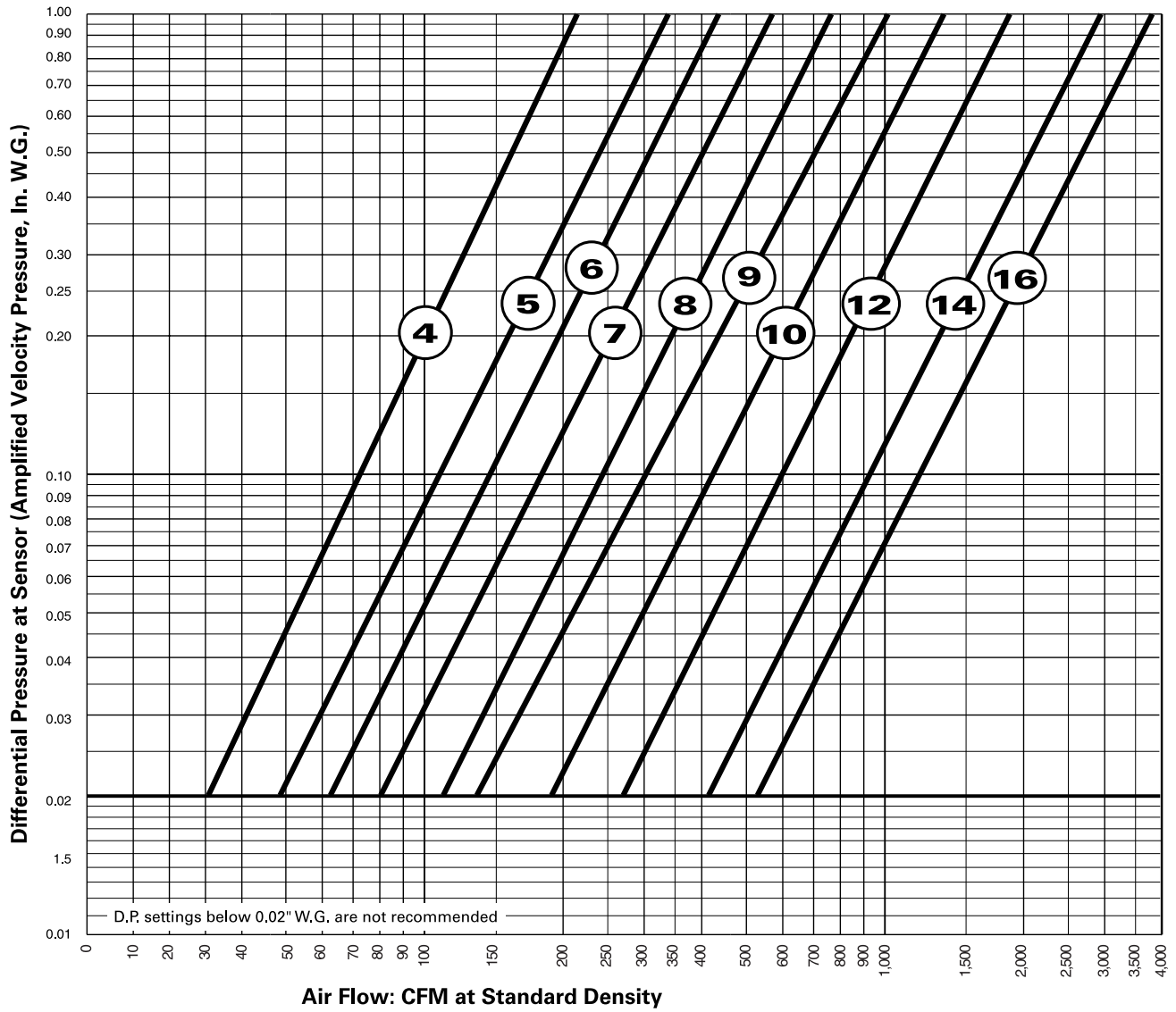

**Flow Sensor Calibration Equations
(for Pneumatic or DDC Controls)**

<p>CP101 $VP = \left(\frac{Q}{K}\right)^2$</p> <p>VP = differential pressure at sensor, inches w.g.</p> <p>Q = air flow rate, cfm at standard density</p> <p>K = calibration constant (K - factor)</p>	<table border="1"> <thead> <tr> <th colspan="2">Inlet Sensor</th> <th colspan="2">Downstream Sensor</th> </tr> <tr> <th>Unit Size</th> <th>K</th> <th>Unit Size</th> <th>K</th> </tr> </thead> <tbody> <tr><td>4</td><td>340</td><td>4</td><td>215</td></tr> <tr><td>5</td><td>426</td><td>5</td><td>340</td></tr> <tr><td>6</td><td>468</td><td>6</td><td>442</td></tr> <tr><td>7</td><td>673</td><td>7</td><td>588</td></tr> <tr><td>8</td><td>890</td><td>8</td><td>769</td></tr> <tr><td>9</td><td>1155</td><td>9</td><td>1004</td></tr> <tr><td>10</td><td>1487</td><td>10</td><td>1300</td></tr> <tr><td>12</td><td>2141</td><td>12</td><td>1890</td></tr> <tr><td>14</td><td>3050</td><td>14</td><td>2980</td></tr> <tr><td>16</td><td>4074</td><td>16</td><td>3679</td></tr> </tbody> </table>	Inlet Sensor		Downstream Sensor		Unit Size	K	Unit Size	K	4	340	4	215	5	426	5	340	6	468	6	442	7	673	7	588	8	890	8	769	9	1155	9	1004	10	1487	10	1300	12	2141	12	1890	14	3050	14	2980	16	4074	16	3679
Inlet Sensor		Downstream Sensor																																															
Unit Size	K	Unit Size	K																																														
4	340	4	215																																														
5	426	5	340																																														
6	468	6	442																																														
7	673	7	588																																														
8	890	8	769																																														
9	1155	9	1004																																														
10	1487	10	1300																																														
12	2141	12	1890																																														
14	3050	14	2980																																														
16	4074	16	3679																																														

Pneumatic Controls Parts List

Component	Part #	Description
Controller	076823-001	CP101 Pneumatic Controller
Actuators	076857-001	MCP-8031 Linear Actuator (5-10 psi)
	076838-001	MCP-3631 Rotary Actuator (5-10 psi)
	076827-001	MCP-0303 3" Stroke, Linear Actuator (5-10 psi)
	076827-002	MCP-0305 3" Stroke, Linear Actuator (8-13 psi)

Pneumatic Controls Troubleshooting Guide

<p>General</p>	<ol style="list-style-type: none"> 1. Locate thermostat and cycle — direct acting thermostat will bleed on heating. 2. Confirm box size and rating with drawing and box schedule (check label on terminal). Check position of controller to ensure it is installed level. 3. Check the damper selector switch at the face of the controller. Ensure that switch is set to correspond to damper's normal position. 4. Visually check piping and connections to box controls and motor. <ul style="list-style-type: none"> Blue — Main Air (M) White — Thermostat (T) Yellow — Actuator (B) Red — High Port (H) Green — Low Port (L) 5. Ensure caps are installed on tee fittings between sensor and controller. 6. Confirm main air pressure (15 psi minimum - 25 psi maximum). 7. Confirm thermostat pressure. Cycle thermostat from full cooling to full heating. 8. Confirm actuator pressure from controller by cycling thermostat. 9. Confirm actuator operation by stroking actuator with a hand pump noting at what pressure the actuator begins to stroke and is fully stroked.
<p>If Velocity Pressure is Below Specified Value and the Damper is Fully Open</p>	<ol style="list-style-type: none"> 1. Connect a differential pressure gauge (0 – 1.0" w.g.) to the tees in the sensor lines between the sensor and the controller. 2. Check velocity pressure reading and compare with the value indicated on the controller label. 3. If the velocity pressure is below the specified value and the damper is fully open, this would indicate insufficient inlet duct static pressure.
<p>If the Velocity Pressure Indicated by the Gauge Does Not Match the Specified Value.</p>	<ol style="list-style-type: none"> 1. If the damper of the control assembly is partially closed, this indicates the unit is under control. 2. If the velocity pressure indicated by the gauge does not match the specified value, recalibrate the controller according to the procedures outlined in this manual.
<p>If Supply Air Flow Measured by Other Means is Incorrect</p>	<ol style="list-style-type: none"> 1. If the supply air flow measured by other means (pitot tube traverse, summation of outlets) is incorrect inspect the inlet connection to the control assembly. 2. Price recommends a minimum of 3 duct diameters of straight inlet duct, same size as inlet between the inlet and any transition, take off or fitting.
<p>If Velocity Pressure Indicated by the Gauge is Lower than Specified but Actual Air Supply Exceeds Design Flow.</p>	<ul style="list-style-type: none"> • Check the high pressure tubing connection on the sensor to see if tubing is connected properly. • The HI sensor port or control line may be plugged. Remove tubing and clear the passage with compressed air.
<p>If the Damper Remains Fully Open, but Sufficient Static Pressure Exists at the Inlet</p>	<ul style="list-style-type: none"> • Confirm main air pressure (15 psi minimum - 25 psi maximum) • The LO sensor port or control line may be plugged. Remove tubing and clear the passage with compressed air.
<p>If the Damper Remains Fully Closed</p>	<ul style="list-style-type: none"> • Confirm main air pressure (15 psi minimum to 25 psi maximum)

Electronic Controls Section

CSP-5001 VAV Flow Controller-Actuator, Electronic Analog

MADE IN U.S.A.

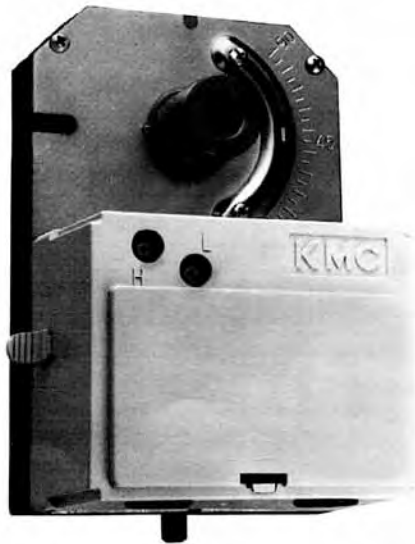

CALIBRATION:

VNOM: The CSP range is factory calibrated to provide a 10.0 VDC signal at the maximum rated airflow for a given box size. Changing the VNOM adjustment allows matching 0 to 10 volt output to a specific CFM range.

To adjust the VNOM setting start by connecting a DC voltmeter to the (OUT) and (-) terminals on the controller. With the unit powered up, run the desired maximum air flow through the box and verify using a pitot tube traverse or other suitable method. Allow several minutes for the controller output to stabilize. Once the reading is stable, readjust the VNOM dial until the voltmeter reads 10.0 VDC +/-0.1 volt. Check to make sure the setting does not drift excessively and readjust if necessary.

NOTE: If VNOM is reset, the thermostat output voltages for min and max flow will have to be changed to match the new control range. Calculate the new thermostat voltages using the following equation:

$$\text{DC Volts} = \text{Desired CFM} / (\text{CFM used to set VNOM} \times 0.1)$$

VELOCITY LIMITS: For velocity limits at the thermostat set controller MIN full CCW and MAX full CW. To adjust limits at the CSP, connect a voltmeter to the meter taps. Move the jumper from the NOR position to the MIN position. Adjust the min adj. for the desired voltage. Note: MIN must be adjusted first. Move the jumper to the MAX position and adjust the MAX voltage. Return the jumper to the NOR position.

NOTE: Price standard is with velocity adjustment at thermostat.

Maintenance

The selection of materials has been made with long term and dependable operation in mind.

Strict adherence to installation methods will enhance the performance of these controls.

DESCRIPTION

The CSP-5001 is a pressure-independent, controller-actuator designed primarily for use on variable air volume terminal units.

The CSP-5001 offers full range flow control of VAV terminal units when used with the CTE-5100 series room thermostats. The actuator section provides adjustable stops, magnetic clutch and a gear disengagement button. A tri-color LED indicates green for opening, red for closing and white for satisfied damper positions.

SPECIFICATIONS

Supply Voltage	24VAC, -15%/+20%, 50/60Hz
Input Power	4VA
Output Supply	16VDC (22mA)
Output Torque	50 in. lb. min., 70 in. lb. max. (5.6 Nm min., 7.9 Nm max.)
Velocity Range	0 to 3,300 fpm (16.76 m/s), dependent on SP pick-up, tubing size/length and connections
Velocity Output	0 to 10VDC (0 to 100% flow) VNOM adj. to box size
Reset Voltage	0 to 10VDC
Reset Limits	Adjustable 0 to 100%
Connections	Wire clamp type; 14 to 22AWG Cu
Angular Rotation	0 to 95°, both end stops adjustable
Stroke Time	18° / minute @ 60 Hz
Mount	Direct to 1/2" (13mm) dia. shaft or 3/8" (10mm) dia. with adaptor
Material	Flame retardant polymer; UL94-5V plenum rated; blue housing with white cover
Weight	2.4 lb. (1 kg)
Ambient Limits	Operating 32° to 120°F (0° to 49°C) Shipping -40° to 140°F (-40° to 60°C)

SCREW TERMINALS

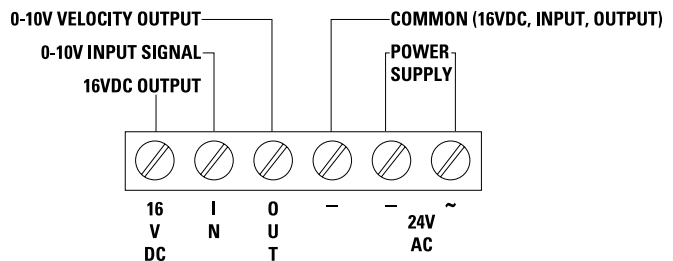

Electronic Controller/Actuator Mounting Instructions

In the event that it is necessary to replace the controller/actuator due to defect or damage, the following procedure should be used.

1. **Disconnect the power to the unit prior to any work.**
2. Disconnect the wires on the terminals and note or tag wires for proper reinstallation.
3. Loosen the two set screws located in the shaft collar.
4. Remove the controller/actuator from the DES / DEQ 8000 assembly by slipping it off of the damper shaft.
5. Remove the sensor lines from the ΔP ports. Use caution not to damage the ports with excessive force.

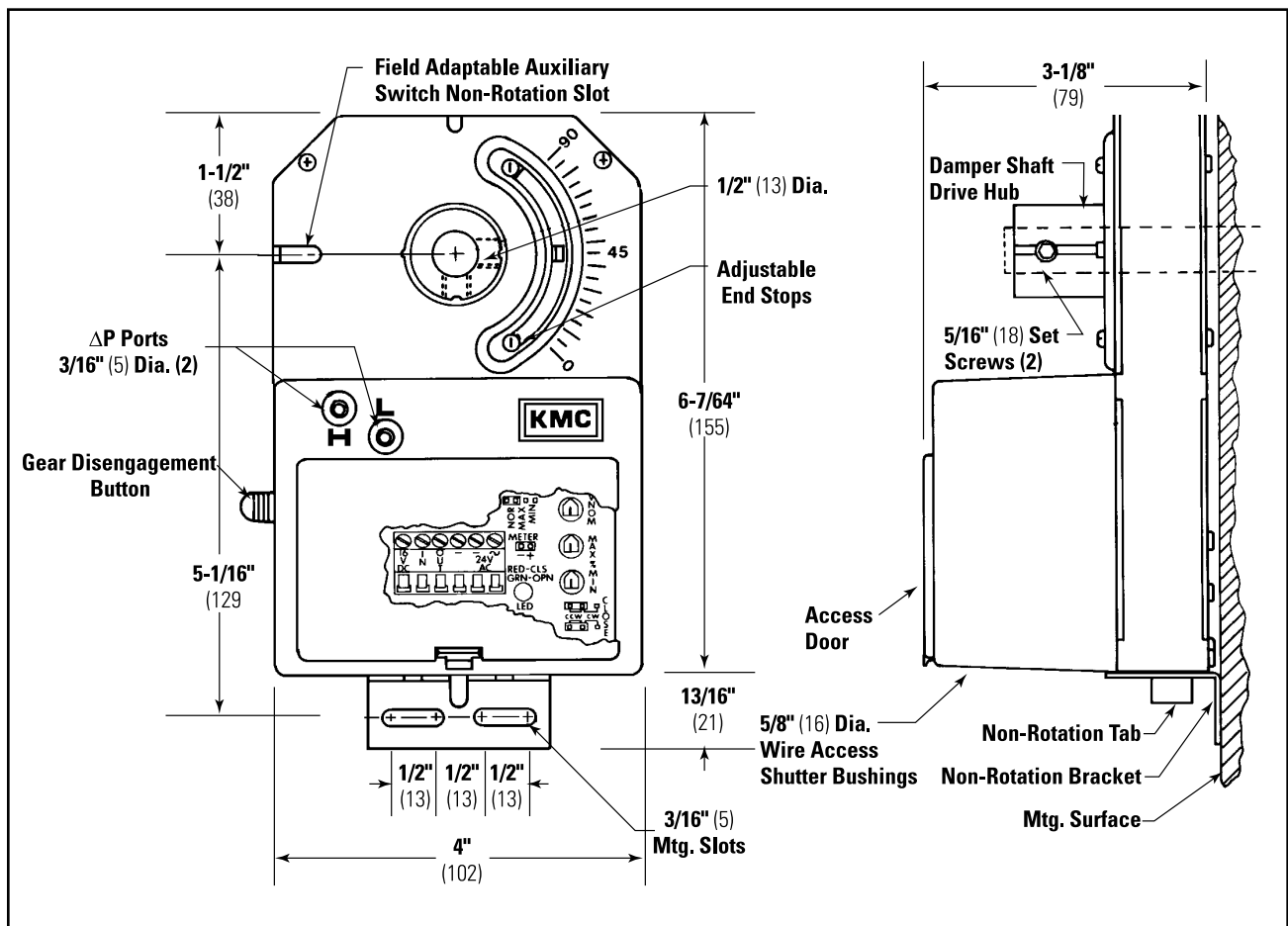

To install a new controller/actuator, the following procedure should be used.

1. Close the DES/DEQ 8000 damper prior to installing the new controller/actuator. The end of the damper shaft is marked with a groove indicating damper orientation. Ensure it is perpendicular to the airflow.
2. Slip the new controller/actuator over the damper shaft and slide it into the original bracket.
3. Depress the Gear Disengagement button and rotate the Drive Hub fully counter-clockwise.
4. At this point verify again that the damper is closed and then tighten the damper shaft collar set screws.
5. Reconnect the wires and verify with the wiring diagram on the unit.
6. Reconnect the sensor lines to the ΔP ports.
7. Calibrate the controller/ actuator if not factory calibrated. See calibration instructions on Page 14.

Electronic Controls

CTE-5100 Series VAV Flow Controller-Actuator, Electronic Analog

MADE IN U.S.A.



MODELS

CTE-5101	Single setpoint; direct acting
CTE-5102	Single setpoint; reverse acting
CTE-5103	Dual setpoint; direct & reverse acting
CTE-5104	Dual setpoint; direct & reverse acting
CTE-5105	Dual setpoint; both direct acting

ACCESSORIES

HFO-0027	Setpoint stops
HMO-5023	Drywall mounting kit
HMO-5030	Almond back plate (Standard)
HMO-5031	White back plate
HPO-0060-10	Horizontal Scale plate °F (Standard)
HPO-0060-11	Horizontal Scale plate °C (Standard)
HPO-0061-10	Vertical scale plate °F
HPO-0061-11	Vertical scale plate °C

ABS Covers

HPO-1501	Blank; almond color
HPO-1502	Blank; white color
HPO-1511	Window; almond color (Standard)
HPO-1512	Window; white color

DESCRIPTION

The CTE-5100 series is designed to be used with the CSP-5001 FLOW Controller-Actuator and/or the REE-1000/4000 series auxiliary relays. CTE-5100's are provided with limited and unlimited outputs. The limited output(s) is (are) used to provide minimum and maximum limits to a CSP-5001.

The standard thermostat used for DES / DEQ units is model CTE-5103.

SPECIFICATIONS

Supply Voltage	16VDC (14-20VDC)
Output Range	0 to 10VDC
Connections	Wire clamp type; 14-22 AWG
Proportional Band	
CTE-5101/2/3/5	2°F (1.1°C) w/ limits output (T1/T2) 2°F (1.1°C) w/o limits output (T1/T4)
CTE-5104	2°F (1.1°C) w/ & w/o limits output (T1/T2/T3)
Thermostat Action	
CTE-5101	Direct Acting (DA) T1/T3
CTE-5102	Reverse Acting (RA) T2/T4
CTE-5103	Direct Acting (DA) T1/T3 Reverse Acting (RA) T2/T4
CTE-5104	Direct Acting (DA) T1/T3 Reverse Acting (RA) T2
CTE-5105	Direct Acting (DA) T1/T2/T3/T4
Base Material	Black ABS
Size	2-9/16" (65mm) x 3-7/16" (87mm)
Ambient Limits	
Operating	40°F to 120°F (40°C to 49°C)
Shipping	-40°F to 140°F (-40°C to 60°C)

**CTE-5100
Thermostat Accessories**

MADE IN U.S.A.

MOUNTING HARDWARE

Thermostats may be mounted with this backplate to a 2" x 4" electrical box. Available in two finishes and supplied with two 6-32 screws and decorative aluminum plate.

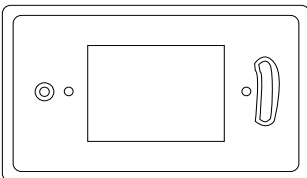

Secure backplate which is slotted for levelling to box with 6-32 screws. Connect wiring as described on the control diagram. With cover removed, mount thermostat (supplied with 6-20x2" screws) to backplate.

HMO-5023 Drywall Mounting Kit

Thermostats may be mounted to a hollow wall up to 5/8" thick using this bracket. Kit includes bracket, two 6-32x2" screws, and template for a precise 1 1/2" x 2 11/16" wall cutout.

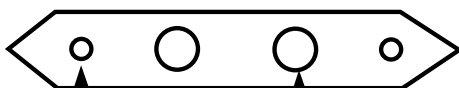

Mounting Holes (2)

Wire/Cable Access Holes (2)

Loosely mount thermostat (cover removed) to the bracket with 6-32x2" screws. Connect wiring as described on thermostat data sheet. Insert the bracket through the wall cutout diagonally, centre, and tighten screws.

WINDOW COVER

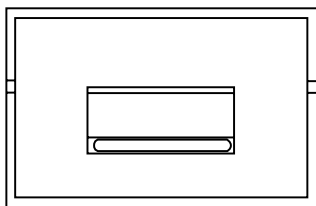

Covers are available in 2 styles and a variety of decorative finishes. A symbol-coded label strip is included with the window-styled covers for setpoint indication.

Remove window by applying finger pressure on the underside centre of window and flex outward, releasing from either side. Peel-off and stick desired label into indented area, making sure symbols are on correct sides. Snap window back into place.

Be sure scale plate and other accessories are in place and slide cover over base. Locate both set screws through sides and with a 1/16" hex wrench, turn screws outward (CCW) until cover is held firmly in place. To remove cover, turn screws inward (CW) to provide clearance for lifting off.

SCALE PLATE

Scale Plates are available in vertical and horizontal styles, °F and °C.

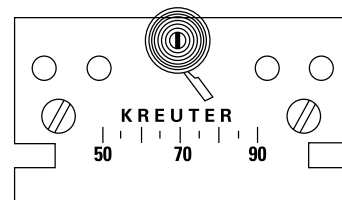

Custom names / finishes on request.

Two retaining pins are supplied with each scale plate. Slide the plate under the setpoint slide indicator(s) and align. Insert retaining pins into the holes and twist to lock in place. Replace cover. If no temperature indication is desired, turn the thermometer out of view before installing cover.

- HPO-0046 Retaining Pin
- HPO-0060-10 Horizontal Scale Plate °F
- HPO-0061-10 Vertical Scale Plate °F
- HPO-0060-11 Horizontal Scale Plate °C
- HPO-0061-11 Vertical Scale Plate °C

HPO 0046

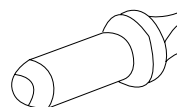

HPO 1320

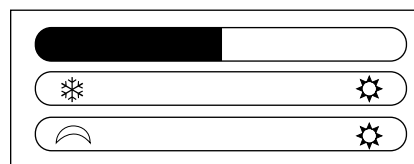

Blue / Red

Winter / Summer

Night / Day

SETPOINT STOPS

Setpoint can be locked or limited using these break-apart stops. Set includes four. Stops are inaccessible and hidden when cover is installed.

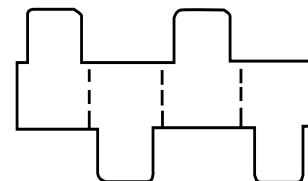

Using pliers, gently grip both sides of a seam and fold to break apart each stop. Insert a stop into the slider track on one or both sides of slider.

HFO-0027 Setpoint Stop Strip

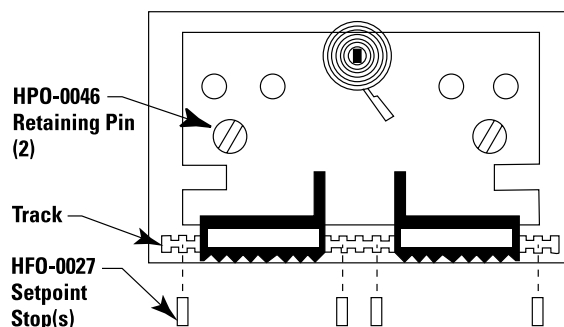

Electronic Thermostat Installation / Calibration

Thermostats may be mounted horizontal or vertical utilizing the HMO-5030/5031 back plates for mounting to standard 2"x4" electrical box, or the HMO-5023 drywall bracket for mounting to hollow walls. Thermostats should be mounted on a wall in an area unaffected by sunlight or drafts, to sense the average room temperature.

Electrical Box Mounting: Install the HMO-5030 / 5031 back plate to the electrical box using the two 6-32 screws (supplied with back plate). Do not tighten: the back plate is provided with one slotted mounting hole for levelling. Level the back plate and tighten the two mounting screws. Pull all thermostat wires, cable through the back plate and the decorative trim plate opening (supplied with HMO-5030 / 5031). Be careful not to damage the trim plate while wiring. The trim plate will be held in place once the thermostat is mounted to the back plate. Connect the thermostat's wires according to its particular application. Refer to the Control Diagram for wiring details. Position the trim plate between the back plate and thermostat, align the mounting holes and secure the assembly with the two 6-32x2" self-tapping screws supplied.

Hollow Wall Mounting: Loosely mount the HMO-5023 bracket to the thermostat using the two 6-32x2" screws. Pull all thermostat wires or cable through the bracket's wiring/cable hole. Connect thermostat wires according to its particular application. Refer to the project Control Diagram for wiring details. Insert the bracket diagonally through the 1.5" x 2.69" wall cutout. Centre and align the thermostat while tightening the mounting screws.

Scale Plates: Install the scale plate to the thermostat

with the two HPO-0046 retaining pins supplied with scale plate. Slide the scale plate under setpoint indicator(s), and align the mounting holes. Insert the retaining pins into the holes and twist 1/4 turn to firmly seat the pins.

Setpoint Stops: If required, install HFO-0027 setpoint stop (optional). Each setpoint slider may be locked in place or have limited adjustment range by using two stops. Four stops are supplied on a strip and easily pulled apart by gently using pliers. Insert one stop crosswise into the slider track at the exact position for stopping the setpoint slider on one or both sides. After all accessories are installed, slide cover onto base and locate both set screws on the short side. With a 1/16" hex/key wrench, turn set screws outward CCW until the cover is held securely in place. Turn set screws CW for sufficient clearance to remove cover.

Maintenance

Design and material of all components assures dependable long term reliability and performance. Careful installation will enhance operation and no routine maintenance is required.

Wiring: Thermostat Terminals:	5101	5102	5103/5105	5104	Description
V1	X		X	X	Velocity input for read-out.
T3	X		X	X	Upper setpoint output w/o limits.
R1	X		X	X	T1 override, connect to "." if unused.
T1	X		X	X	Upper setpoint output w/ limits.
+	X	X	X	X	16VDC power supply input.
12V	X	X	X	X	12VDC power supply.
A	X	X	X	X	Temperature averaging input.
-	X	X	X	X	Ground reference
T2		X	X	X	Lower setpoint output w/ limits.*
R2		X	X	X	T2 override, connect to "." if unused.*
T4		X	X		Lower setpoint output w/o limits.
V2		X	X		Velocity input for read-out.

*Except 5104; T2, lower setpoint output is w/o limits. R2 is auxiliary limit trigger, voltage above 1VDC @ R2 indexes T1 to the auxiliary flow limit.

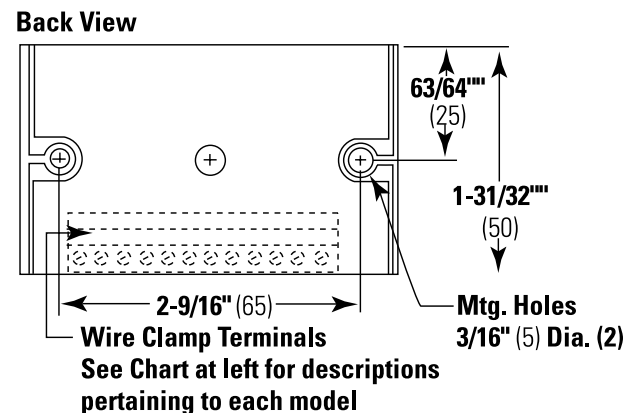
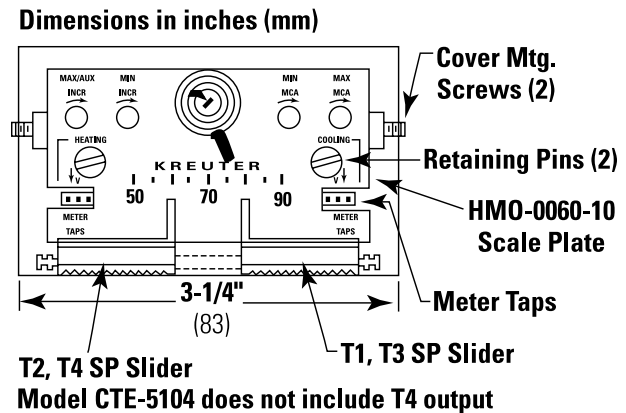

Air Flow Adjustment Procedure

In order to correct for poor inlet conditions (which cause inaccurate airflow sensing) or changing design parameters, it may be necessary to adjust the factory set minimum and maximum air flow rates in the field. These adjustments are performed at the wall mounted thermostat. In the event that inlet conditions to the terminal are causing the inaccuracies, the calibration curves referred to in the procedures will no longer be valid. In this case either duct traverses or air outlet measurements will be required to establish true air volumes.

Calibration Procedure for Velocity Adjustments Made at Thermostat

Required Tools:

1. Small flat blade (1/8") screwdriver.
2. Digital voltmeter capable of displaying a 0 to 10 VDC range which will display in .01VDC increments.
3. Calibration test leads (P/N 019069-001).

Remove Thermostat Cover

Thermostat cover is removed by releasing the mounting screws on either side of the cover.

A. General

1. Be certain the ambient room temperature at the thermostat is within the range of the thermostat (55° F to 85° F) (13° C to 29° C).
2. For the cold deck, connect a digital voltmeter to the meter taps on the cooling side of the thermostat (1) (fig. 2) using Calibration test leads (see fig.1).
3. Adjust the cooling set point slider all the way to the right for minimum cooling. Read the DC voltage across the meter taps.
4. Adjust the minimum set point (MIN INCR) potentiometer (3) to the desired DC voltage. The DC voltage may be determined from the calibration curves or by direct air flow measurement. See calibration curves on page 20.

Note: The minimum set point must be adjusted first. Adjustment of the MIN INCR potentiometer directly affects the maximum set point.

5. Adjust the cooling set point slider all the way to the left for maximum cooling. Read the DC voltage across the meter taps.
6. Adjust the maximum set point (MAX INCR) potentiometer (4) to the DC voltage equivalent for the desired airflow.

Note: For constant volume calibration see section B and for variable volume calibration see section C.

B. Constant Volume Application

7. Connect the meter taps to the heating side of the thermostat (7) (fig. 2).
8. Adjust the heating set point slider all the way to the left for minimum heating. Read the DC voltage across the meter taps.
9. Adjust the minimum set point (MIN INCR) potentiometer (5) to the DC voltage required for the TOTAL airflow set point.
10. Adjust the heating set point slider all the way to the right for maximum heating. Read the DC voltage across the meter taps.
11. Adjust the maximum set point (MAX INCR) potentiometer (6) to the desired DC voltage equivalent to the TOTAL airflow set point.

Fig. 1
Test leads and meter hook up

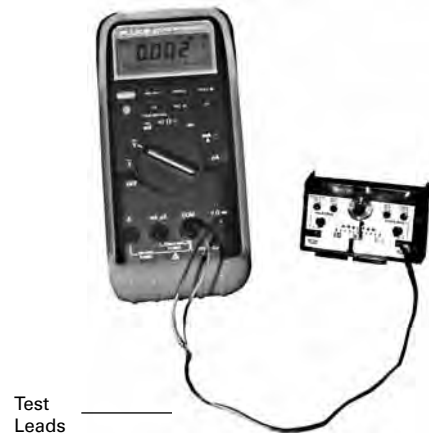

Note: For Constant Volume application, the minimum and maximum heating set points must have the same DC voltage setting.

12. Return the set point sliders to the desired set point. Insert set point slider stops if required. Replace the thermostat cover.

C. Variable Volume Application

7. Connect the meter taps to the heating side of the thermostats (7) (fig. 2).
8. Adjust the heating set point slider all the way to the left for minimum heating. Read the DC voltage across the meter taps.
9. Adjust the minimum set point (MIN INCR) potentiometer (5) to the DC voltage required for the MINIMUM MIXING airflow set point.

Note: For Variable Volume applications, the minimum heating set point should be set equal to the DC voltage for the minimum mixing airflow.

10. Adjust the heating set point slider all the way to the right for maximum heating. Read the DC voltage across the meter taps.
11. Adjust the maximum set point (MAX INCR) potentiometer (6) to the desired DC voltage equivalent for the maximum airflow set point.
12. Return the set point sliders to the desired set point. Insert set point slider stops if required. Replace the thermostat cover.

Fig. 2
CTE-5103

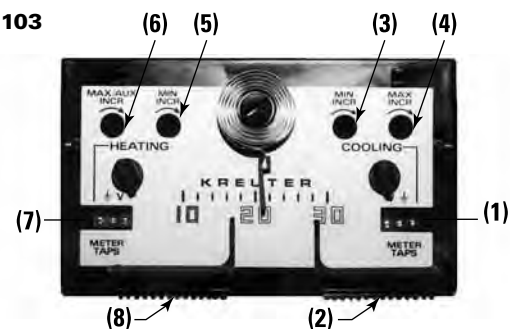

Electronic Thermostat Calibration Curves (see page 21 for equivalent formulas)

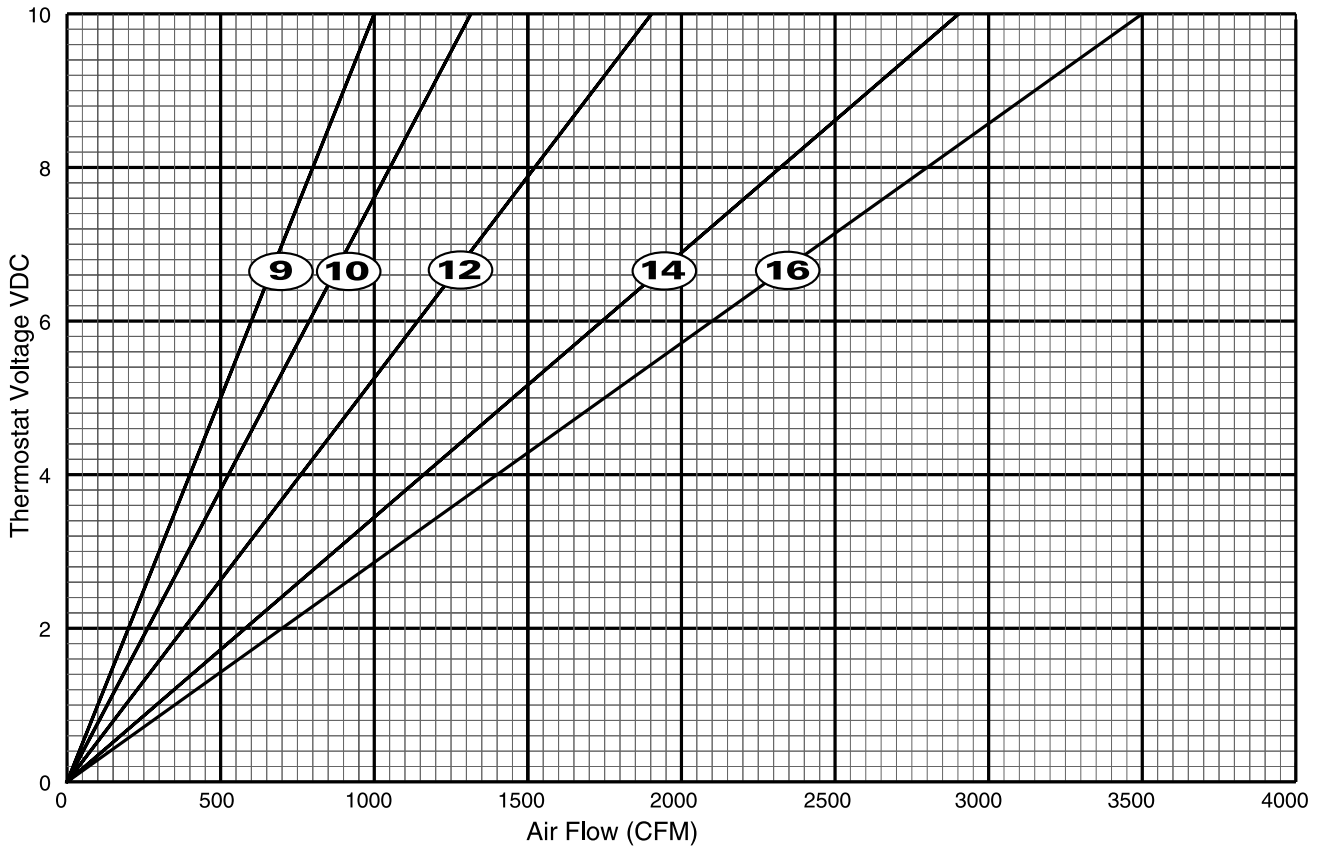
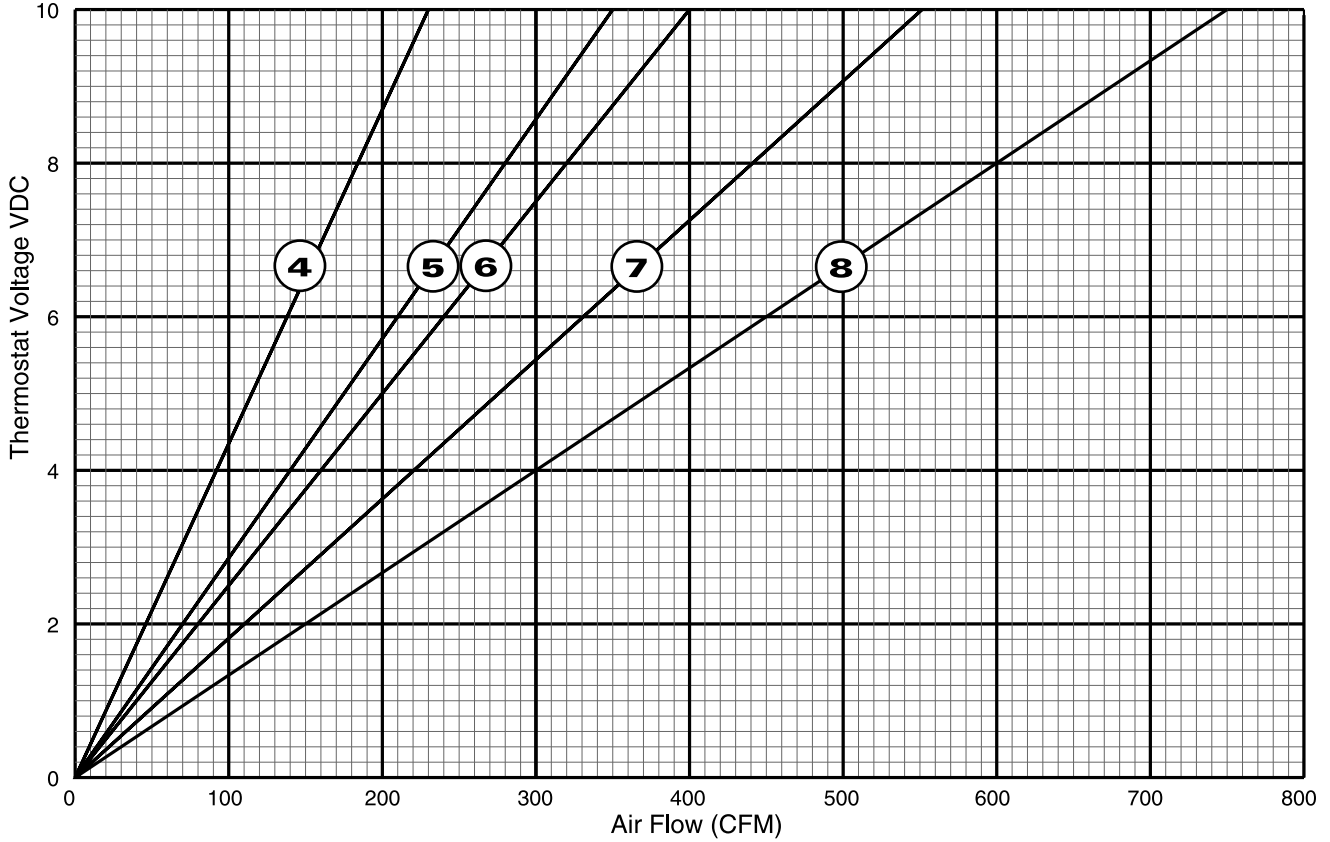

Electronic Calibration Equations

Size	Equation	Size	Equation
4	VDC = CFM / 22.5	9	VDC = CFM / 100
5	VDC = CFM / 35	10	VDC = CFM / 130
6	VDC = CFM / 40	12	VDC = CFM / 190
7	VDC = CFM / 55	14	VDC = CFM / 290
8	VDC = CFM / 75	16	VDC = CFM / 350

Electronic Controls Parts List

Component	Part #	Description
Controller	019345-001	CSP-5001 Controller/Actuator
Thermostat	019723-001	CTE-5103 Dual Setpoint, Direct & Reverse Acting
Transformers	019436-004	120-24 VAC; 20 VA Foot-Mounted Transformer
	019436-001	120-24 VAC; 50 VA Foot-Mounted Transformer
Test Leads	019069-001	Calibration Test Leads

Electronic Controls Troubleshooting Guide

While this manual is a troubleshooting guide for dual duct electronic terminal units it does not cover all the possible problems that may exist and some of the tests are based on the premise that the central air system is capable of supplying the terminal unit with the requested air flow. The following is a recommended step by step procedure for troubleshooting dual duct electronic terminal units.

<p>General</p>	<ol style="list-style-type: none"> 1. Locate the box in question and remove the shroud cover. Verify the wiring is correct for the application and control devices installed. Be certain all wiring terminations are tight and that there are no broken wires. Correct the wiring according to the control diagram found on the inside of the shroud cover if necessary. 2. Verify the supply voltage is between 20 VAC and 28.8 VAC volts. 3. Verify the cross flow sensor tubing for correct plumbing and tightness. No bends or kinks should be allowed. Do not alter the length of the tubing as a specific length with one brass elbow is required to maintain a specific flow across the sensor. 4. Check damper/actuator shaft for movement. The shaft should be movable when the actuator clutch is depressed and static when the clutch is released. Clutch will not release gears if driven against either end stop 5. Check DC voltage setting against the factory settings.
<p>Air Volume Not As Specified</p>	<ol style="list-style-type: none"> 1. Locate the box in question and remove the cover. Verify the tagging matches the tagging on the terminal unit. Attach a digital voltmeter to the meter taps on the face of the thermostat or at the controller. 2. Verify the voltage output (DC volts) matches the flow settings on the label. 3. If the minimum and maximum air flow settings do not correspond to the factory calibrated settings then recalibrate the thermostat (see airflow adjustment procedures). 4. Verify the Controller/Actuator is capable of positioning the damper through its 90 degree travel from fully open to fully closed. Depress the clutch engagement button and rotate the damper through its rotation. If the damper is already at fully open or fully closed the clutch button may not depress. If the damper is fully closed adjust the thermostat to maximum. As the damper begins to open the clutch button may be depressed. If the damper is fully open move the thermostat to minimum. As the damper begins to close the clutch button may be depressed. Release the clutch button to allow the Controller/Actuator to resume modulating the damper. 5. If the Controller/Actuator does not position the damper accordingly check for the following: <ol style="list-style-type: none"> a. Upstream velocities exceeding 3300 fpm. b. Mechanical stops limiting the travel of the damper in either direction. c. Binding of the damper blade or damper shaft preventing travel in either direction. 6. Check inlet configuration. Price recommends 3 duct diameters of straight inlet duct, same size as the inlet, between the inlet and any transition, take-off, or fitting. If a poor inlet condition is present, voltage setting may not be valid. A duct traverse may be necessary to achieve accurate settings.



PRICE
INDUSTRIES

2975 Shawnee Ridge Court
Suwanee, Georgia USA 30024
Ph: 770.623.8050 Fax: 770.623.6404



PRICE
INDUSTRIES

1290 Barrow Industrial Parkway
Auburn, Georgia USA 30011



PRICE
INDUSTRIES

999 North Thornton Road
Casa Grande, Arizona USA 85222-3809



e.h. price
LIMITED

638 Raleigh Street
Winnipeg, Manitoba Canada R2K 3Z9
Ph: 204.669.4220 Fax: 204.663.2715

The founding principles of our company have never changed - business integrity, first class service and a commitment to people. Price manufacturing endeavors arose from our belief that we could supply superior products and services at a reasonable price. Our mission is to become the world-wide supplier of preference for air distribution products and services. You can rely on Price – our products and services – with confidence.

Warranty: The Company warrants and guarantees that all goods within this catalog that have been manufactured by the Company have been manufactured in accordance with the specifications published herein and will be free from defects in material and workmanship for a period of twelve (12) months from the date of Bill of Lading issued by the Company. The Company will replace defective product at its option, but will not be responsible for labor or material charges in replacing product or consequential damages. Any installation not conforming with the Company's specifications, manuals, bulletins or instructions or any misuse or any modification not authorized by the Company voids this warranty. This warranty is in lieu of all Provincial, State, and Federal statutory warranties and the conditions herein are in substitution and replacement of such warranties, statutory or otherwise.

Your Local Price Representative:

Grilles & Diffusers

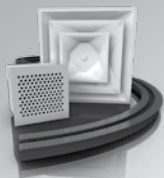

Critical Environments

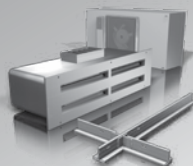

Terminals

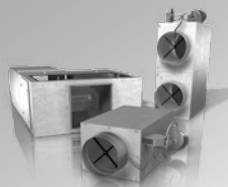

Sustainable Building



Noise Control

