

SDVQ 5000
SINGLE DUCT QUIET TERMINAL
VARIABLE VOLUME CONTROL
c/w DIRECT DIGITAL CONTROLS
INSTALLATION MANUAL

Date: 04/11
Reference #: F-33

SDVQ 5000

General Description

The SDVQ 5000 assembly is designed to accept direct digital controls (DDC) for VAV pressure independent operation.

The terminal unit controls are supplied by the controls contractor and either factory or field mounted and wired. For information concerning controls, components, sequence of operation, etc., please refer to the documentation provided by the controls contractor.

Receiving Inspection

After unpacking the assembly, check it for shipping damage. If any shipping damage is found, report it immediately to the delivering carrier. During unpacking and installation do not handle by the inlet velocity sensor, damper shaft, or tubing. Damage may result.

Wiring

If controls have been factory mounted, a wiring diagram will be included with the unit indicating the factory mounted components. For field wiring of room sensors and other accessories, refer to the controls contractor's documentation. If the controls have been field mounted, refer to the controls contractor's documentation for all wiring information.

Installing the SDVQ 5000 Terminal Unit

Use the support method prescribed for the rectangular duct in the job specifications. A set of hanger brackets (HB) could be ordered from the factory and could be used as per drawing below.

Important: For optimum performance there should be a minimum of three duct diameters of straight inlet duct, **same size as the inlet**, between the inlet and any transition, take off or fitting.

The assembly should be mounted right side up. It should be level within ± 10 degrees of horizontal, both parallel to the air flow and at right angles to the air flow. The side of the assembly is labelled with an arrow indicating UP. Do not mount the control side of the assembly tight to a wall, pipe or other obstruction. Allow sufficient room for access to the controls.

To prevent excess air leakage, all joints should be sealed with an approved duct sealer. This would apply to all accessory module connections as well as the basic assembly.

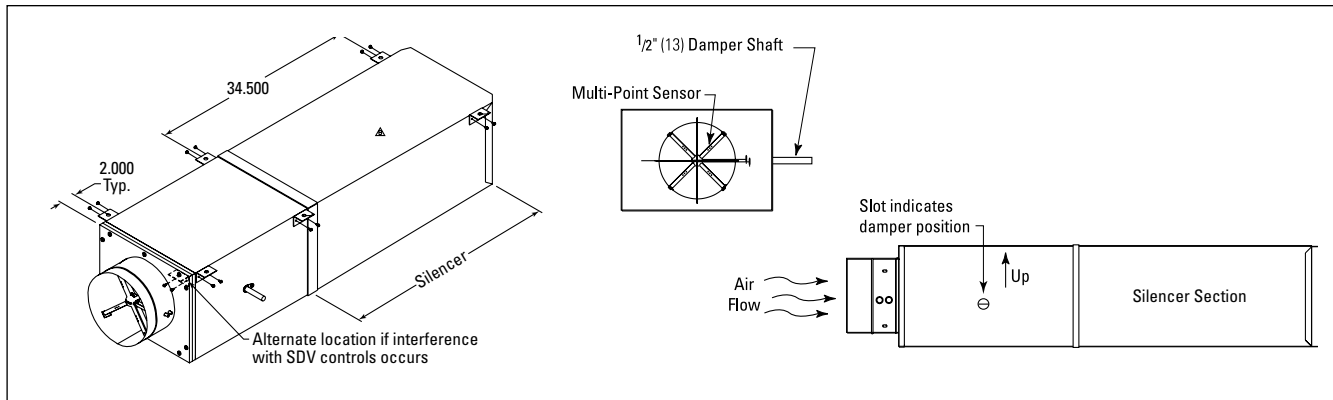

Damper rotation is always clockwise to the open position. An identification mark on the end of the shaft indicates the damper position.

The factory supplied sensing lines are color coded. Red indicates the total pressure or "HI" line which should be located on the upstream side. Green indicates the static pressure or "LO" line which should be located on the downstream side.

An optional protective enclosure may be provided to house the terminal unit control components. The enclosure cover is removable with two sheet metal screws.

The velocity sensor is normally supplied as standard with the terminal unit. However, in some cases a flow sensing device supplied by the controls contractor may be factory or field mounted. Refer to the submittal drawing for illustration.

The air volume ranges listed are recommended for optimum performance. A minimum value of zero is also acceptable if no heating coils are attached.

Selection of air flow limits below the listed values is not recommended. Stability and accuracy may not be acceptable at lower than recommended air flow limits. The actual performance will vary depending on the terminal unit controls supplied.

Air Volume Ranges

Unit Size	CFM	L/S
	Min. - Max	Min. - Max
4	50 - 225	24 - 106
5	63 - 350	30 - 65
6	66 - 450	31 - 212
7	99 - 650	47 - 307
8	132 - 800	62 - 378
9	167 - 1050	79 - 496
10	221 - 1350	104 - 637
12	304 - 2100	143 - 991
14	439 - 3000	207 - 1416
16	568 - 4000	268 - 1888
24 x 16	1187 - 8000	500 - 3776

Notes:

Factory calibrated controls must be selected within the above flow range limits. A minimum value of zero is also available. When an auxiliary flow setting is specified, the value must be greater than the minimum setting and within the range limits.

On controls mounted by Price but supplied by others, the air volume ranges are guidelines only.

Selection of air flow limits below the listed values is not recommended. Stability and accuracy may not be acceptable at lower than recommended air flow limits. The actual performance will vary depending on the terminal unit controls supplied.

SP300 Calibration Curves

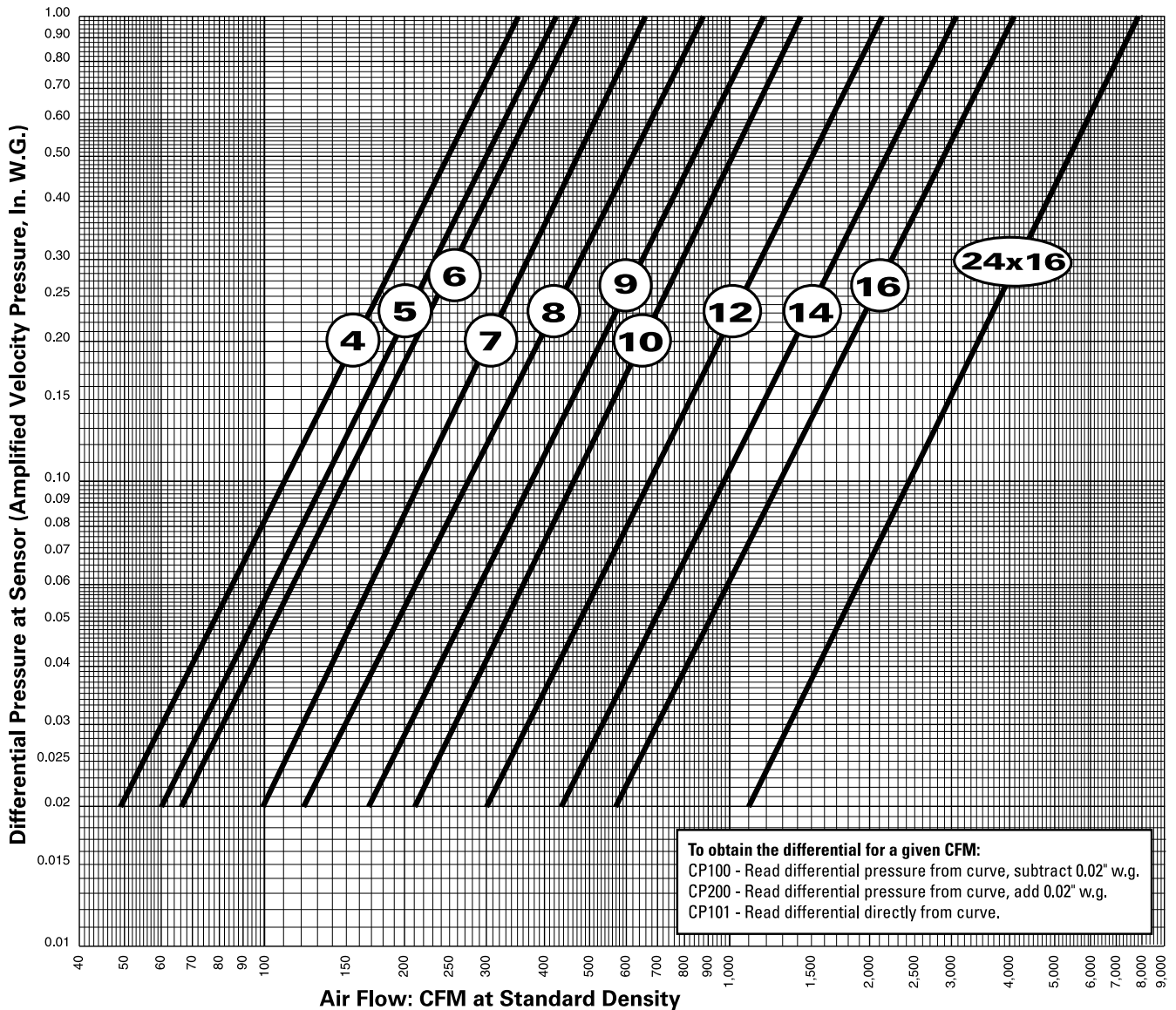

Calibration Equation

$$VP = \left(\frac{Q}{K}\right)^2$$

- VP** - differential pressure at sensor, inches w.g.
Q - air flow rate, cfm at standard density.
K - calibration constant

Unit Size	K
4	340
5	426
6	468
7	673
8	890
9	1155
10	1487
12	2141
14	3045
16	4074
24 x 16	7785

Notes

- Gauge taps are normally supplied with the pneumatic controls to allow field measurement of the differential pressure at the sensor with a manometer, magnahelic or other measuring device.
 If the terminal velocity controls utilize a flow-through transducer, a proper velocity pressure reading will NOT be read at the gauge taps and the calibration curves CANNOT be used for field measurement. The flow-through transducer operates on the principle of mass flow rather than pressure differential.
 Controls utilizing a dead-ended pressure transducer will allow field measurement with the gauge taps and calibration curves provided.
- Setting flow limits for a differential pressure of less than 0.02 inches is NOT recommended. Stability and accuracy of flow limits may not be acceptable due to low velocity pressure signal. Performance will vary depending on the terminal unit controls provided.
- For field calibration of air flow limits refer to the control contractor's documentation.

SP 300 Removable Sensor Maintenance Instructions

1. Detach SP 300 Hi and Low signal tubing between sensor and controls at the tee connections as shown in Figure 1.
2. Undo latches holding sensor in unit and remove sensor as shown in Figure 2.
3. Clean sensor by blowing compressed air through both hi and low signal tubing.
4. Wipe off any foreign particles with a clean rag.
5. Reinstall sensor into unit ensuring that it is in the correct orientation and fasten latches to securely hold sensor in unit.

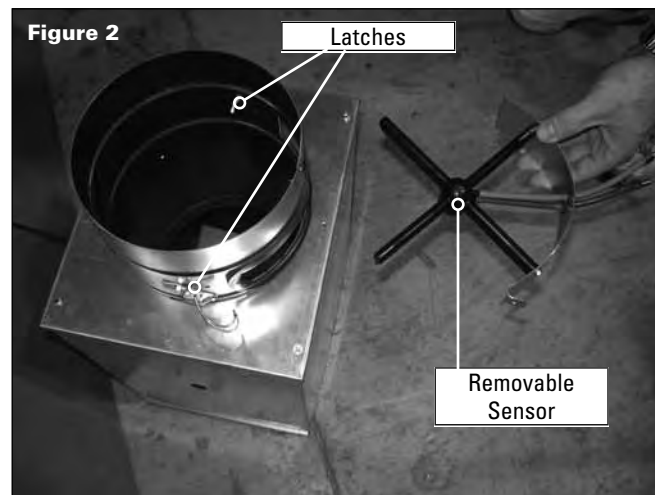
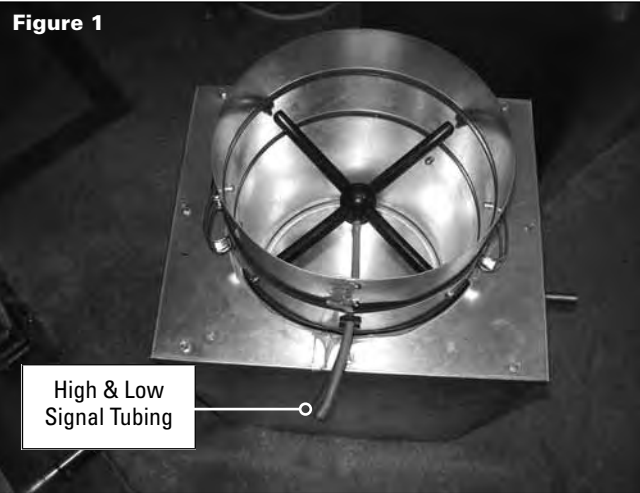

Replacement Parts

Component	Part#	Description
Removable SP300 Sensor	041688-001	Sensor SP300, Sizes 4,5 & 6
	041688-002	Sensor SP300, Size 7
	041688-003	Sensor SP300, Size 8
	041688-004	Sensor SP300, Size 9
	041688-005	Sensor SP300, Size 10
	041688-006	Sensor SP300, Size 12
	041688-007	Sensor SP300, Size 14
	041688-008	Sensor SP300, Size 16
	247072-001	Duct Cover, for Removable Sensor Sizes 4,5 &6
	247072-002	Duct Cover, for Removable Sensor Size 7
	247072-003	Duct Cover, for Removable Sensor Size 8
	247072-004	Duct Cover, for Removable Sensor Size 9
	247072-005	Duct Cover, for Removable Sensor Size 10
	247072-006	Duct Cover, for Removable Sensor Size 12
	247072-007	Duct Cover, for Removable Sensor Size 14
	247072-008	Duct Cover, for Removable Sensor Size 16
	203132-999	.250" Green Tubing, Low signal
	203136-999	.250" Red Tubing, High Signal
	041510-001	Rubber Grommet RB-215
	041683-001	Tee, Brass, .250" x .250" x .250"



PRICE
INDUSTRIES

2975 Shawnee Ridge Court
Suwanee, Georgia USA 30024
Ph: 770.623.8050 Fax: 770.623.6404



PRICE
INDUSTRIES

1290 Barrow Industrial Parkway
Auburn, Georgia USA 30011



PRICE
INDUSTRIES

999 North Thornton Road
Casa Grande, Arizona USA 85222-3809



e.h. price
LIMITED

638 Raleigh Street
Winnipeg, Manitoba Canada R2K 3Z9
Ph: 204.669.4220 Fax: 204.663.2715

The founding principles of our company have never changed - business integrity, first class service and a commitment to people. Price manufacturing endeavors arose from our belief that we could supply superior products and services at a reasonable price. Our mission is to become the world-wide supplier of preference for air distribution products and services. You can rely on Price – our products and services – with confidence.

Warranty: The Company warrants and guarantees that all goods within this catalog that have been manufactured by the Company have been manufactured in accordance with the specifications published herein and will be free from defects in material and workmanship for a period of twelve (12) months from the date of Bill of Lading issued by the Company. The Company will replace defective product at its option, but will not be responsible for labor or material charges in replacing product or consequential damages. Any installation not conforming with the Company's specifications, manuals, bulletins or instructions or any misuse or any modification not authorized by the Company voids this warranty. This warranty is in lieu of all Provincial, State, and Federal statutory warranties and the conditions herein are in substitution and replacement of such warranties, statutory or otherwise.

Your Local Price Representative:

Grilles & Diffusers

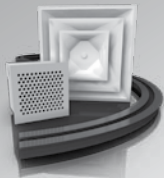

Critical Environments

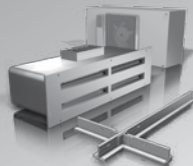

Terminals

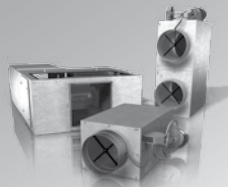

Sustainable Building

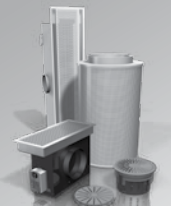

Noise Control

