



High Performance Fan Coils  
Genesis Model FCHG

**PRICE**<sup>®</sup>

[www.price-hvac.com](http://www.price-hvac.com)

# Introduction

Genesis High Performance Fan Coils feature high discharge static pressure and cooling capacities while meeting the low noise levels and high energy efficiencies required by today's HVAC market.

<b>Traditional Fan Coils</b>	<b>High Performance Fan Coils</b>
Flow range of 200-1200 cfm	Greater flow range of 100-2600 cfm
External pressures less than 0.3 in. w.g.	Higher external pressures up to 0.7 in. w.g.
Typically limited to small in-room heating/cooling applications	Higher cooling capacities for large spaces. Can use medium length duct runs to locate unit away from conditioned space.
Can be noisy due to multiple small diameter fans in each unit and no external attenuation	Fans selected for low noise levels. Optional enhanced attenuation.
Use low efficiency PSC motors	High efficiency ECMs
Low efficiency filtration	MERV 8 or 13 filtration available

**By using High Performance Fan Coils, you can reduce noise levels and energy consumption while receiving all the benefits of a standard fan coil system:**

- Individual room temperature control and zone shut-off.
- Energy efficient hydronic cooling and heating.
- Smaller air handling systems, which saves first cost and energy costs.
- Less building space required than with all-air central ventilation systems.
- Little or no cross contamination of recirculated air.
- Well suited for smaller projects and retrofits where space for mechanical equipment is limited.
- Capable of low-temperature heating applications such as those with solar or heat recovery refrigeration equipment.

# Applications

With the introduction of tough new energy requirements and the growth in popularity of high performance buildings, the opportunity exists for a premium quality fan coil unit that will meet the unique needs of these projects.

## LEED® Projects

Price Genesis Fan Coils can help contribute to LEED points in the following areas for new construction:

### **IEQc1 - Outdoor Air Delivery Monitoring**

The FCHGs Fresh Air Inlet option with SP300 sensor allows accurate monitoring of the outdoor air and the ability to control the outdoor air quantity. This option, coupled with a CO<sub>2</sub> sensor strategy, can be used to meet the requirements for this credit.

### **IEQc5 – Indoor Chemical and Pollutant Source Control**

The high static capability of the Genesis Fan Coils allows for the use of optional MERV 13 filters, which reduce airborne particles and meets the requirement for this USGBC LEED credit. The constant flow programming of the ECM also helps to maintain air flow rates and occupant comfort as the filters load.



### **EAc1 – Optimized Energy Performance: Design & Construction**

The Genesis Fan Coil's ECM does not directly earn any LEED credits, but it can be used to help reduce the overall energy consumption of the building and contribute to this credit.

## Expanded Applications

Price has designed Genesis Fan Coils with superior performance and features which expand their application beyond traditional fan coil units.

### **Some Applications include:**

- Commercial Spaces
- Hotels
- Educational Facilities
- Apartment Buildings
- Health Care Facilities

Price Genesis Fan Coils are the optimal choice for:

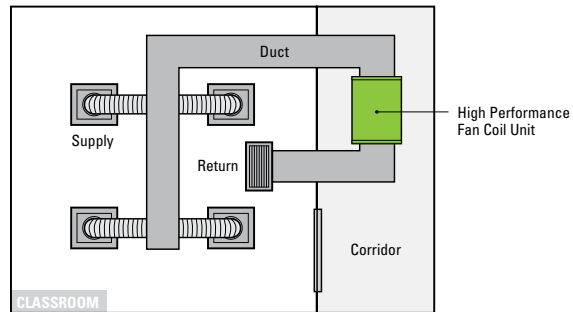
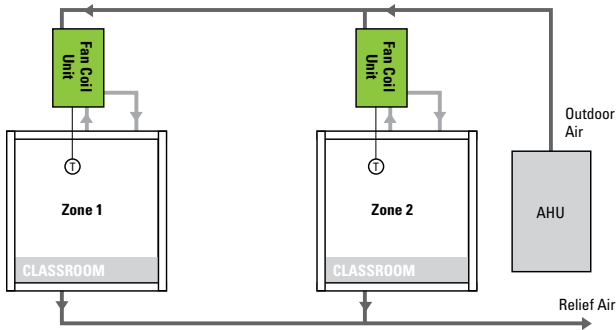

### Dedicated Outdoor Air Systems (DOAS)

Fan coils are ideal candidates for DOA systems. In this configuration a Central Air Handler is selected to dehumidify and condition the outdoor air as well as to handle the space latent load. A separate Fan Coil then provides sensible cooling or heating at the zone.

**This configuration has several advantages over a conventional VAV system:**

- Decoupling the sensible and latent loads ensures proper humidity control at each zone.
- Exact outdoor air requirements to each zone can be maintained, eliminating over-ventilation while ensuring compliance with ASHRAE 62.
- Energy savings can be realized due to reduced terminal reheat and reduced outdoor air requirements. The central system can be turned off during unoccupied hours with the fan coils maintaining local zone temperature control.

### Noise Sensitive Applications

The Genesis Fan Coil is inherently quiet due to its design and construction, making it the perfect choice for classrooms, lecture theaters, conference rooms, private offices, etc.

#### Features:

- The low turn-down of the ECM allows for unit selection at reduced speeds to meet low noise requirements.
- **To meet the most stringent acoustic specifications, tuned discharge and inlet silencers can be provided with Genesis Fan Coils for dramatic noise reductions.**



- Higher discharge static pressures accommodate accessories and longer duct runs.

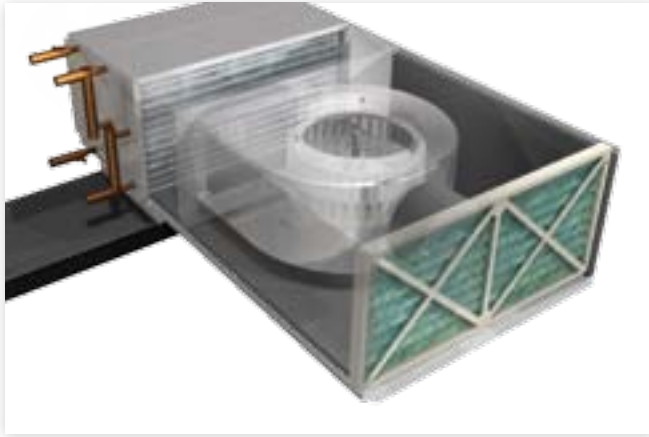

## Critical Environments & Health Care

The high static capability and cooling capacity of the Genesis Fan Coil unit extends its application to critical environment projects such as hospitals and laboratories.

### Features:

- Available with MERV 13 filters and a tight filter rack to meet the demanding filtration requirements for these projects.
- Available with stainless steel drain pans and coil casings, as well as a full range of liner options, from fiber free foam to double wall construction, to prevent bacterial growth.
- Available with up to 6 rows of cooling to handle high cooling load applications such as load driven labs.

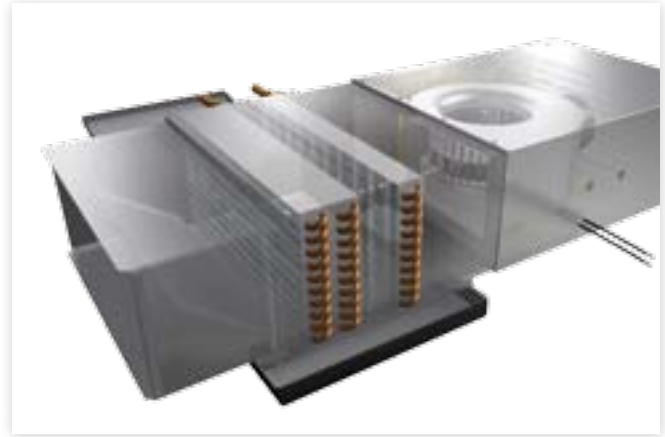

## Retrofit Applications

High performance fan coils can provide heating or cooling to previously unconditioned spaces or can add capacity to existing HVAC systems.

### Features:

- **Extremely well suited for building retrofits due to its low profile (maximum 15.5 in. height), which allows it to fit within a restricted ceiling plenum.**
- Since only outdoor air needs to be supplied to the space, supply ductwork is kept to a minimum.
- Features a modular construction which allows it to be shipped in sections for easy field assembly if required.

Should a retrofit have special requirements, the Price design team is capable of creating unique fan coil configurations to meet the needs of our clients.

**With the aid of 3D modeling software and extensive lab testing facilities, special designs or completely new models can be quickly prototyped and performance tested.**

Genesis Fan Coils complement new technologies and green concepts:

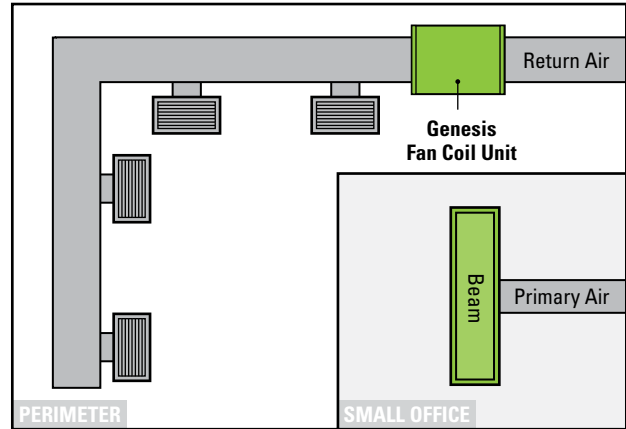
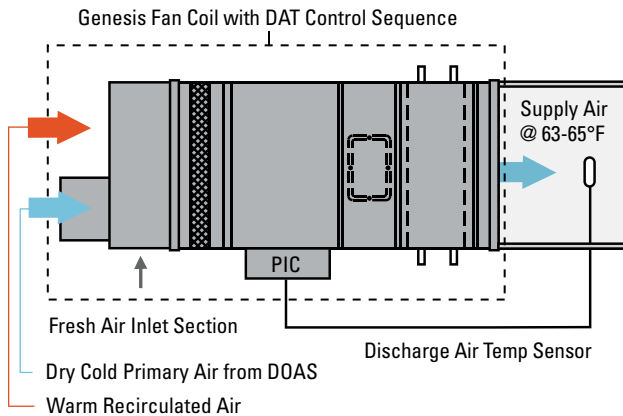

### Displacement Ventilation

Displacement ventilation is recognized as an effective method of air distribution for increasing Indoor Air Quality (IAQ) and occupant comfort.

One of the requirements for acceptable comfort is that the supply air temperature be maintained above 63 °F to prevent the sensation of draft at foot level. By utilizing a DOA system, low temperature dehumidified supply air can be delivered to a high performance fan coil to combine the outdoor air with warm recirculated room air to raise the overall temperature.

A Price PIC controller and discharge air temperature sensor regulates the cooling coil to maintain the discharge air temperature at an acceptable level for displacement ventilation. Quantity of supply air to the space is regulated with the variable speed ECM in accordance with the room load.

### Chilled Beam Projects

Active chilled beams offer the benefits of hydronic cooling without the requirement for a terminal fan or condensate removal system. However, the cooling capacity of active chilled beams is limited due to the higher chilled water temperatures required to avoid condensation and the restricted size of the cooling coil.

To enhance cooling capacity some beam manufacturers promote increasing the primary air flow beyond minimum ventilation requirements, which reduces the overall energy efficiency of the system. In those instances, Genesis coils are an attractive alternative to beams. With up to 6 rows of cooling coils available, **the FCHG is ideal for complementing beams in high load areas such as labs, perimeter zones with large glass areas and spaces with high equipment density.**

Note that both active chilled beams and high performance fan coils utilize the same hydronic system architecture, which keeps initial installation costs to a minimum.

# Product Features

Price offers a variety of features and accessories that make our Genesis Fan Coils unique:



## **Electronically Commutated Motors (ECM)**

- Energy efficient VAV operation.
- Factory set constant air flow programming.
- Compensates for filter loading.
- Reduced noise levels.
- Extended motor life and lower cooling load due to low operating temperature.



## **Noise Control Solutions**

- The blower/motor assemblies in the Genesis Fan Coils are completely isolated from the casing with vibration mounts to reduce generated noise and transmitted vibration.
- Large diameter, dynamically balanced blower wheels running at reduced RPM keep fan noise to a minimum.
- Cataloged octave band sound power levels for both discharge and radiated sound.
- Specially designed silencers are available on Genesis Fan Coils to dramatically reduce discharge and radiated noise levels.



## **Smaller Footprint**

- Low profile units and the reduced supply air volume of a hydronic system minimize ductwork requirements, resulting in reduced plenum heights.
- Our units can be installed in tight spaces.
- Lower construction costs and higher ceilings are possible.



**Serviceability**

- Genesis Fan Coils have bottom access panels to facilitate easier, faster maintenance on the motors and blowers.

**Innovative Accessories for Improved Indoor Air Quality**

- Liner options such as solid metal (dual wall), fiber free and foil face
- **Fresh air inlet option for accurate control and monitoring of outside air**
- MERV 13 filter option
- Stainless steel drain pan with secondary drain connection

**Lower Installed Costs**

- **Factory mounted and calibrated controls**
- **Piping packages sized and tagged for specific units**
- Single point power connections



# FCHG Series Dimensional Data

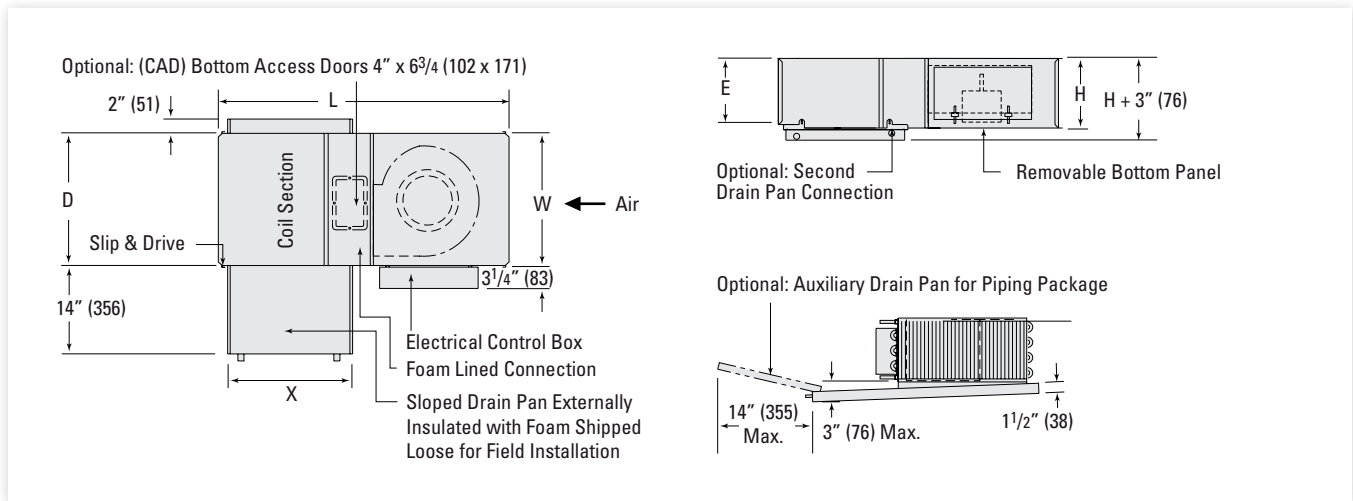

**Dimensional Data - IP (in.) / SI [mm]**

Unit Size	Max. Fan Flow, cfm	Outlet Duct Size		W	H
		D	E		
30	800 [377]	21 [533]	9 [229]	21 [533]	10 1/2 [267]
40	950 [448]	26 [660]	11 1/2 [292]	26 [660]	12 1/2 [318]
50	1550 [731]	42 [1067]	9 [229]	42 [1067]	10 1/2 [267]
60	2050 [968]	48 [1219]	11 1/2 [292]	48 [1219]	12 1/2 [318]
70	2800 [1324]	60 [1524]	11 1/2 [292]	60 [1524]	12 1/2 [318]

Connection Size	Number of Rows		
	1 & 2	3 & 5	6
30 - 60	7/8 [22]	7/8 [22]	1 1/8 [29]
70	7/8 [22]	1 1/8 [29]	1 1/8 [29]



## Coil Configurations

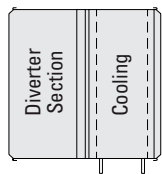

2 Pipe Cooling

- Cooling
- 1
  - 2
  - 3
  - 4
  - 6

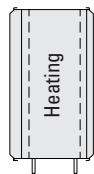

2 Pipe Heating

- Heating
- 1
  - 2
  - 3
  - 4
  - 6

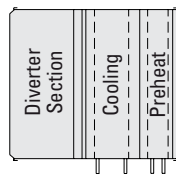

4 Pipe Preheat

- Preheat
- 1-3
  - 2-3
  - 1-4
  - 2-4
  - 1-6
  - 2-6

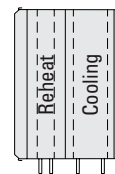

4 Pipe Reheat

- Reheat
- 3-1
  - 3-2
  - 4-1
  - 4-2
  - 6-1
  - 6-2

**Dimensional Data - IP (in.) / SI [mm]**

		Number of Rows									
		Cooling			Heating			Preheat		Reheat	
		1 & 2	3 & 5	6	1 & 2	3 & 5	6	1-3, 2-3, 1-4, 2-4	1-6, 2-6	1-3, 2-3, 1-4, 2-4	3 & 5
L	30 - 40	41 5/8 [1057]	43 1/8 [1095]	45 1/8 [1146]	33 5/8 [854]	35 3/8 [899]	37 3/8 [949]	48 3/8 [1229]	50 3/8 [1280]	40 3/8 [1940]	42 3/8 [1076]
	50 - 60	44 1/8 [1121]	45 7/8 [1165]	47 7/8 [1216]	36 1/8 [918]	37 1/8 [962]	39 7/8 [1013]	50 7/8 [1292]	52 7/8 [1343]	42 7/8 [2003]	44 7/8 [1140]
	70	47 7/8 [1197]	48 7/8 [1241]	50 7/8 [1292]	39 7/8 [994]	40 7/8 [1038]	42 7/8 [1089]	53 7/8 [1368]	55 7/8 [1419]	45 7/8 [2079]	47 7/8 [1216]
X		14 1/8 [359]			n/a (no drain pan)			17 7/8 [452]		17 7/8 [452]	

# FCHG Series Accessories

**Filter Rack Section**

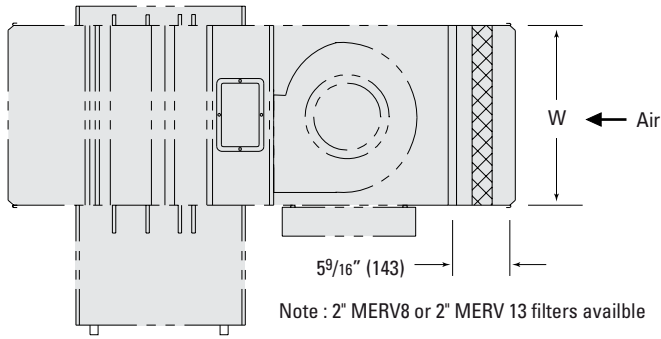

**Inlet Silencer**

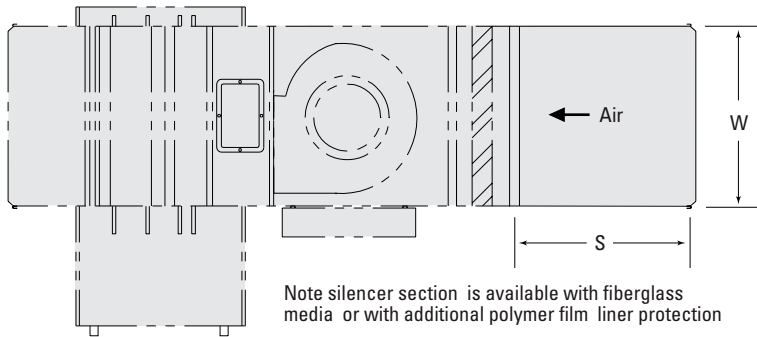

**Inlet Silencer**

Size	S, in	S, mm
30	18"	457
40	18"	457
50	18"	457
60	18"	457
70	36"	914

**Primary / Fresh Air Inlet**

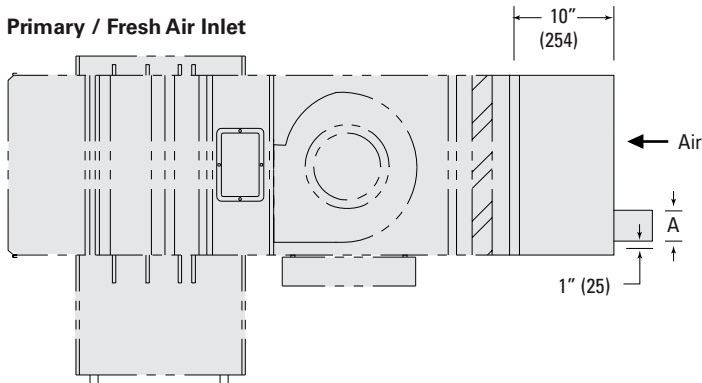

**Primary/Fresh Air Inlet**

Size	A, Diameter
30	6, 8 [152, 203]
40	6, 8 [152, 203]
50	6, 8 [152, 203]
60	6, 8, 10 [152, 203, 254]
70	6, 8, 10 [152, 203, 254]

# FCHGQ Series Dimensional Data

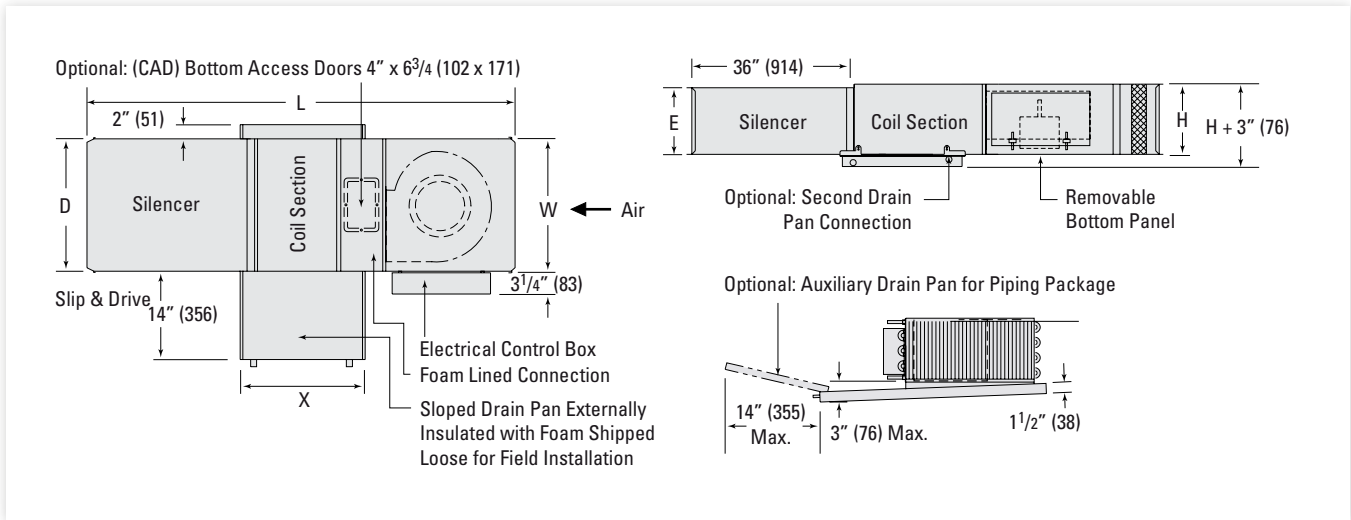

Dimensional Data - IP (in.) / SI [mm]

Unit Size	Max. Fan Flow, cfm	Outlet Duct Size		W	H
		D	E		
30	760 [358]	21 [533]	9 [229]	21 [533]	10 <sup>1</sup> / <sub>2</sub> [267]
40	910 [430]	26 [660]	11 <sup>1</sup> / <sub>2</sub> [292]	26 [660]	12 <sup>1</sup> / <sub>2</sub> [318]
50	1480 [698]	42 [1067]	9 [229]	42 [1067]	10 <sup>1</sup> / <sub>2</sub> [267]
60	1950 [920]	48 [1219]	11 <sup>1</sup> / <sub>2</sub> [292]	48 [1219]	12 <sup>1</sup> / <sub>2</sub> [318]
70	2700 [1274]	60 [1524]	11 <sup>1</sup> / <sub>2</sub> [292]	60 [1524]	12 <sup>1</sup> / <sub>2</sub> [318]

Connection Size	Number of Rows		
	1 & 2	3 & 5	6
30 - 60	7/8 [22]	7/8 [22]	1 <sup>1</sup> / <sub>8</sub> [29]
70	7/8 [22]	1 <sup>1</sup> / <sub>8</sub> [29]	1 <sup>1</sup> / <sub>8</sub> [29]



## Coil Configurations

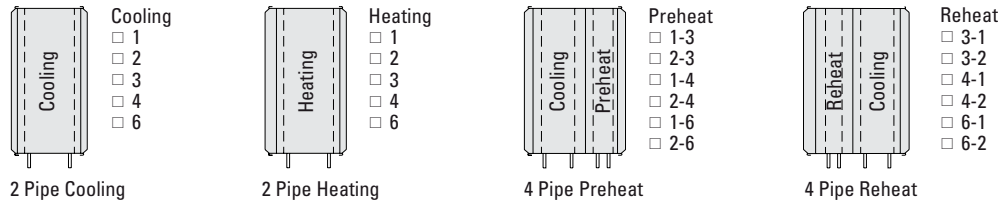

Dimensional Data  
IP (in.) / SI [mm]

		Number of Rows									
		Cooling			Heating			Preheat		Reheat	
		1 & 2	3 & 4	6	1 & 2	3 & 4	6	1-3, 3-1, 4-2, 2-4	1-6, 2-6	1-3, 3-1, 1-4, 2-4	1-6, 2-6
L	30 - 40	69 <sup>5</sup> / <sub>8</sub> [1971]	71 <sup>3</sup> / <sub>8</sub> [2009]	73 <sup>3</sup> / <sub>8</sub> [2060]	69 <sup>5</sup> / <sub>8</sub> [1768]	71 <sup>3</sup> / <sub>8</sub> [1813]	73 <sup>3</sup> / <sub>8</sub> [2060]	76 <sup>3</sup> / <sub>8</sub> [2143]	78 <sup>3</sup> / <sub>8</sub> [2194]	76 <sup>3</sup> / <sub>8</sub> [1940]	78 <sup>3</sup> / <sub>8</sub> [1990]
	50 - 60	72 <sup>1</sup> / <sub>8</sub> [2035]	73 <sup>7</sup> / <sub>8</sub> [2079]	75 <sup>1</sup> / <sub>8</sub> [2130]	72 <sup>1</sup> / <sub>8</sub> [1832]	73 <sup>7</sup> / <sub>8</sub> [1876]	75 <sup>1</sup> / <sub>8</sub> [2060]	78 <sup>7</sup> / <sub>8</sub> [2282]	80 <sup>7</sup> / <sub>8</sub> [2257]	78 <sup>7</sup> / <sub>8</sub> [2003]	80 <sup>7</sup> / <sub>8</sub> [2054]
	70	75 <sup>1</sup> / <sub>8</sub> [2111]	76 <sup>1</sup> / <sub>8</sub> [2155]	78 <sup>1</sup> / <sub>8</sub> [2206]	75 <sup>1</sup> / <sub>8</sub> [1908]	76 <sup>1</sup> / <sub>8</sub> [1952]	78 <sup>1</sup> / <sub>8</sub> [2060]	81 <sup>1</sup> / <sub>8</sub> [2282]	83 <sup>1</sup> / <sub>8</sub> [2333]	81 <sup>1</sup> / <sub>8</sub> [2079]	83 <sup>1</sup> / <sub>8</sub> [2130]
X		14 <sup>1</sup> / <sub>8</sub> [359]			n/a (no drain pan)			17 <sup>7</sup> / <sub>8</sub> [452]		17 <sup>7</sup> / <sub>8</sub> [452]	

# FCHG Series Accessories

### Filter Rack Section

Note : 2" MERV8 or 2" MERV 13 filters available

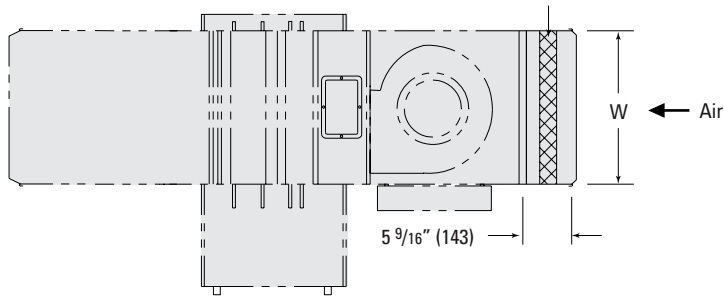

### Inlet Silencer

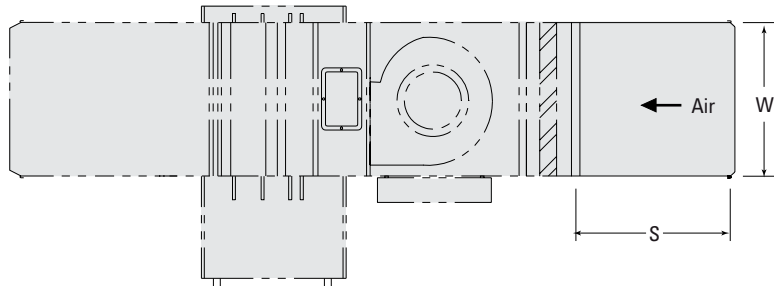

### Inlet Silencer

Size	S, in	S, mm
30	18"	457
40	18"	457
50	18"	457
60	18"	457
70	36"	914

### Primary / Fresh Air Inlet

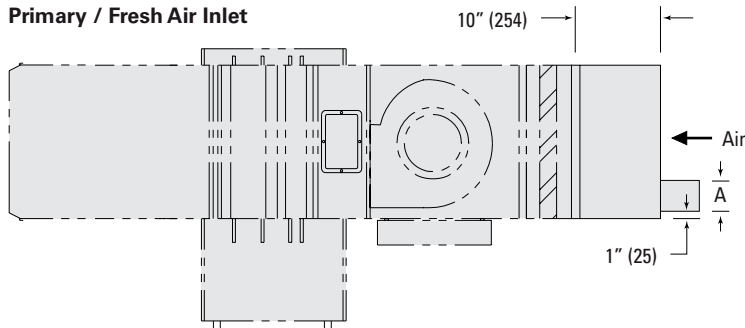

### Primary/Fresh Air Inlet

Size	A, Diameter
30	6, 8 [152, 203]
40	6, 8 [152, 203]
50	6, 8 [152, 203]
60	6, 8, 10 [152, 203, 254]
70	6, 8, 10 [152, 203, 254]

# FCHG/FCHGQ Performance Data

## Selection Guide

Size	Nominal CFM	4 Row Cooling				NC			
		GPM	QT	QS	WPD	Radiated		Discharge	
						Basic*	Silencer**	FCHG	FCHGQ
30	600	5	15.6	12	0.8	40	35	28	22
40	800	5	23.1	17.3	1.7	38	34	25	15
50	1200	6	32.2	25.1	2.6	43	36	30	17
60	1600	7	43.9	34.2	4.7	42	37	28	19
70	2200	10	59.5	46.4	12	45	41	32	27

\* Basic FCHG and FCHGQ \*\* FCHG and FCHGQ with inlet silencer

Size	Nominal CFM	2 Row Heating		
		GPM	Q	WPD
30	600	3	30.3	1.9
40	800	4	43.4	4.9
50	1200	6	61.2	3.3
60	1600	7	82.3	3.7
70	2200	8	107.7	3.5

Size	Fan Volume range., cfm	
	FCHG	FCHGQ
30	300-800	300-750
40	500-950	500-900
50	800-1500	800-1500
60	1200-2050	1100-1950
70	1500-2800	1500-2700

### Performance Notes:

- Cooling capacity based on 80 deg F dry bulb/ 67 deg F wet bulb entering air temperature and 45 deg F entering water temp
- QT is total cooling capacity in MBH, Qs is sensible cooling capacity in MBH
- Heating capacity based on 70 deg F entering air temperature and 180 deg F entering water temp
- Q is heating capacity in MBH
- GPM – gallons per minute
- WPD – water pressure drop in feet of water.
- Fan external static pressure is 0.25 in. w.g. [63 Pa] in all cases.
- NC values are calculated based on typical attenuation values outlined in Appendix E, 2002 Addendum to AHRI Standard 885-2008, "A Procedure for Estimating Occupied Space Sound Levels in the Application of air Terminals and Air Outlets".
- Radiated NC is based on a mineral fiber tile ceiling and the environmental effect. The radiated attenuation deductions are as follows:

Radiated Attenuation	Octave Band			
	2	3	4	5
<b>Total Deductions</b>	18	19	20	26

- Blanks (--) indicate NCs less than 20.
- Discharge NC is based on the environmental effect, duct lining effect, end reflection, flex duct effect and sound power division. The total discharge attenuation deductions are as follows:

Discharge Attenuation	Octave Band			
	2	3	4	5
<b>&lt;300</b>	24	28	39	53
<b>300-700 cfm</b>	27	29	40	53
<b>&gt;700 cfm</b>	29	30	41	52

# Controls

Price offers controls for fan coils that are easy to use. Both basic and deluxe control options are available to support standalone and networkable solutions.

## Price Controlling Thermostat

**With the PCT-D Price Controlling Thermostat, simple and economic standalone control is provided.** A fully digital and programmable thermostat, the PCT-D offers 2-pipe and 4-pipe solutions, along with a temperature probe for heat-cool changeover or for maintaining constant discharge air temperature (DAT).

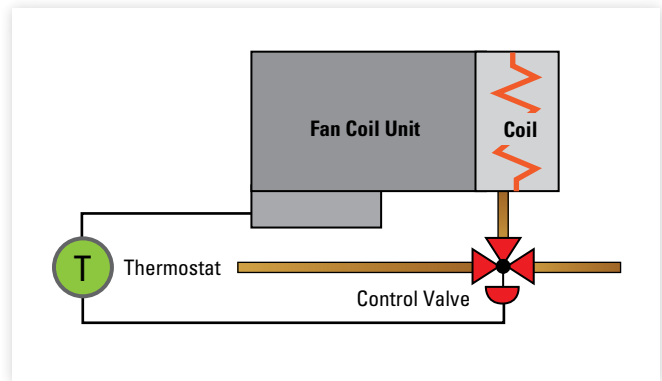

## Linker Device and Service Tool

**The PCT-D comes pre-calibrated from the factory; however, if field adjustments are required, the Linker device gives the end user this capability.** Connecting to the service port of the PCT-D thermostat, with the aid of a laptop, the free Linker Software from Price’s website allows you to view the menus and change parameters within the PCT-D fan coil controller.



## Flexible Control Options

The PIC-FC has 5 thermostat options to fit the building’s decor and architectural requirements— all with a different range of functionality.

- Blank Face Thermostat
- Dial Thermostat
- LCD Thermostat
- Motion Thermostat
- Wireless Thermostat





## Price Intelligent Controller for Fan Coils (PIC-FC)

**The PIC-FC controller is the ultimate solution for controlling 2-pipe and 4-pipe systems with full variable speed or constant speed motor options.** With a variety of control sequences available, the PIC-FC uses advanced and configurable proportional integral (PI) control, which results in exceptional user comfort and energy efficiency within a system. Another added feature is a temperature probe that can be used for heat-cool changeover or for maintaining constant discharge air temperature (DAT).

**The PIC-FC architecture has a modular design, which allows for the BACnet expansion module to be added when connection to a central BAS system is required.** The PIC-BAC expansion module can be factory installed, or connected in the field via the ribbon cable.

## Features and Benefits

The Price Fan Coil controls are designed and manufactured in-house at Price, which brings many benefits when ordering a high performance fan coil unit with Price controls.

- Controllers are programmed in-house – no delay on lead times.
- Factory programmed with required sequence and ready to go!
- Easy RJ-45 connections to the thermostat and the BACnet expansion module (PIC-FC only).
- Pluggable terminals for inputs, outputs and 24VAC power.
- Design engineering and application support available for troubleshooting.
- Easy field adjustments with LCD thermostat features & benefits



*PIC Plug 'N' Play*



## Noise Control Capability

One of the biggest concerns with traditional fan coil units has been noise generation. Price is unique among fan coil manufacturers in that we have our own in-house noise control group to provide acoustic expertise in the design of standard and special product models.

The Genesis Fan Coil unit has been sound tested in accordance with the industry recognized standards ASHRAE 130 and AHRI 880. Sound power levels for both discharge and radiated noise allow for accurate and reliable assessment of space sound levels.

Experience with silencer research and development has aided Price in developing acoustically effective close coupled inlet and discharge silencer solutions without compromising fan efficiency.

**Our Price noise control experts are available to assist on any acoustically sensitive fan coil application, providing selection assistance, system sound analysis, and when required, custom product solutions.**

## PRCN and Atlanta Lab Mock-Ups

Price Research Center North and the Atlanta Lab both feature test and measurement capabilities to validate both standard and special design fan coil units. **Flow measurement, energy consumption and controls sequence verification can be conducted in either facility.**

The PRCN has two reverberant sound chambers available for accurate sound measurement of both radiated and discharge noise. This is extremely valuable in dispelling acoustic concerns for engineers and other decision makers when evaluating close coupled silencers or other non-standard configurations.

The Atlanta acoustic mock-up room (IN-SITU room) is ideally suited to determine space sound levels with a fan coil unit installed and operating per the project specifications. Various construction, selection and acoustic treatments can be evaluated to ensure design goals are met.

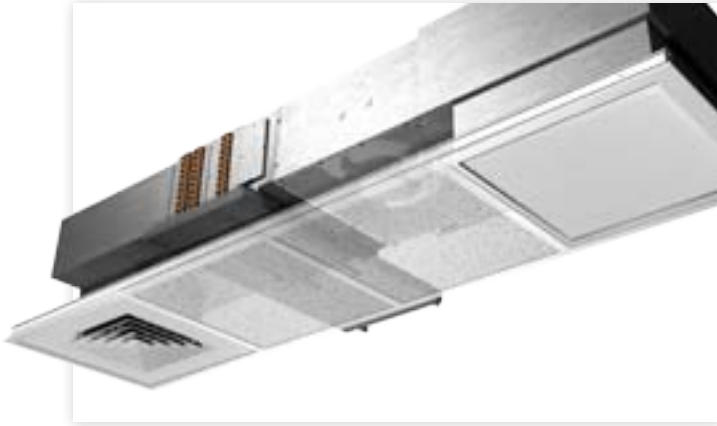

## Custom or Specials Capability

The Price Design team is capable of creating unique fan coil configurations in response to the specific needs of our clients. With the aid of 3D modeling software, in-house controls development and manufacture, plus extensive Lab testing facilities, special designs or complete new models can be quickly prototyped and performance tested.

## Product Application Support

Price has a long history of providing accurate and reliable product selection assistance to ensure space acoustic and comfort criteria are met. Regardless of whether the application is a classroom, private office, lab or health care space, Price can select and supply the correct combination of products.

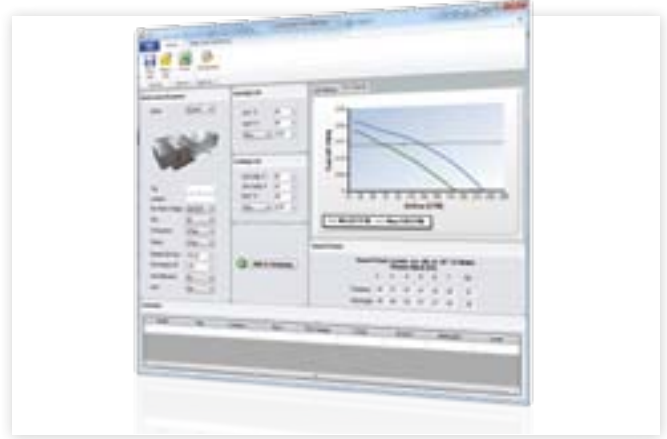

## Software Tools

Price's Fan Coil selection software allows you to easily calculate product performance and create schedules with speed and accuracy.

**Price Fan Coil Calc has many advantages over other fan coil selection programs currently available:**

- Auto Select Engine allows engineers to specify the most critical performance criteria and let the program select the most economical unit to meet their requirements.
- Generates dynamic sound power levels and AHRI 885 NC levels.
- Accounts for any additional accessories such as inlet or discharge silencers and liner options.

# Price Engineer's HVAC Handbook

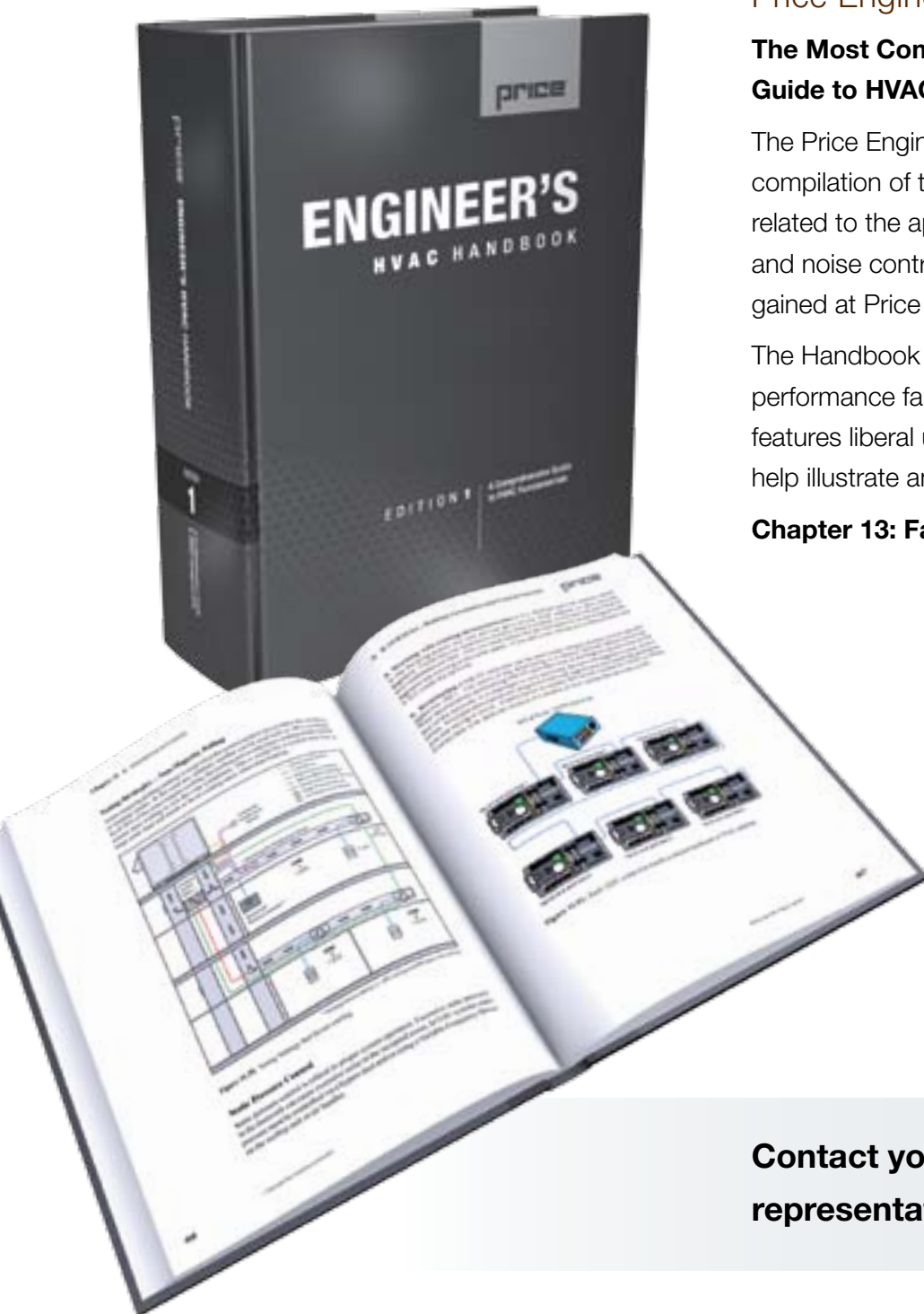

Price Engineer's HVAC Handbook

## **The Most Comprehensive Guide to HVAC Fundamentals**

The Price Engineer's HVAC Handbook is a compilation of the engineering knowledge related to the application of air distribution and noise control products and approaches gained at Price over the past 60 years.

The Handbook contains chapters on high performance fan coils and their applications, and features liberal use of examples and graphics to help illustrate and explain concepts and systems.

### **Chapter 13: Fan and Blower Coils**

**Contact your local Price sales  
representative to reserve your copy.**

# Product List

## Horizontal Fan Coils

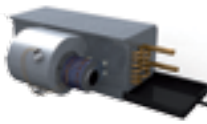

**FCHCB**  
Concealed Basic



**FCHCP**  
Concealed Plenum



**FCHE**  
Exposed



**FCHG**  
Genesis



**FCHGQ**  
Genesis Quiet

## Blower Coils



**BCH**  
Horizontal

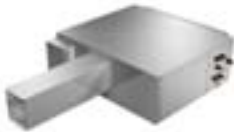

**BCHQ**  
Horizontal Quiet



**BCV**  
Vertical Blower Coil



**BCVQ**  
Vertical Quiet  
Blower Coil



**Blower Coils**  
with Electric Reheat

## Controls



**PIC-FC**  
Price Intelligent  
Controllers



**Linker2**  
Field Linker Device



**ECM**  
Standard or Deluxe  
Speed Controller



**SCR**  
Heater Controller

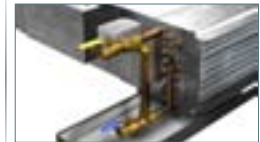

**Piping Packages**

## Fan Coil Accessories

## Thermostats



**Wireless**



**LCD with  
Motion Sensor**



**LCD**



**Dial**



**Room Sensor**



**CO2 and Humidity  
Sensing**

# PRICE®



2975 Shawnee Ridge Court  
Suwanee, Georgia USA 30024  
Ph: 770.623.8050 Fax: 770.623.6404

- U.S. Head Office
- Price Technical Center
- Atlanta Manufacturing Facility



1290 Barrow Industrial Parkway  
Winder, Georgia USA 30680-5704

- Atlanta Manufacturing Facility



999 North Thornton Road  
Casa Grande, Arizona USA 85222-3809

- Price Technical Center West
- Phoenix Manufacturing Facility



638 Raleigh Street  
Winnipeg, Manitoba Canada R2K 3Z9  
Ph: 204.669.4220 Fax: 204.663.2715

- Canadian Head Office
- Price Research Center North
- International Sales Office
- Winnipeg Manufacturing Facility



130B Pippin Road  
Vaughan, Ontario Canada L4K 4X9

- Toronto Manufacturing Facility

**Product Improvement** is a continuing endeavour at Price. Therefore, specifications are subject to change without notice. Consult your Price Sales Representative for current specifications or more detailed information. Not all products may be available in all geographic areas.

All goods described in this brochure are warranted as described in the Limited Warranty shown at the web site [www.price-hvac.com](http://www.price-hvac.com).

The Price catalog is available online at [www.price-hvac.com](http://www.price-hvac.com)

Grilles & Diffusers	Critical Environments	Terminals & Controls	Sustainable Building	Noise Control